



M AINTENANCE I NSTRUCTION

LOW LUBE OIL PRESSURE SWITCHES

8212824, 8259355, 8074612 AND 8084591

DESCRIPTION

For adequate engine lubrication and piston cooling it is essential that the oil supply is sufficient and that the pumps are operating properly. In the event that oil pressure falls below minimum requirements, some protective device is needed to cause alarms to function and/or to shut down the engine to protect it from possible damage.

Low oil pressure switches of the type shown in Fig. 1 are used to provide the desired protection. Similar protection is offered by the low oil pressure device that is an integral part of the electro-hydraulic and pneumatic-hydraulic governors used on engines for locomotives and drilling rig service.

To determine the scope of protection offered by these low oil pressure devices, it is suggested that the wiring diagram for the particular installation be checked for such circuit information.

OPERATION

A schematic operating diagram of low oil pressure switch 8212824, which is typical of these switches, is shown in Fig. 2.

The bellows stud (8) is screwed into the lever arm (4) so that the bellows portion just contacts the case and then is backed out about one turn. The range spring (7) counteracts the bellows and bellows spring upward pressure, and is adjusted to overcome their combined upward force at the low oil pressure setting of the switch. In the case of switch 8212824, this pressure is 17 psi. The

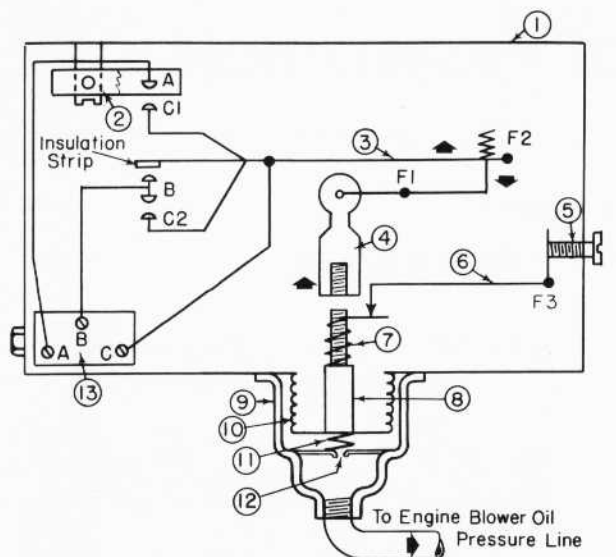

Fig. 1 - Low Oil Pressure Switch

downward force of the range spring, through lever arm (4) and fulcrums F1 and F2 cause the movable contact arm to move upward and close the contacts. When oil pressure exceeds the low oil pressure setting, this pressure plus the bellows spring pressure overcomes the range spring pressure, forcing the lever arm (4) upward. The movable arm is then moved downward and the contacts open.

The position of the permanent magnet (2) controls the differential or downward breaking point of the switch. The lower the magnet, the greater its influence, consequently, differential or difference between "make" and "break" of the contacts is lessened. Changing the "range" or operating point by screw adjustment (5) does not alter the differential unless a considerable change in range setting is made. The magnet also provides for quick "make" and "break" of the contacts and prevents excessive arcing.

* THIS BULLETIN IS COMPLETELY REVISED AND SUPERSEDES M. I. 1531.



- | | |
|--|--|
| 1. Case | 8. Bellows Stud |
| 2. Permanent Magnet And
Differential Adjustment | 9. Bellows Portion |
| 3. Movable Contact Arm | 10. Metallic Bellows |
| 4. Lever Arm | 11. Bellows Spring |
| 5. Range Adjustment Screw | 12. Orifice |
| 6. Lever | 13. Terminal Board |
| 7. Range Spring | Contacts - A, C1, B, C2
Fulcrums - 1, 2 & 3 |

Fig. 2 - Schematic Operating Diagram
Low Lube Oil Pressure Switch 8212824

MAINTENANCE

At intervals specified in the Scheduled Maintenance Program, Maintenance Instruction 1704, the low oil pressure protective device should be checked for proper operation and reset if necessary.

NOTE: The low oil pressure shutdown mechanism used in electro-hydraulic and pneumatic-hydraulic governors is designed to operate at preset pressures that are not adjustable. These devices, however, should be checked for proper operation. Refer to Section XI of the 567 Engine Maintenance Manual for details.

A suitable apparatus may be constructed to properly test the operation of the low oil pressure switch using air pressure. It should feature an accurate laboratory type gauge (with one pound increments), a mounting for the switch

being tested, and a shutoff valve. In addition, since air pressure will have to be controlled, a reducing valve to charge the system is required as is a needle valve for reducing the air pressure.

CHECKING AND SETTING LOW OIL PRESSURE SWITCHES

Referring to Fig. 3, the switch may be checked and adjusted as follows:

1. Mount switch to test apparatus in normal position with bellows portion downward.
2. Apply air pressure in excess of that necessary to close the normally closed contacts (movable contact arm in downward position).
3. Using the needle valve on the test apparatus, reduce the air pressure and observe the pressure at which the contact arm moves upward and closes the contacts. This should occur with a definite snap action at the pressure specified in the Maintenance Data Section. For example, this should be 17 psi for switch 8212824.

If adjustment is needed, turn the range adjusting screw clockwise to increase, or counterclockwise to reduce the pressure necessary to actuate the contact arm properly.

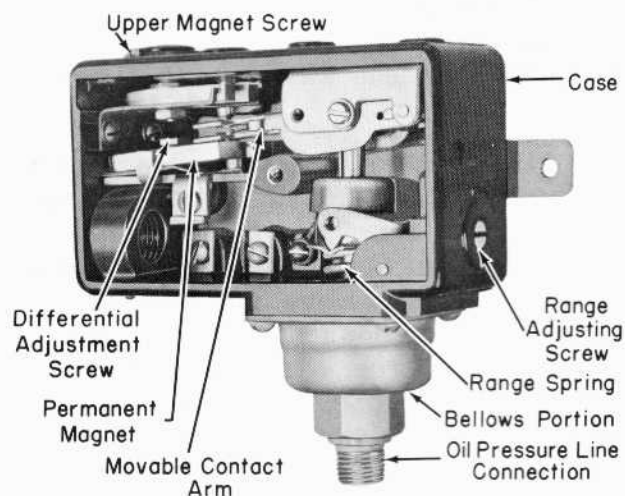

Fig. 3 - Low Oil Pressure Adjustment

4. After properly completing the preceding step, slowly raise the air pressure to check the point at which the contact arm moves downward. This should occur at the pressure specified in the Maintenance Data Section. For example, 22 psi for switch 8212824.

If adjustment is needed, the differential adjusting screw should be used. On switches of the type shown in Fig. 1, this is an Allen set screw. Switches similar to Fig. 3, use a hexagon head type screw.

NOTE: The upper magnet screw is sealed and should not be changed unless correct adjustments cannot be made as outlined above. If this should be necessary, reseal after adjustment.

5. Recheck switch operation and reset as necessary until settings correspond to those specified for the particular switch. Switches that cannot be properly adjusted should be replaced and returned for remanufacture. Consult your Factory Rebuild Service Bulletins for details.

MAINTENANCE DATA

Switch Part No.	Pressure Setting Of Movable Contact Arm		Contact Arrangement
	Up	Down	
*8259355	4 psi	7 psi	SP-DT
8212824	17 psi	22 psi	DP-ST
*8074612	3 psi	6 psi	SP-DT
*8084591	4 psi	7 psi	SP-DT

*Switch 8259355 has replaced switches 8074612 and 8084591. This new switch is preset for 4 and 7 psi and does not have to be changed when using it to replace switch 8074612.