



MAINTENANCE INSTRUCTION

AUXILIARY RELAYS -- 8, 12, AND 14 POLE

DESCRIPTION

The auxiliary relays, Fig. 1, covered in this instruction are of the same basic construction, and are used in a wide variety of applications. Differences occur primarily in number and contact arrangement.

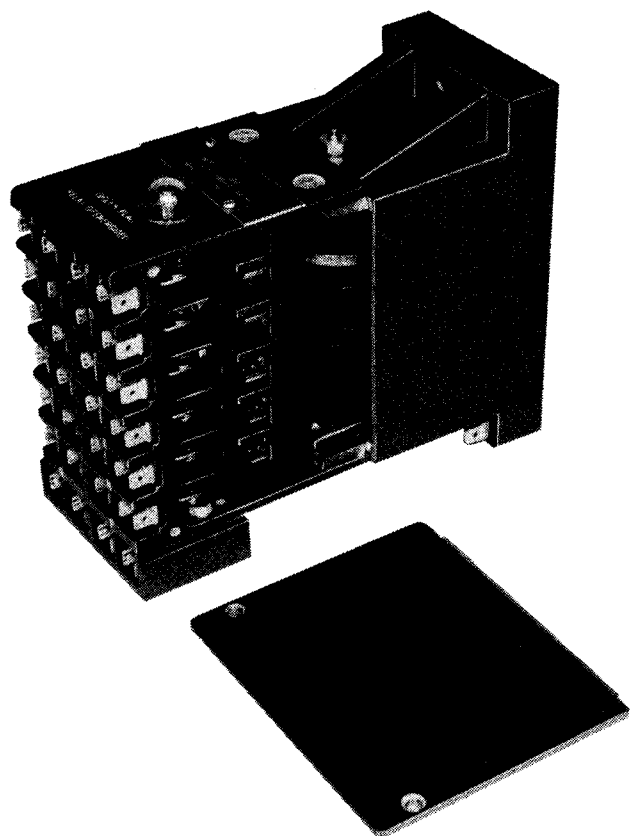

14823

Fig. 1 - Typical Auxiliary Relay

The coils of the 8 and 14 pole relays, and the majority of 12 pole relays, operate off 74 volt control circuits; the exceptions require 120 V DC. (See Service Data.) The contact arrangements are designed to set up a variety of control circuits for product operation. The individual wiring diagrams indicate relay function.

MAINTENANCE

Simplicity of construction with a minimum of moving parts, gold diffused contacts, and a dust free enclosure provides satisfactory service life. Therefore, maintenance consists primarily of periodic inspections to qualify relays for continued service.

INSPECTION

Remove the relay covers and check contacts for pitting or burning. Use a low pressure stream of dry, compressed air, and blow out any dust or dirt accumulation. If contacts are badly burned or pitted, remove and overhaul relay.

Do not file or dress relay contacts. Relay contacts will turn black (tarnish) in time with normal operation. This will not impair relay operation or indicate a need for servicing.

Inspect the electrical connections for tightness and electrical contact. Inspect the operating coil for burns or discoloration. Check coil resistance and relay pickup and dropout, using the values given in the Service Data.

Movable mechanical parts should be checked for proper operation. Do not apply lubrication of any type to these relays.

DISASSEMBLY, Fig. 2

Remove the four screws and lockwashers holding covers to the contact housing assembly. Remove two screws and lockwashers holding the contact housing assembly to coil frame and coil housing, and the two shorter flat head screws and lockwashers holding contact housing assembly to coil housing.

The contact housing assembly can now be removed by carefully lifting the housing up and away from the coil and frame housing, while at

*This bulletin is revised and supersedes previous issues of this number.

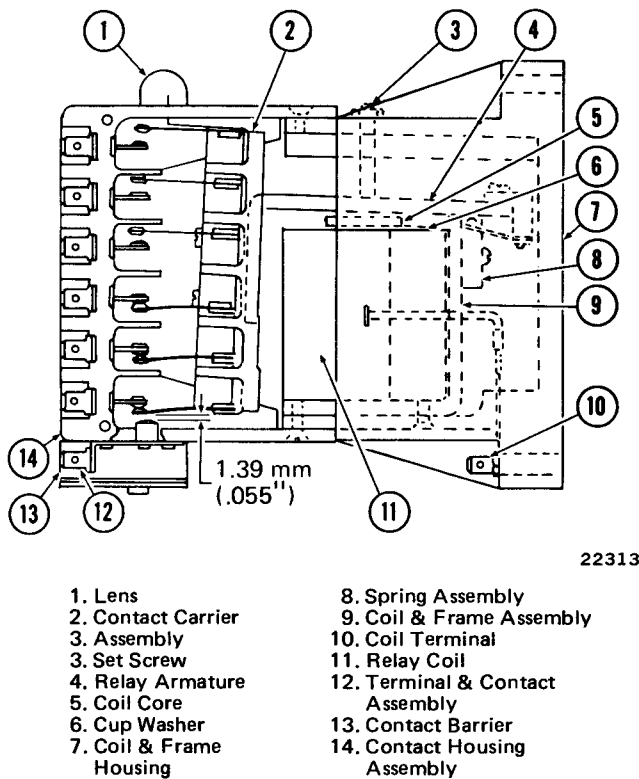

Fig. 2 - Cutaway View Of Relay

the same time holding the armature against the core. Be careful to ensure against damage to the indicating tab which protrudes into the lens while performing this operation.

NOTE: The information contained in this paragraph applies only to 14 pole relays. The four attached terminal and contact assemblies can be replaced by removing the cover which is held on by two screws and lockwashers, then each individual terminal and contact can be removed. The terminals and contacts are held in place by two screws.

To remove the coil and frame assembly from the coil housing, remove the two screws holding coil frame to coil housing. Hold the armature against the core, and lift the assembly out of the housing. Using a long nose pliers, disconnect the coil lead connectors from the terminals. Do not turn the adjusting screw unless it is being replaced.

To disassemble the relay coil, Fig. 3, remove the screw and lockwasher holding the coil, core and cup washers to the coil frame.

REASSEMBLY

To reassemble the relay, follow the reverse order of disassembly. Ensure all parts are cleaned thoroughly.

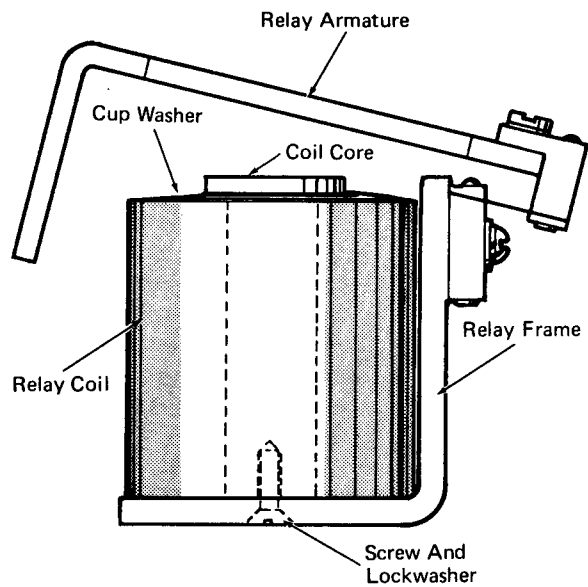

Fig. 3 - Coil And Frame Assembly

When a new coil is installed, ensure a 0.20 mm - 0.25 mm (.008" - .010") gap exists between the relay armature and the relay frame when armature is held against the coil core, Fig. 4. To set the gap, loosen the two round head screws holding the spring assembly, and reposition the assembly. Insert feeler gauge while holding the armature against the core, and tighten screws.

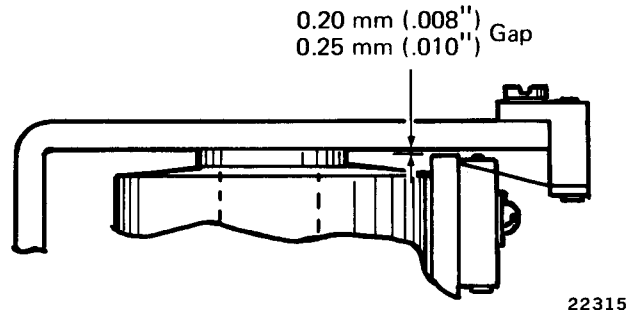

Fig. 4 - Armature Spacing With Relay Energized

Check the travel gap between the armature and core center with relay in a de-energized position. Adjust the set screw, if necessary, to obtain a minimum distance of 1.59 mm (.063"). After adjusting, ensure set screw remains in position when tightening the locknut. The armature should seat squarely against the core when relay is energized.

When replacing the contact housing assembly, do not bend the brush assemblies which protrude from the carrier assembly. Manually position the carrier assembly for proper placement of the contact housing to the relay housing, being careful not to bend or damage the indicator tab when placing it in the lens. It may be necessary to

position the tab with a long nose pliers after housing is secured. Ensure tab is flush with the housing when relay is energized.

CHECKING AND ADJUSTING RELAY CONTACT PRESSURE

Check the pressure required to open all normally closed contacts with a gram gauge (50 to 250 range). This check can be made by connecting the normally closed contacts in series with a simple low voltage (6 volt) lamp circuit. The reading should be taken at the position the lamp is de-energized. Place the probe of the gauge over the small hole located between each set of contacts on the contact brush assembly, Fig. 5. A minimum reading of 100 grams pressure and a maximum of 150 grams pressure is acceptable before contact opening.

Location of gauge probe for proper measurement of relay contact pressure.

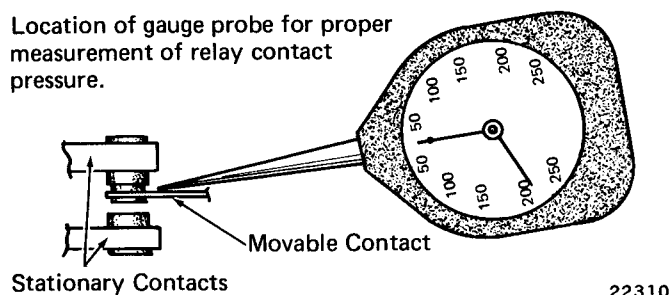

Fig. 5 - Location Of Gauge Probe

With a DC voltage of approximately 2 to 3 volts above the rated pick-up voltage, energize the relay coil. Check the pressure required to open all contacts which close when coil is energized. A minimum reading of 100 grams should be obtained on this test.

If the minimum reading of 100 grams is not obtained, the contact brush assembly will have to be adjusted. Using an adjusting tool, Fig. 6, make gradual adjustments along the length of the contact brush assembly.

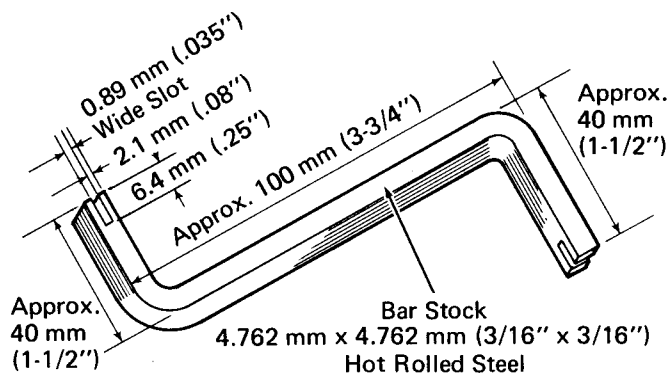

Fig. 6 - Typical Relay Adjusting Tool

Do not make any sharp creases or bends in the assembly. Since each brush assembly has two contacts, each contact should be checked to be sure they are on the same plane, and make contact with the stationary contacts at the same time. If they do not, twist the assembly very slightly with the adjusting tool, then readjust the assembly for proper pressure. After making any adjustments, recheck the contact pressure to be sure they are within the minimum or maximum pressure range.

All normally open contacts, when the relay is energized, should have a minimum of 2.38 mm (.094") air gap; 1.39 mm (.055") gap for contacts L, M, N, and P.

PICKUP AND DROPOUT VOLTAGE TEST

To perform pickup and dropout checks, connect a variable DC voltage supply to the relay coil as shown in Fig. 7. Set the 50 watt potentiometer to maximum resistance; gradually increase the voltage to the coil.

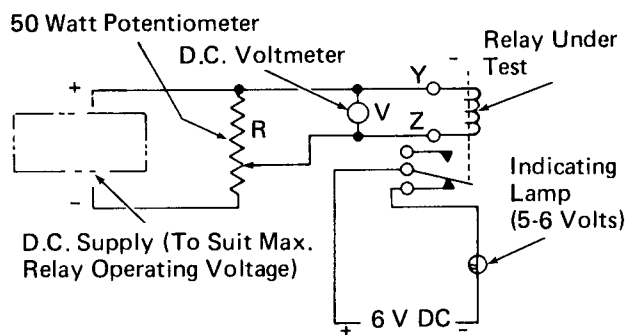

Fig. 7 - Suggested Test Setup

An indicating lamp (connected across the contacts) will mark the pickup or dropout points by coming on or going off. Slowly reduce the applied voltage to determine the dropout point.

If the pickup and dropout points are not obtained as outlined in the Service Data, check lead arrangement, contact pressure, and carrier travel gap. Readjust if necessary.

After adjustments have been completed, replace the side covers with two screws and lockwashers, and cycle the relay 25 to 50 times with a 5 to 5-1/2 volt, 1/2 ampere load (test lamp) connected across each set of contacts. Positive contact should be accomplished on each cycle, or the relay must be reworked.

SERVICE DATA

SPECIFICATIONS

8 POLE: 8367562, 8369154, 8383145

Contact Rating: 5 Ampere, 74 V DC, Resistive

Coil Data @ 20° C (68° F):

Working Voltage	74 V DC
Max. Pickup	48 V DC
Dropout	5-28 V DC
Ohms	373 ± 10%

12 POLE: 8357418, 8357419, 8361774, 8391256, 8421094

Contact Rating: 10 Ampere, 74 V DC, Resistive

Coil Data @ 20° C (68° F):

Working Voltage	74 V DC
Max. Pickup	48 V DC
Dropout	5-28 V DC
Ohms	373 ± 5%

8365353, 8370706, 8371879

Contact Rating: 5 Ampere, 120 V DC, Resistive

Coil Data @ 20° C (68° F):

Working Voltage	120 V DC
Max. Pickup	98 V DC
Dropout	10-56 V DC
Ohms	1390 ± 10%

14 POLE: 8363130, 8364908, 8364295, 8367084, 8394594

Contact Rating: 5 Ampere, 74 V DC, Resistive

Coil Data @ 20° C (68° F):

Working Voltage	74 V DC
Max. Pickup	48 V DC
Dropout	5-28 V DC
Ohms	373 ± 5%

HI-POT (60 Hz):

8 POLE: 8367562, 8369154, 8383145

Coil To Ground	600 V RMS
Coil To Contacts	2400 V RMS
Contacts To Ground	2400 V RMS
Contacts To Contacts	2400 V RMS

12 POLE: 8357418, 8357419, 8361774, 8391256, 8421094

Coil To Ground	1000 V RMS
Coil To Contacts	2400 V RMS
Contacts To Ground	2400 V RMS
Contacts To Contacts	2400 V RMS

8365353, 8370706, 8371879

Coil To Ground	1500 V RMS
Coil To Contacts	1500 V RMS
Contacts To Ground	1500 V RMS
Contacts To Contacts	1500 V RMS

14 POLE: 8363130, 8364295, 8367084, 8394594

Coil To Ground	600 V RMS
Coil To Contacts	600 V RMS
Contacts To Ground	2400 V RMS
Contacts To Contacts	2400 V RMS

8364908

Coil To Ground	600 V RMS
Coil To Contacts	2400 V RMS
Contacts To Ground	2400 V RMS
Contacts To Contacts	2400 V RMS

CONTACT TERMINALS

- 8 POLE:** 8367562 - 2 N.O. - 6 N.C.
- 8369154 - 5 N.O. - 3 N.C.
- 8383145 - 4 N.O. - 4 N.C.

- 12 POLE:** 8357418 - 6 N.O. - 6 N.C.
- 8357419 - 4 N.O. - 8 N.C.
- 8361774 - 8 N.O. - 4 N.C.
- 8391256 - 12 N.O.
- 8421094 - 10 N.O. - 2 N.C.
- 8365353 - 6 N.O. - 6 N.C.
- 8370706 - 8 N.O. - 4 N.C.
- 8371879 - 10 N.O. - 2 N.C.

- 14 POLE:** 8363130 - 8 N.O. - 6 N.C.
- 8364908 - 9 N.O. - 5 N.C.
- 8364295 - 10 N.O. - 4 N.C.
- 8367084 - 7 N.O. - 7 N.C.
- 8394594 - 6 N.O. - 8 N.C.

M.I. 5387

The following items are applicable to all above listed relays:

Contact Pressure	100 Grams Min. 150 Grams Max.
Contact Air Gap	2.38 mm (.094") Min.
Contacts L, M, N, and P Air Gap	1.39 mm (.055")
Core & Armature Travel Gap	1.59 mm (.063")