



SERVICE DEPARTMENT

ELECTRO-MOTIVE DIVISION • GENERAL MOTORS CORPORATION

MAINTENANCE INSTRUCTION

EMD STATIC VOLTAGE REGULATOR

INTRODUCTION

This publication provides complete instructions for bench testing and repairing EMD Static Voltage Regulators, Fig. 1. Also included are instructions for calibrating the voltage regulator to obtain desired output voltage of the auxiliary generator. Categorized defects, drawings, schematics, wiring diagrams, and repair procedures are included to aid the technician in troubleshooting and repairing the voltage regulator.

DESCRIPTION

This solid-state electronic assembly is designed to maintain output voltage of the auxiliary generator to within ± 1 volt of the "set point." Normally the regulator is adjusted for a nominal output voltage of 74 volts. This power is used to charge batteries and operate devices in the locomotive

control circuitry. The voltage regulator will maintain output to within ± 1 volt of the "set point" through a wide variation of ambient temperature, auxiliary generator rotating speeds, and loads. Some regulators also provide a stable 72 volt source which is used as a reference for the static excitation system.

The electronic components of the voltage regulator form four individual circuits; a starting circuit, a detector circuit, a power circuit, and an oscillator circuit, Fig. 2.

Upon start-up residual magnetism initially provides auxiliary generator excitation. Generator output at this time is not sufficient to cause a silicon controlled rectifier (SCR) to turn on. The starting circuit allows generator output to build up before allowing the SCR to start controlling regulation. The other three circuits work together

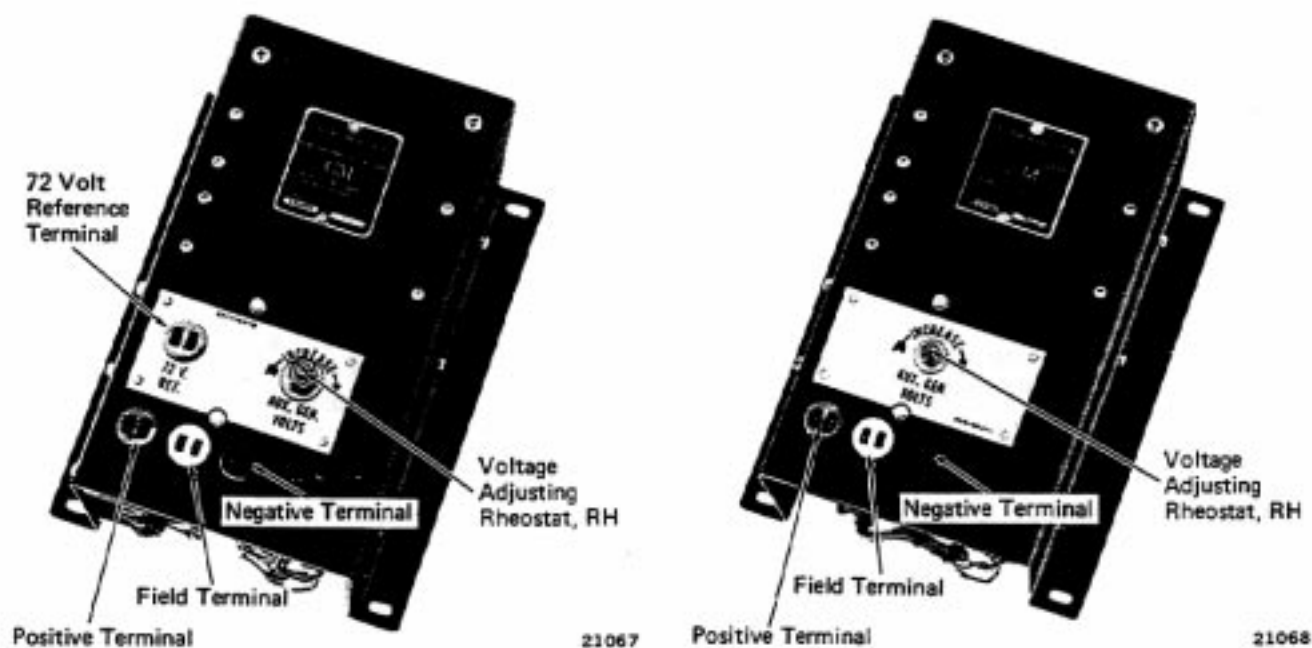

Fig. 1 - Static Voltage Regulators

*This bulletin is revised and supersedes previous issues of this number.

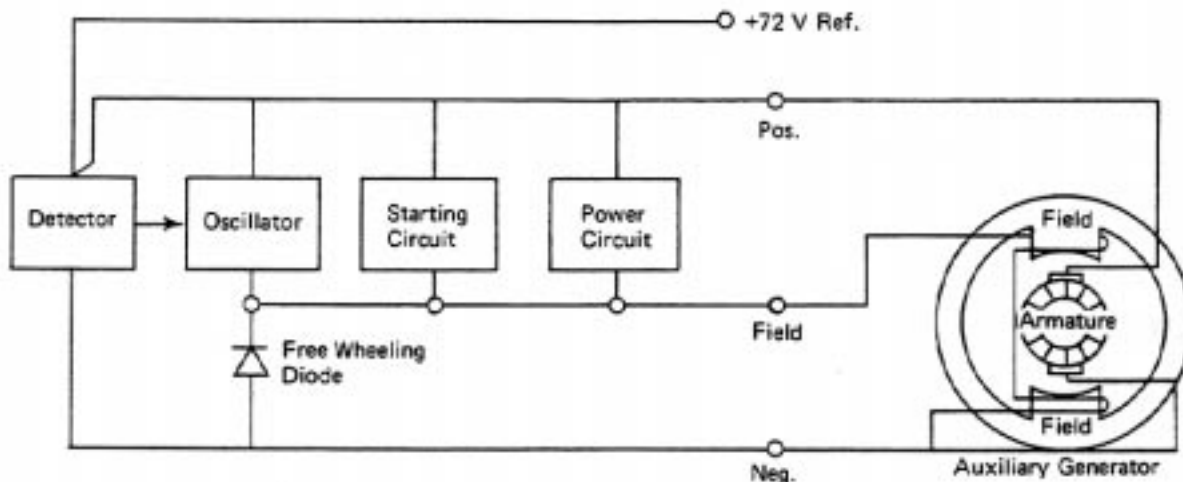

Fig. 2 - Regulator Circuit Block Diagram

21069

to regulate output voltage of the auxiliary generator by opening and closing the power circuit to the generator field. This is accomplished by controlling conduction of the SCR. This device acts as a switch which can be turned on by a gate signal from the detector circuit. Once turned on, the SCR will continue to conduct until a positive pulse is applied to its cathode. A positive pulse is applied to the cathode of the SCR during each cycle of oscillation by the oscillator circuit. If output voltage of generator is above the "set point" the SCR will remain off. If output is below "set point" the SCR will be turned on by the detector circuit as soon as the positive pulse from the oscillator circuit is removed. Positive pulses from the oscillator circuit occur often enough to prevent any noticeable difference in field strength between pulses. When the SCR is turned off, the generator field tends to collapse, however, current generated by the decaying field flows through a free-wheeling diode (D3) causing a gradual decay instead of a sudden collapse. The gradual decay of the field, frequency of oscillations from the oscillator, and response of the detector and power circuits result in a stable output from the auxiliary generator.

Physically the regulator is arranged in two parts: the cabinet and the circuit board. Large power carrying components are mounted to the cabinet. Smaller solid state devices which handle relatively small amounts of power are mounted on the circuit board.

FUNCTIONAL TESTS

This section when used in conjunction with the Troubleshooting And Repair section is intended as a guide for troubleshooting. To avoid possibility of injury to personnel or damage to equip-

ment, service personnel should have an understanding of the equipment and a cognizance of safety practices. Read entire procedure including all notes, cautions, and warnings before performing following steps.

1. Using a battery test light, connect positive lead to positive terminal P on front of voltage regulator and negative lead to field terminal F, Fig. 1. Refer to Service Data for test components.
2. The test light should come on, if not, replace starting relay and repeat Step 1. If the test light did come on proceed.

CAUTION: Make certain that test power supply is off before making any electrical connections to regulator. Observe polarity. If positive and negative leads are reversed, costly internal damage will result.

3. Connect regulator in the test circuit shown in Fig. 3. See Service Data for information concerning test components.
4. Turn voltage adjusting rheostat RH, Fig. 1, for minimum resistance (full travel counter-clockwise from front).
5. On regulators equipped with the 72 volt reference feature, attach a jumper wire, Fig. 4, across end terminals of reference voltage setting resistor R1.

CAUTION: Before proceeding make certain that variable voltage control on test power supply is at minimum setting.

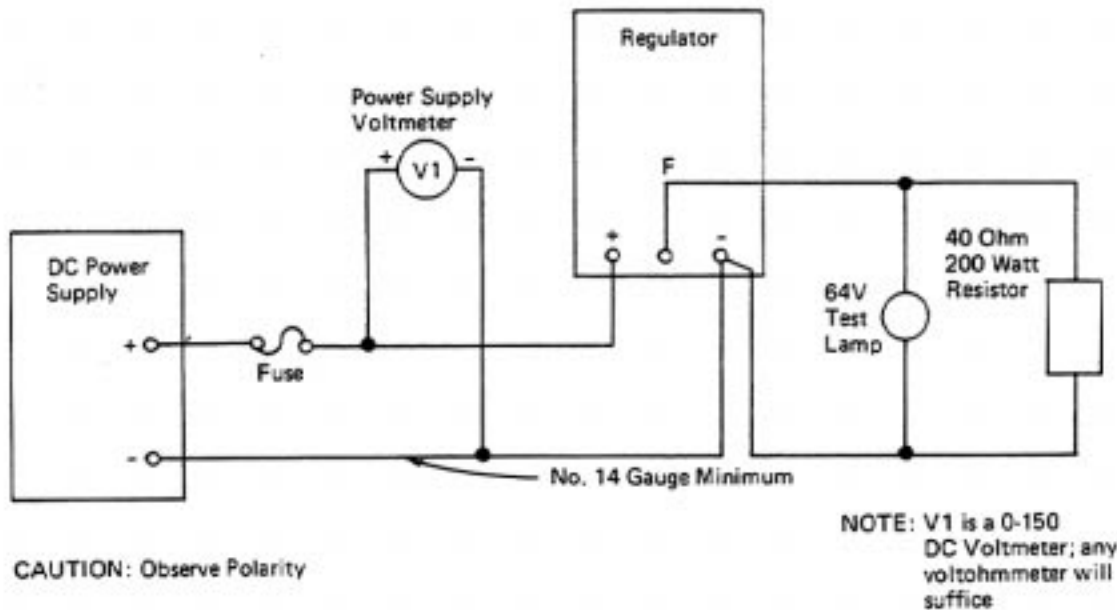

Fig. 3 - Regulator Test Circuit

21070

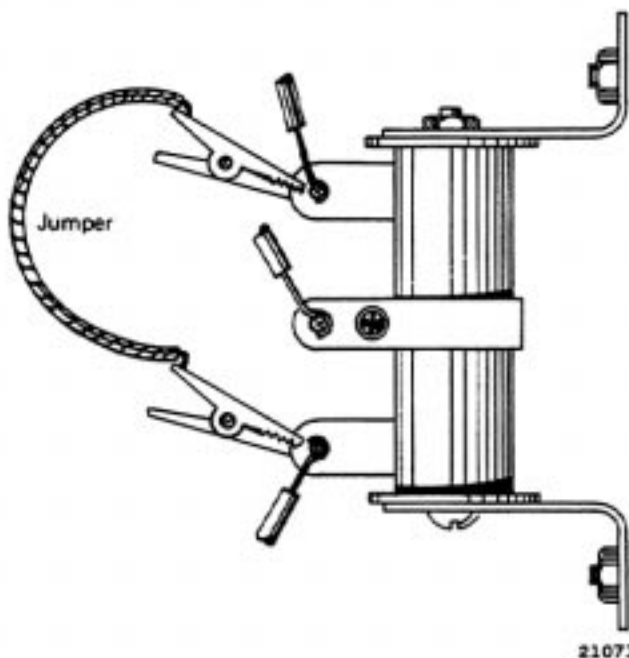

Fig. 4 - Shorting Reference Voltage Resistor

6. Turn power supply on. Slowly increase supply voltage to regulator. Observe both the power supply voltmeter and test lamp. Match voltmeter and test lamp indications with the corresponding indication in Fig. 5. Proceed to Step 7 only after regulator displays normal indication.
7. Turn voltage adjusting rheostat RH, on front of regulator, for maximum resistance (full travel clockwise from front).

NOTE: Remove jumper wire applied to reference voltage setting resistor R1, in Step 5 above.

8. On regulators equipped with 72 volt reference feature, set reference voltage setting resistor for maximum resistance. Set for maximum resistance by insulating movable slider from wirewound element, Fig. 6.

CAUTION: Before proceeding make certain that variable voltage control on test power supply is at minimum setting.

9. Turn power supply on. Slowly increase supply voltage to regulator. Observe both the power supply voltmeter and test lamp. Match the voltmeter and test lamp indications with the corresponding indication in Fig. 7. Proceed to Step 10 only after the regulator displays the normal indication.
10. Turn voltage adjusting rheostat RH, on front of regulator, for minimum resistance (full travel counterclockwise from front).
11. On regulators equipped with the 72 volt reference feature, attach a jumper wire across end terminals of reference voltage setting resistor R1, as in Step 5 above.
12. Connect a voltohmmeter (VOM) to test circuit as shown in Fig. 8. Connect positive lead from VOM to F terminal of regulator. Connect a .1 microfarad capacitor in series between negative (common) lead from VOM and negative terminal of regulator.

INDICATION	MALFUNCTION	REMEDY
Lamp becomes bright and goes off between 62 and 70 volts.	Normal indication for this test. Proceed to Step 7 for next test.	Proceed to Step 7 for next test.
Lamp becomes brighter and goes off at some point higher than 70 volts.	Voltage is regulated too high.	Perform Procedure A in Troubleshooting And Repair Section.
Lamp becomes brighter and goes off at some point lower than 62 volts. NOTE: Ensure that test lamp did not go off when starting relay SR picked up. See indication below.	Voltage is regulated too low.	Perform Procedure A in Troubleshooting And Repair Section.
Test lamp goes off when starting relay SR picks up at approximately 30 to 48 volts.	Regulator is not turning on.	Perform Procedure B in Troubleshooting And Repair Section.
Test lamp does not come on or is very dim.	Regulator is not turning on.	Perform Procedure B in Troubleshooting And Repair Section.
Test lamp does not go off.	Regulator is not turning off.	Perform Procedure B in Troubleshooting And Repair Section.

Fig. 5 - Indication Chart For Step 6

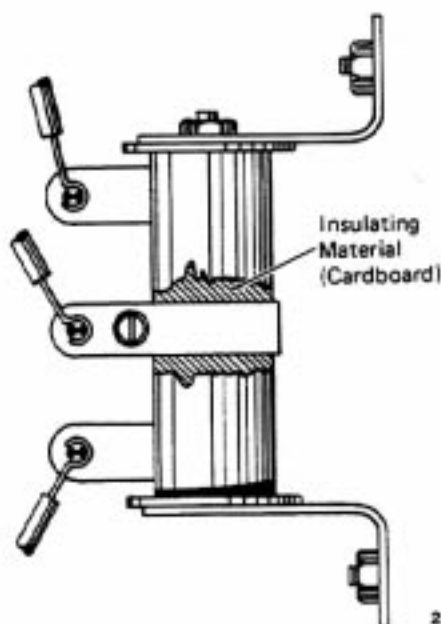

Fig. 6 - Setting Reference Voltage Resistor For Maximum Resistance

INDICATION	MALFUNCTION	REMEDY
Lamp becomes bright and goes off between 76 and 87 volts.	Normal indication for this test. Proceed to Step 10 for next test.	Proceed to Step 10 for next test.
Lamp becomes brighter and goes off at some point higher than 87 volts.	Voltage is regulated too high.	Perform Procedure A in Troubleshooting And Repair Section.
Lamp becomes brighter and goes off at some point lower than 76 volts. NOTE: Ensure that test lamp did not go off when starting relay SR picked up. See indication below.	Voltage is regulated too low.	Perform Procedure A in Troubleshooting And Repair Section.
Test lamp goes off when starting relay SR picks up at approximately 30 to 48 volts.	Regulator is not turning on.	Perform Procedure B in Troubleshooting And Repair Section.
Test lamp does not come on or is very dim.	Regulator is not turning on.	Perform Procedure B in Troubleshooting And Repair Section.
Test lamp does not go off.	Regulator is not turning off.	Perform Procedure B in Troubleshooting And Repair Section.

Fig. 7 - Indication Chart For Step 9

13. Set VOM controls for minimum AC volt range over 10 volts.

CAUTION: Before proceeding make certain that variable voltage control on test power supply is at minimum setting.

14. Turn power supply on. Slowly increase supply voltage to regulator. Observe both power supply voltmeter and the VOM. AC voltages indicated by VOM should correspond with DC voltages indicated by power supply voltmeter as shown in Fig. 9.

NOTE: The sharp jump in AC voltage from zero at approximately 50 volts DC indicates that regulator is oscillating. The AC voltage is given only as a reference and varies widely depending on meter used to measure it.

In normal operation the regulator may start oscillating before 50 volts DC. If regulator fails to oscillate, perform Procedure B in the Troubleshooting And Repair section.

The regulator is operating satisfactorily if it displays all normal indications as called for in the preceding functional tests. The regulator is ready to be put back into service. Calibrate by following procedure in Calibrating Regulator section.

TROUBLESHOOTING AND REPAIR

This section when used in conjunction with the Functional Test section is intended as a guide for troubleshooting. To avoid possibility of injury to personnel or damage to equipment, service personnel should have an understanding of the

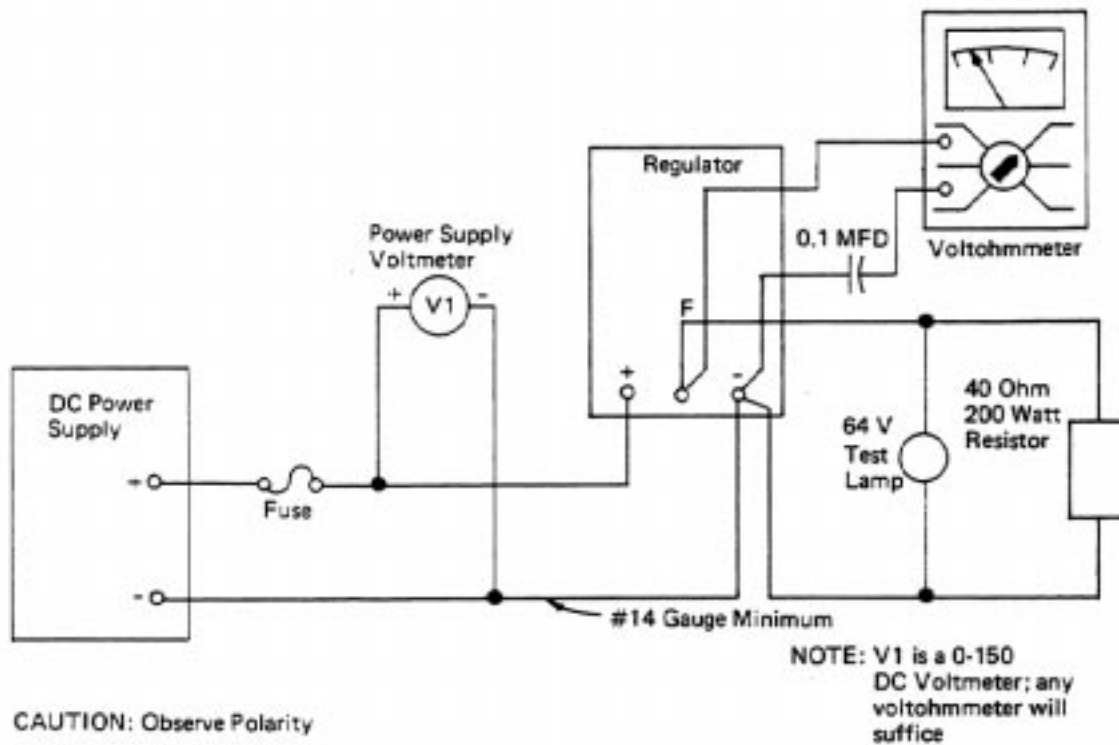

Fig. 8 - Regulator Test Circuit

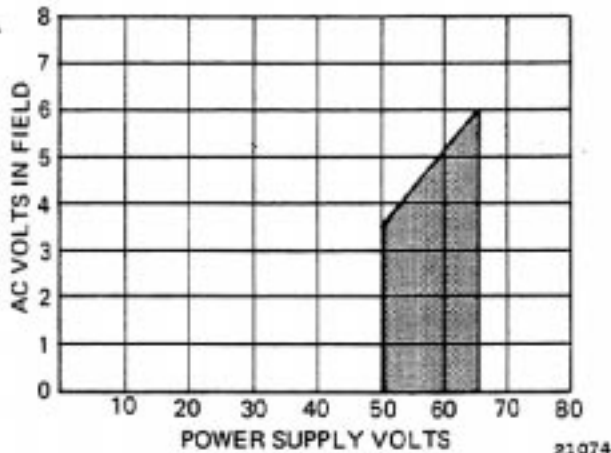

Fig. 9 - Approximate AC Voltage In Field With Respect To Test Power Supply Voltage

equipment and a cognizance of safety practices. Read entire procedure including all notes, cautions, and warnings before performing following steps. When a defective part is located, refer to Component Renewal section for General Workmanship practices.

NOTE: Check wiring of starting relay SR, Fig. 10, before proceeding.

PROCEDURE A

1. Remove four screws and washers that secure the back cover to the cabinet, remove back cover, Fig. 11.

2. Unscrew four screws, washers, and rubber cushions that secure printed circuit board to cabinet. Note location of rubber cushions between printed circuit board and mounting tangs, Fig. 12.
3. Check resistors R2 and R3, Fig. 16, using a volt ohmmeter. Refer to Service Data. If meter does not indicate 297 to 303 ohms, resistor is defective and should be replaced.
4. Check resistance of R7, Fig. 16. If ohmmeter does not indicate 47.5 to 52.5 ohms, resistor is defective and should be replaced. Refer to Component Renewal section.
5. On three terminal regulators, check resistance of rheostat RH, on front of regulator. Set control for maximum resistance (full travel clockwise from front). If ohmmeter does not indicate 90 to 110 ohms, RH is defective and should be replaced.
6. On regulators equipped with 72 volt reference feature, check resistance of reference voltage setting resistor R1, Fig. 13. Insulate movable slider from wirewound element, Fig. 19. If ohmmeter does not indicate 90 to 110 ohms, R1 is defective and should be replaced.

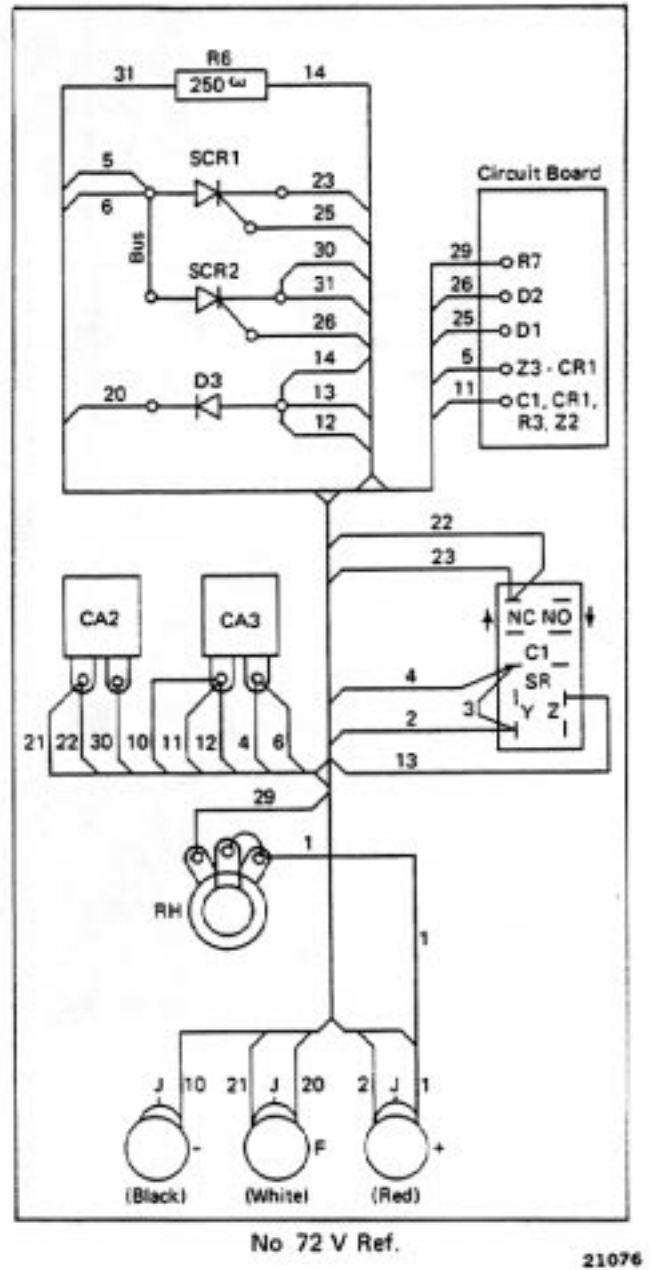
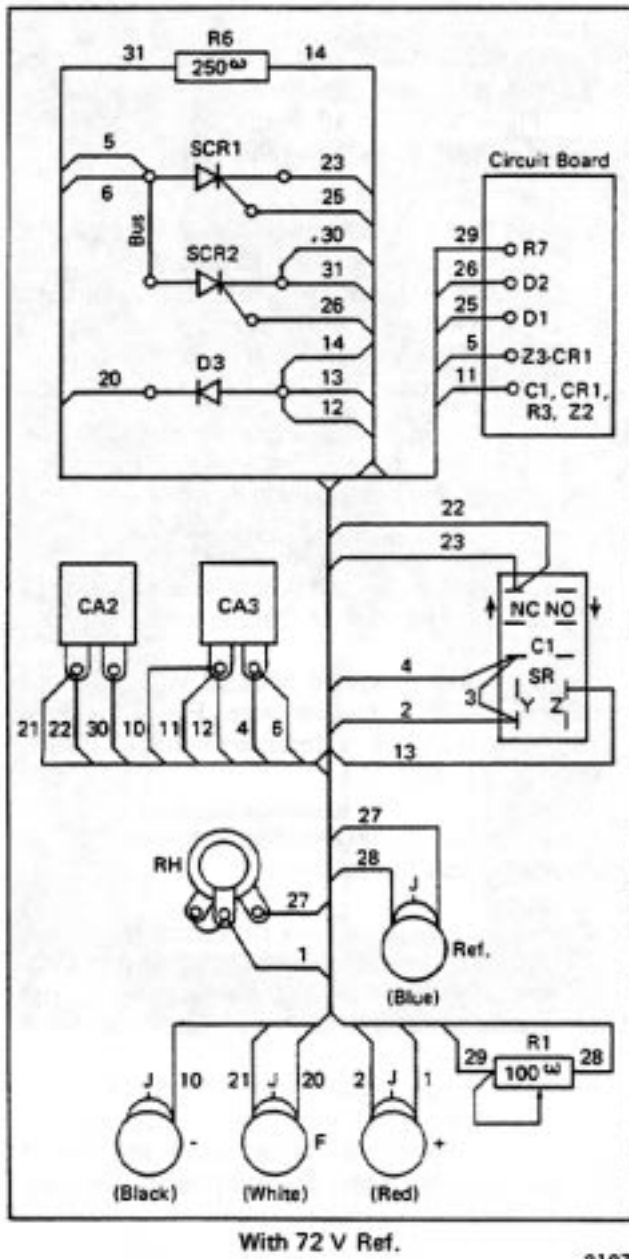
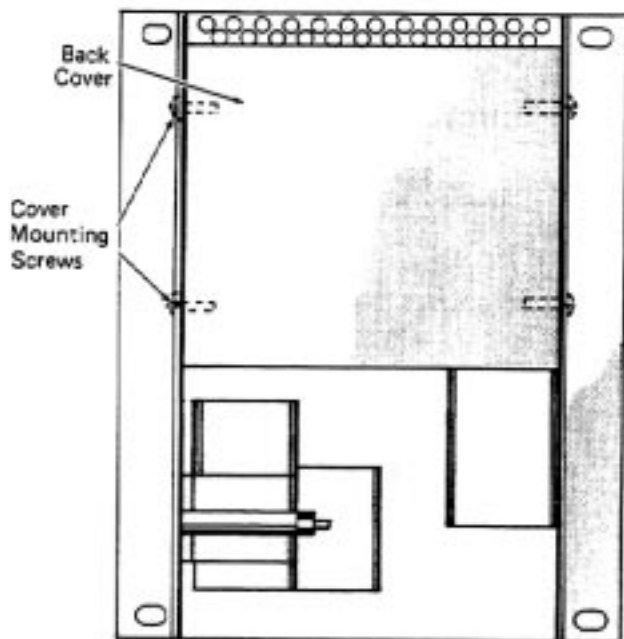
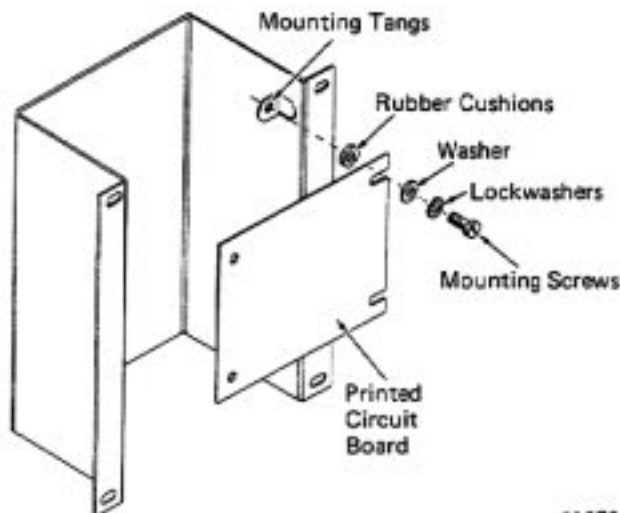

Fig. 10 - Physical Schematic Diagram



21077

Fig. 11 - Removing Back Cover



21078

Fig. 12 - Removing Printed Circuit Board

7. Check resistance across parallel combination of thermistor T1 and resistor R4, test points **F** and **G**, Fig. 16.

- a. If ohmmeter indicates 21 to 27 ohms proceed to Step 8. If indication is other than 21 to 27 ohms perform b.
- b. Disconnect one terminal of R4. Check resistance of R4 and T1 individually. Resistance of R4 should be 44 to 50 ohms. Resistance of T1 should be 45 to 55 ohms at room temperature. Defective component should be replaced. Refer to Component Renewal section.

8. Perform Step 7 substituting the parallel combination of thermistor T2 and resistor R5, test points **D** and **E**, Fig. 16.

9. Place circuit board, printed side down, on the starting relay and capacitors C2 and C3, Fig. 13. Place a piece of insulating material between circuit board and bare metal to prevent a short circuit.

CAUTION: Make certain that test power supply is off before making any electrical connections to regulator. Observe polarity. If positive and negative leads are reversed, costly internal damage will result.

10. Connect regulator in the test circuit shown in Fig. 20. See Service Data for information concerning test components.

11. Turn voltage adjusting rheostat RH, on front of regulator, for minimum resistance (full travel counterclockwise from front).

12. On regulators equipped with 72 volt reference feature, attach a jumper wire, Fig. 21, across end terminals of reference voltage setting resistor R1, Fig. 13.

13. Check zener diode Z1, Fig. 16, using a DC voltmeter and the following:

- a. Connect positive lead of voltmeter to the cathode (solder lug) of Z1, Fig. 18. Connect negative lead to the anode (stud mount) of Z1.
- b. Vary supply voltage from 50 to 70 volts. If voltage at Z1 varies more than ± 1 volt from 26 volts, Z1 is defective and should be replaced. Refer to Component Renewal section.
- c. Repeat procedure, substituting Z2 for Z1.

14. Mount printed circuit board to cabinet using the four screws, washers, and rubber cushions removed in Step 2. Make certain that rubber cushions are located between circuit board and cabinet mounting tangs.

15. Install back cover using the four screws and washers removed in Step 1.

16. Perform steps under Functional Test section. If regulator displays all normal indications, unit is ready for service. Refer to Calibrating Regulator section.

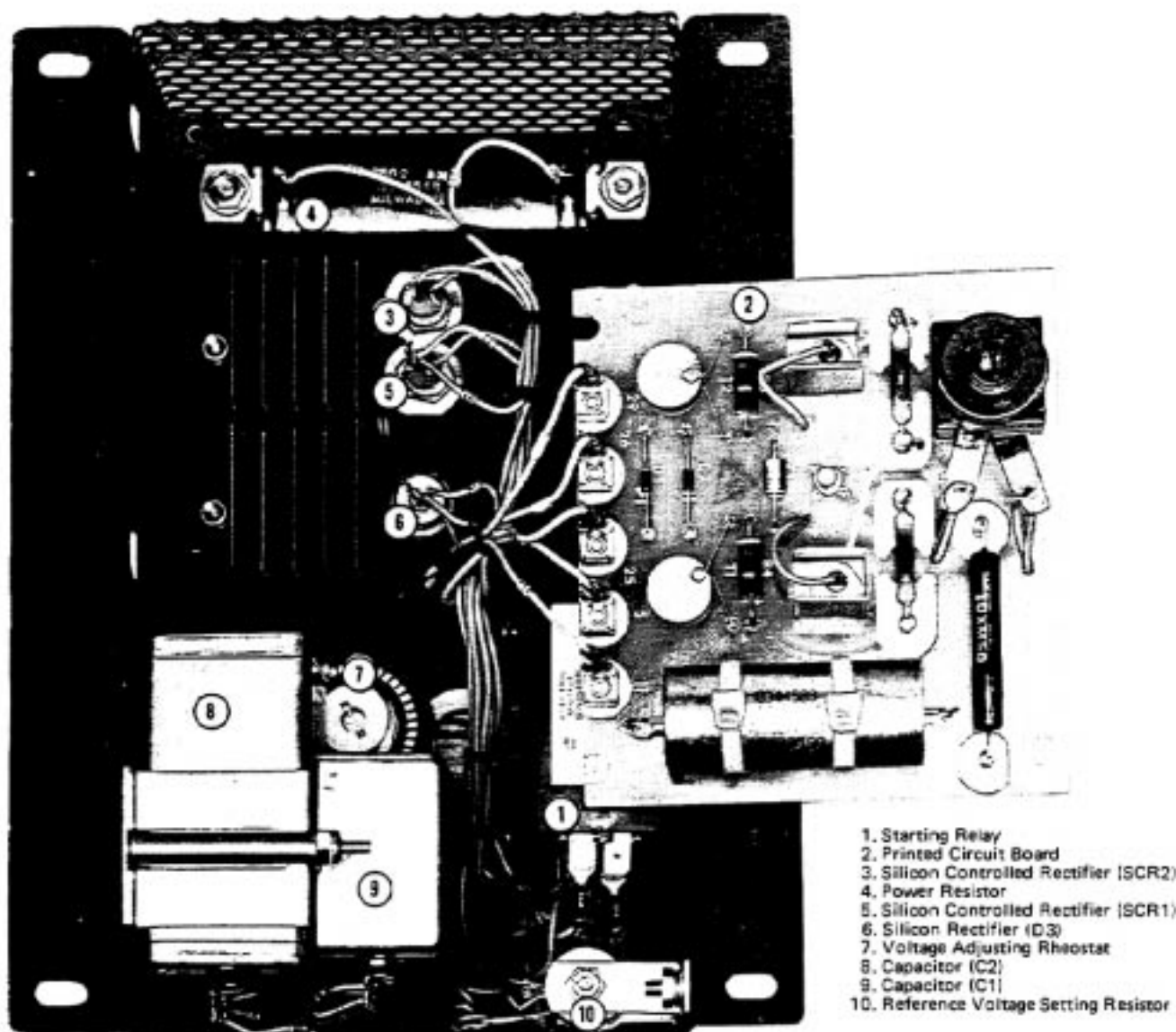

Fig. 13 - Parts Layout

21079

The preceding checks should be sufficient to find most problems normally encountered when the regulator is regulating either too high or too low. Perform Procedure B if regulator is still inoperative.

PROCEDURE B

1. Remove four screws and washers that secure the back cover to cabinet, remove back cover, Fig. 11.
2. Unscrew four screws, washers, and rubber cushions that secure printed circuit board to cabinet. Note location of rubber cushions between printed circuit board and mounting tangs, Fig. 12.

3. Remove all five wires connected to printed circuit board, remove board, Fig. 13.
4. Remove wires marked 22 and 23 from NC1 terminal on starting relay SR, Fig. 10.

NOTE: Ensure that good connections are made when checking a component. If necessary scrape varnish and dirt off test point.

5. Check silicon controlled rectifier SCR1, Fig. 13, using two battery test lights. See Service Data, and the following procedure.

CAUTION: Renew all failed components and repeat checks until all normal indications are obtained.

- a. Connect positive lead of one battery test light to negative lead of the other test light, Fig. 14. This arrangement will supply the full five volts necessary to check these semiconductors.

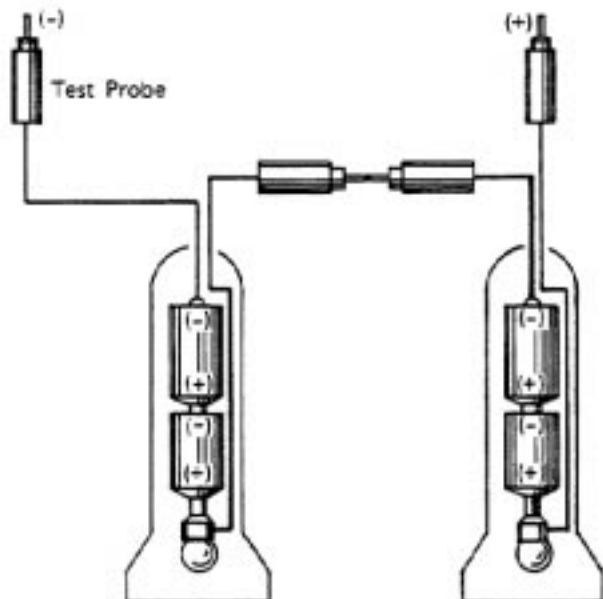

Fig. 14 - Connecting Two Battery Test Lights In Series 21080

- b. Connect negative lead of test light to anode (stud mount) of SCR1, Fig. 15. It is not necessary to physically connect the test lead to the anode. Wire tagged with the number 5, removed from the printed circuit board, is common to the anode of both SCR's.
- c. Connect positive lead to cathode (large solder lug) of SCR1, Fig. 15.

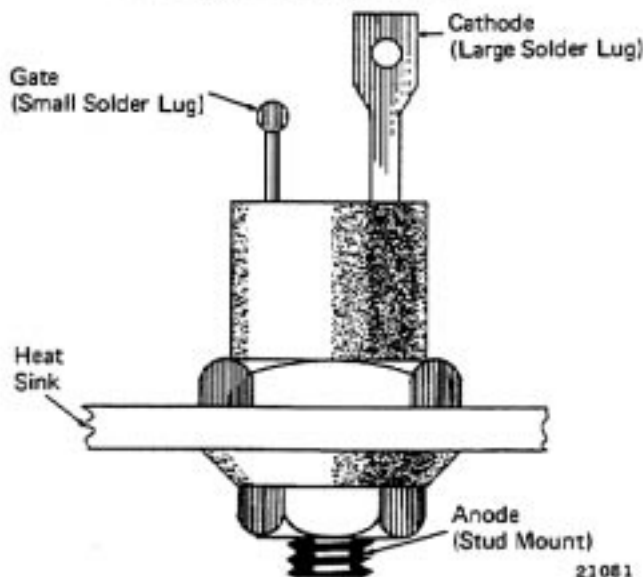

Fig. 15 - Silicon Controlled Rectifier Terminals 21081

- d. If battery test light does not come on, proceed to e. If light does come on, SCR is defective (short circuit) and should be replaced. Refer to Component Renewal section.
- e. Reverse test light leads. Connect positive lead to anode (stud mount) and negative lead to cathode (large solder lug) of SCR1.
- f. If battery test light does not come on proceed to g. If light does come on, SCR is defective (short circuit) and should be replaced. Refer to Component Renewal section.
- g. Connect a jumper to wire tagged with the number 5 (anode of SCR). Touch other end to gate (small solder lug) of SCR being checked, Fig. 15.
- h. If battery test light comes on and stays on when gate signal is removed, proceed to Step 6. If light does not come on or if it comes on but does not stay on, SCR is defective (open circuit) and should be replaced. Refer to Component Renewal section.

6. Perform Step 5 substituting SCR2 for SCR1.

7. Check diode D1, Fig. 16, using a battery test light, see Service Data, and the following procedure. A schematic diagram of the entire voltage regulator circuit, Fig. 17, is included for reference.

- a. Connect positive lead of test light to anode of D1, Fig. 16. Connect negative lead to cathode of D1.
- b. If battery test light comes on, proceed to c. If light does not come on, D1 is defective (open circuit) and should be replaced. Refer to Component Renewal section.
- c. Reverse test light leads. Negative lead to anode and positive lead to cathode of D1, Fig. 16.
- d. If test light does not come on proceed to Step 8. If light does come on, D1 is defective (short circuit) and should be replaced. Refer to Component Renewal section.

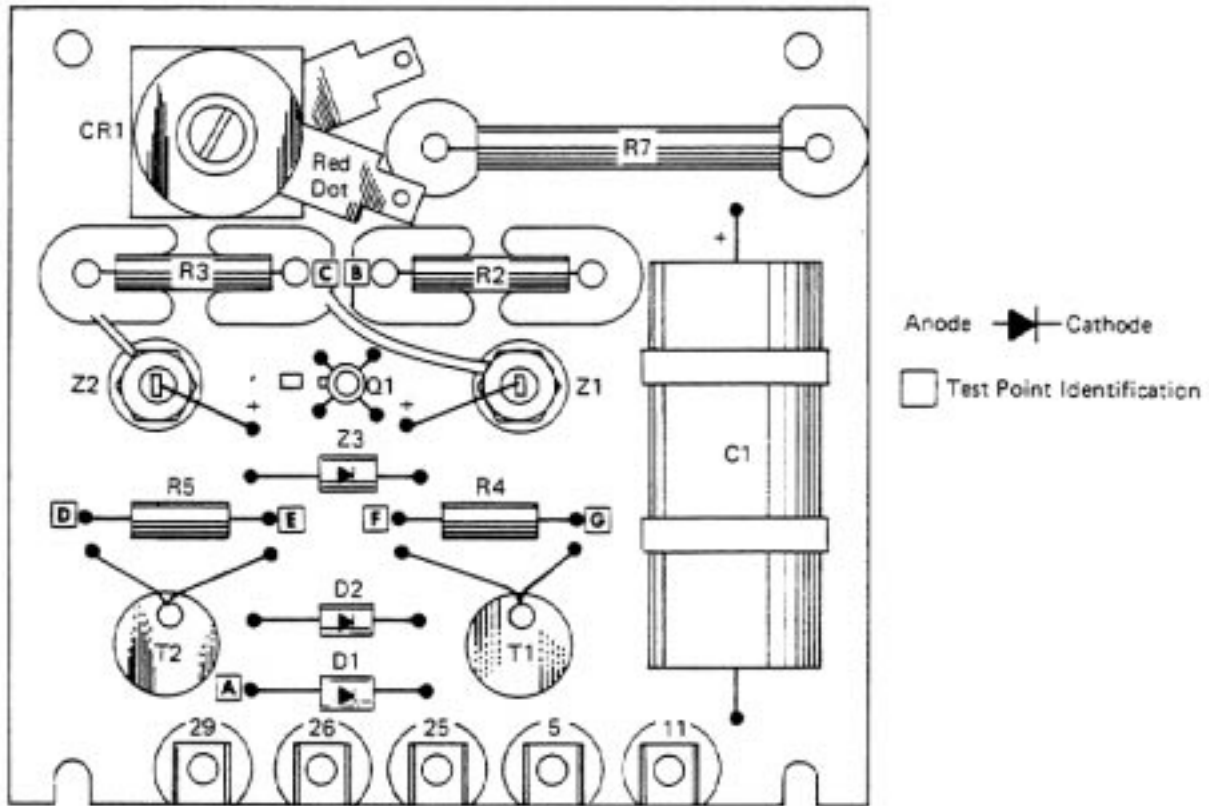
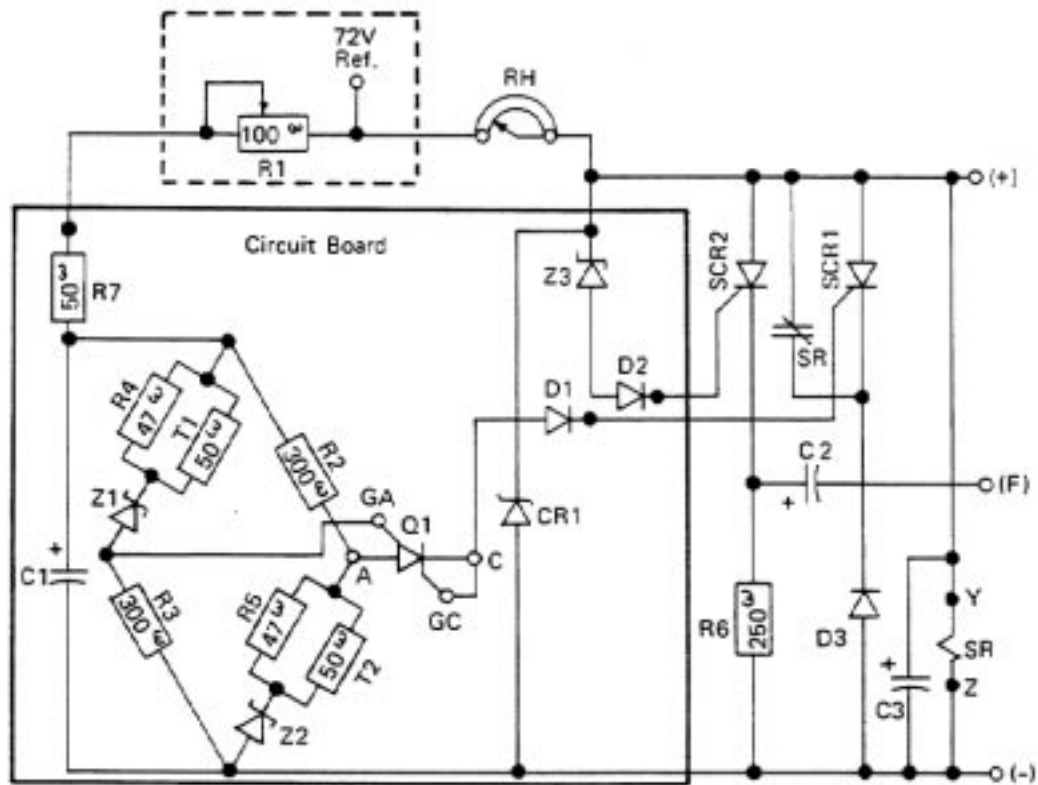

Fig. 16 - Printed Circuit Board Test Points

21082



NOTE: Components shown in dotted outline are present only on regulators equipped with the 72 volt reference feature.

Fig. 17 - Schematic Diagram

21083

8. Check silicon rectifier D3, Fig. 13, using a battery test light, see Service Data, and the following procedure.

- a. Connect positive lead of tester to anode (solder lug) of D3. Connect negative lead to F terminal on front of regulator.
- b. If test light comes on proceed to c. If light does not come on, D3 is defective (open circuit) and should be replaced. Refer to Component Renewal section.
- c. Reverse test light leads. Positive lead to F terminal on regulator and negative lead to anode (solder lug) of D3.
- d. If test light does not come on proceed to Step 9. If light comes on, D3 is defective (short circuit) and should be replaced. Refer to Component Renewal section.

NOTE: Ensure that good connections are made when checking a component. If necessary scrape varnish and dirt off test point.

9. Check silicon controlled switch Q1, Fig. 16, using a battery test light, see Service Data, and the following procedure.

- a. Connect positive lead of test light to cathode and cathode gate of Q1, test point **A**, Fig. 16.
- b. Touch negative lead of test light to anode, test point **B**, of Q1. If light does not come on proceed to d.
- c. If light comes on Q1 is defective (short circuit), and should be replaced. Refer to Component Renewal section.
- d. Touch negative lead of test light to anode gate, test point **C**, of Q1.
- e. If test light comes on proceed to f. If light does not come on, Q1 is defective (open circuit) and should be replaced. Refer to Component Renewal section.
- f. Connect negative lead of test light to cathode and cathode gate, test point **A**, of Q1.
- g. Touch positive lead of test light to anode, test point **B**, and then anode gate, test point **C**, of Q1.

- h. If test light does not come on proceed to i. If light comes on Q1 is defective (short circuit) and should be replaced. Refer to Component Renewal section.
- i. Connect positive lead of test light to anode, test point **B**, of Q1.
- j. Touch a jumper wire between cathode, test point **A**, and anode gate, test point **C**, of Q1.
- k. If test light comes on and stays on when gate signal is removed proceed to Step 10. If light does not come on or if it comes on but does not stay on, Q1 is defective and should be replaced. Refer to Component Renewal section.

10. Check zener diode Z1, Fig. 16, using a battery test light, see Service Data, and the following procedure.

- a. Connect positive lead of test light to anode (stud mount) and negative lead to cathode (solder lug) of Z1, Fig. 18.

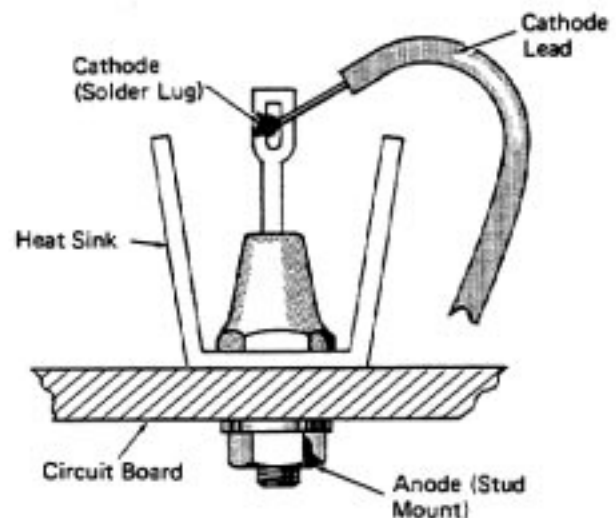

Fig. 18 - Stud Mounted Zener Diode

21084

- b. If test light comes on proceed to c. If light does not come on Z1 is defective (open circuit) and should be replaced. Refer to Component Renewal section.
- c. Reverse test light leads. Positive to cathode, (solder lug) and negative to anode (stud mount) of Z1.
- d. If test light does not come on, proceed to Step 11. If light comes on Z1 is defective (short circuit) and should be replaced. Refer to Component Renewal section.

11. Perform Step 10 substituting Z2 for Z1.
12. Check resistors R2 and R3, Fig. 16, using a volt-ohmmeter, see Service Data. If meter does not indicate 297 to 303 ohms, resistor is defective and should be replaced.
13. Check resistance of R7, Fig. 16. If ohmmeter does not indicate 47.5 to 52.5 ohms, resistor is defective and should be replaced. Refer to Component Renewal section.
14. On three terminal regulators, check resistance of rheostat RH, on front of regulator. Set control for maximum resistance (full travel clockwise from front). If ohmmeter does not indicate 90 to 110 ohms, RH is defective and should be replaced.
15. On regulators equipped with 72 volt reference feature, check resistance of reference voltage setting resistor R1, Fig. 13. Insulate movable slider from wirewound element, Fig. 19. If ohmmeter does not indicate 90 to 110 ohms, R1 is defective and should be replaced.

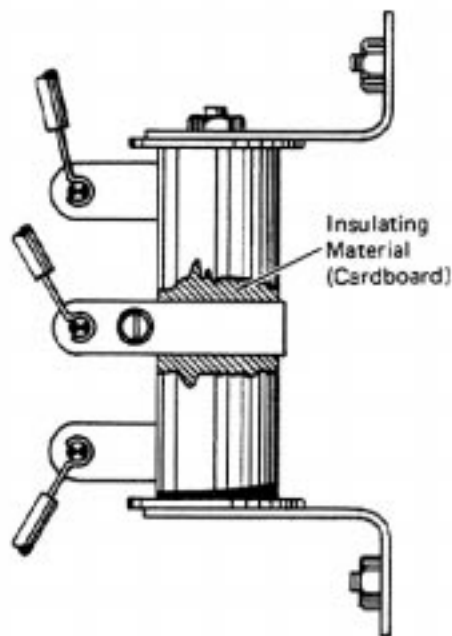

Fig. 19 - Setting Reference Voltage Resistor For Maximum Resistance

16. Check resistance across parallel combination of thermistor T1 and resistor R4, test points **F** and **G**, Fig. 16.
 - a. If ohmmeter indicates 21 to 27 ohms proceed to Step 17. If indication is other than 21 to 27 ohms perform b.
 - b. Disconnect one terminal of R4. Check resistance of R4 and T1 individually. Resistance of R4 should be 44 to 50 ohms. Resistance of T1 should be 45 to

55 ohms at room temperature. Defective component should be replaced. Refer to Component Renewal section.

17. Perform Step 16, substituting the parallel combination of thermistor T2 and resistor R5, test points **D** and **E**.
18. Reconnect wires tagged 29, 26, 5, 11, and 25 to corresponding terminal on printed circuit board, Fig. 13.
19. Reconnect wire tagged 22 and 23 to NC1 terminal of starting relay SR, Fig. 10.
20. Place circuit board, printed side down, on the starting relay and capacitors C2 and C3, Fig. 13. Place a piece of insulating material between circuit board and bare metal to prevent a short circuit.

CAUTION: Make certain that test power supply is off before making any electrical connections to regulator. Observe polarity. If positive and negative leads are reversed, costly internal damage will result.

21. Connect regulator in the test circuit shown in Fig. 20. See Service Data for information concerning test components.
22. Turn voltage adjusting rheostat RH, on front of regulator, for minimum resistance (full travel counterclockwise from front).
23. On regulators equipped with 72 volt reference feature, attach a jumper wire, Fig. 21, across end terminals of reference voltage setting resistor R1, Fig. 13.
24. Connect positive lead of a DC voltmeter to the anode, test point **B**, of Q1, Fig. 16. Connect negative lead to the anode gate, test point **C**, of Q1.

CAUTION: Before proceeding make certain that variable voltage control on test power supply is at minimum setting.

25. Turn power supply on. Slowly increase supply voltage (V1) to regulator from 0 to 70 volts. Observe both the power supply voltmeter and voltmeter connected to the anode and anode gate of Q1. Anode voltage with respect to anode gate voltage (V2) should be as shown in Fig. 22.

At the time V2 reverses polarity the test lamp should go out. Power supply voltage V1, may vary between 62 and 70 volts. Proceed to Step 27 if regulator displays this indication. If V1 is increased above 75 volts and V2 does not reverse polarity, proceed to Step 26.

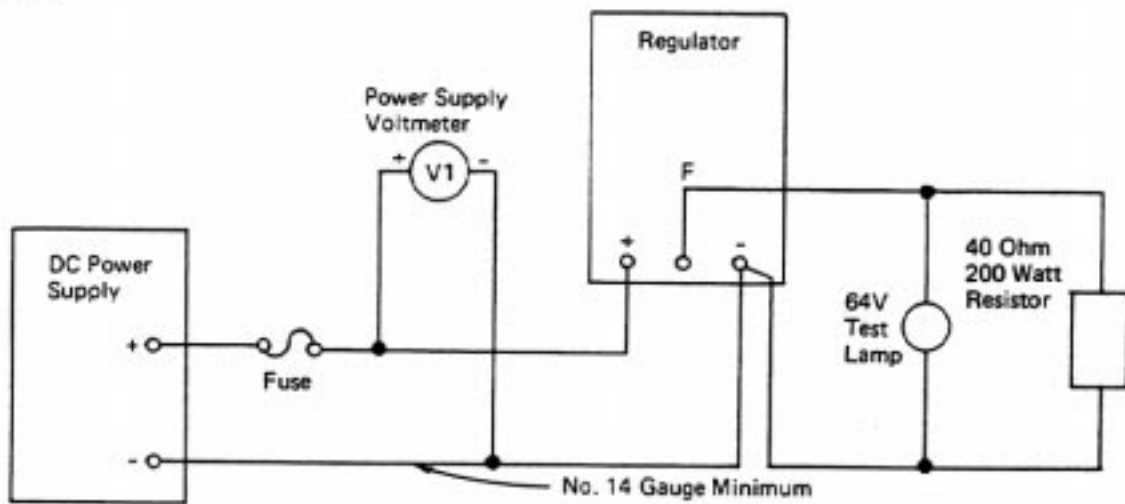

CAUTION: Observe Polarity

NOTE: V1 is a 0-150 DC Voltmeter; any voltohmmeter will suffice

21070

Fig. 20 - Regulator Test Circuit

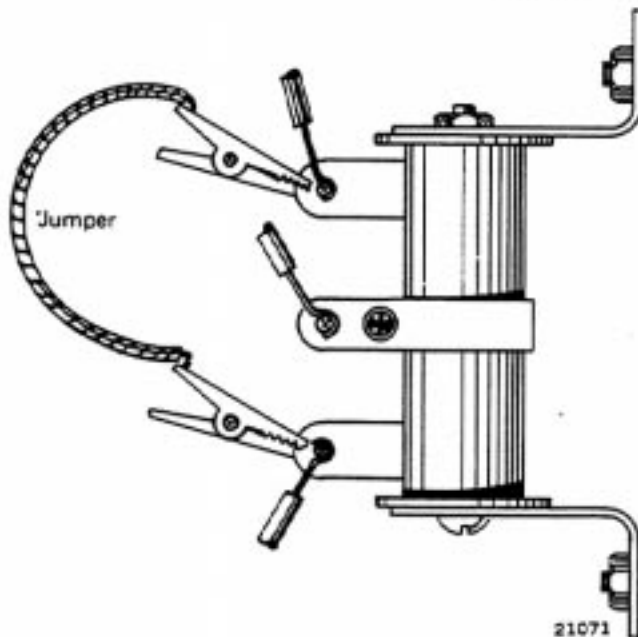

Fig. 21 - Shorting Reference Voltage Resistor

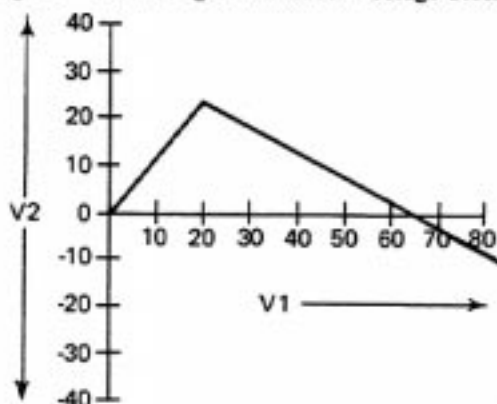

Fig. 22 - Anode Voltage With Respect To Anode Gate Voltage

21088

26. Check zener diode Z1, Fig. 16, using a DC voltmeter and the following.

- a. Connect positive lead of voltmeter to the cathode (solder lug) of Z1, Fig. 18. Connect negative lead to the anode (stud mount) of Z1.
- b. Vary supply voltage from 50 to 70 volts. If voltage at Z1 varies more than ± 1 volt from 26 volts, Z1 is defective and should be replaced. Refer to Component Renewal section.
- c. Repeat procedure substituting Z2 for Z1.
- d. Repeat Step 25.

CAUTION: Before proceeding make certain that variable voltage control on test power supply is at minimum setting.

27. Connect negative lead of a DC voltmeter to terminal 11 of printed circuit board. Connect positive lead to anode of D1, Fig. 16.

28. Slowly increase supply voltage (V1) to regulator from 0 to 80 volts. Observe both the power supply voltmeter and voltmeter connected to D1. Voltage (V2) at anode of D1 should be as shown in Fig. 23.

Drop off of voltage V2 should take place when V1 is between 62 and 70 volts, coinciding with the polarity reversal noted in Step 25. Proceed to Step 29 if regulator displays

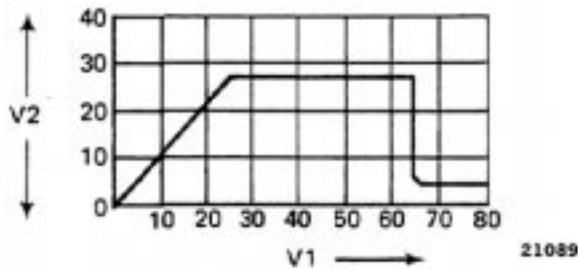

Fig. 23 - Voltage At Anode Of D1

this indication. Silicon controlled switch Q1 is defective and should be replaced if regulator displays any other indication. Refer to Component Renewal section.

CAUTION: Make certain that test power supply is off before making any electrical connections to regulator. Observe polarity. If positive and negative leads are reversed, costly internal damage will result.

29. Connect positive and negative leads of power supply to regulator, as shown in Fig. 24.

NOTE: Do not connect 40 ohm resistor and test lamp to the regulator.

30. Connect positive lead of a DC voltmeter to the cathode (large solder lug) SCR2, Fig. 25. Connect the negative lead to terminal 11 of the printed circuit board.

CAUTION: Before proceeding make certain that variable voltage control on test power supply is at minimum setting.

31. Turn power supply on. Slowly increase supply voltage from zero to 45 volts.

32. The voltmeter connected to the cathode of SCR2 should read zero until supply voltage is approximately 40 volts at which time it should jump to 40 volts. If regulator displays this indication proceed to Step 35. If voltage at cathode of SCR2 remains at zero proceed to Step 33.

33. Check diode D2, Fig. 16, using a battery test light, see Service Data, and the following procedure.

- Connect positive lead of test light to anode of D2, Fig. 16. Connect negative lead to the cathode of D2.
- If test light comes on, proceed to c. If light does not come on, D2 is defective (open circuit) and should be replaced. Refer to Component Renewal section.
- Reverse test light leads. Negative lead to anode and positive lead to cathode of D2.
- If test light does not come on, D1 is defective (short circuit) and should be replaced. Refer to Component Renewal section.

34. Check zener diode Z3, Fig. 16, using a battery test light, see Service Data, and the following procedure.

- Connect positive lead of test light to anode of Z3, Fig. 16. Connect negative lead to the cathode of Z3.
- If test light comes on, proceed to c. If light does not come on, Z3 is defective (open circuit) and should be replaced. Refer to Component Renewal section.

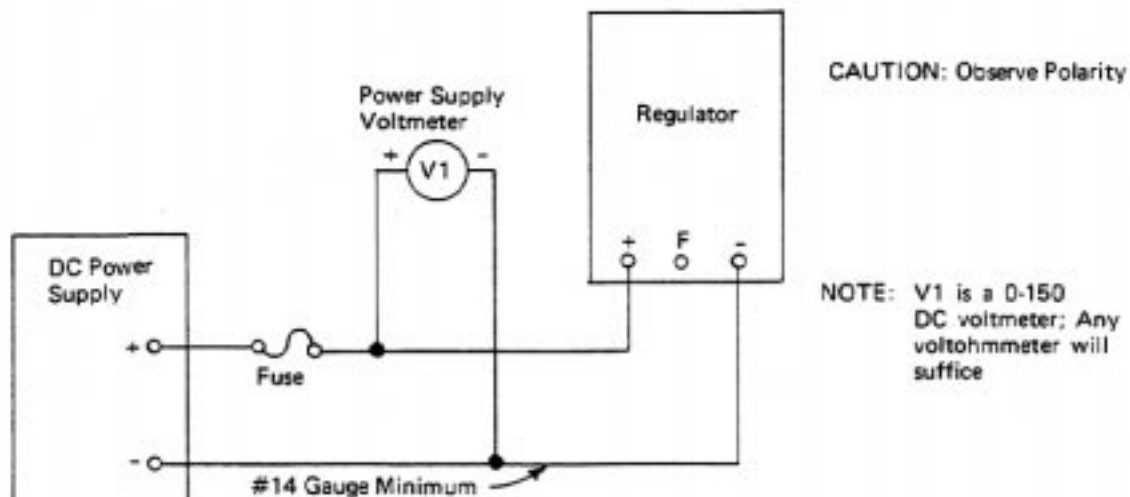

Fig. 24 - Regulator Test Circuit

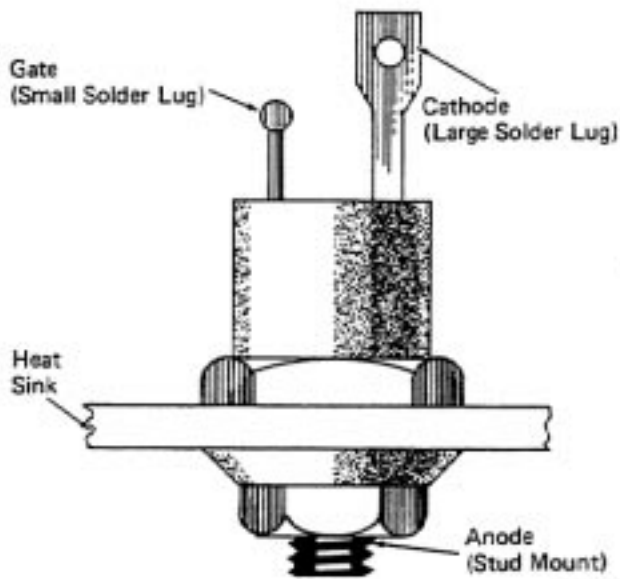

Fig. 25 - Connection to SCR2

- c. Reverse test light leads. Negative lead to anode and positive lead to cathode of Z3.
 - d. If test light does not come on, proceed to Step 35. If light comes on, Z3 is defective (short circuit) and should be replaced. Refer to Component Renewal section.
35. Mount printed circuit board to cabinet using the four screws, washers, and rubber cushions removed in Step 2. Make certain that rubber cushions are located between circuit board and cabinet mounting tangs.
 36. Install back cover using the four screws and washers removed in Step 1.
 37. Perform steps under Functional Tests section. If regulator displays all normal indications, unit is ready for service. Refer to Calibrating Regulator section.

The preceding checks should be sufficient to find most problems normally encountered with inoperative regulators. Wires burned or creating short circuits will have to be found by other means.

COMPONENT RENEWAL

This section has been included to present suggested practices essential to renewing defective components. Before renewing any component read the General Workmanship section.

Certain components have a separate section pertaining specifically to that component. This

section is intended to be used in conjunction with the recommendations presented in the General Workmanship section. Refer to Service Data for information concerning part numbers and descriptions of items referred to below.

GENERAL WORKMANSHIP

- Solder recommended for use on electronic components is 1.6 mm (1/16") wire solder composed of 60% tin and 40% lead with a resin core.
- A heat sink must be used on all semiconductor components to prevent heat damage while soldering. Examples of components that require heat sinks are; Diodes D-, Zener Diodes Z-, Silicon Controlled Rectifiers SCR-, and the Silicon Controlled Switch Q1. If more than one semiconductor lead is to be soldered to a terminal, make certain that all leads to be soldered have heat sinks applied.
- Use epoxy to secure replacement parts to circuit board.
- Use a soldering iron that has sufficient capacity to heat the solder joint to $274^{\circ}\text{C} \pm 14^{\circ}$ ($525^{\circ}\text{F} \pm 25^{\circ}$) in one or two seconds. Avoid using a soldering gun.
- Recommended replacement wire is teflon insulated No. 18 gauge stranded type wire.
- Whenever a component is replaced on the printed circuit board it must be sealed with a conformal coating. A new part may be painted alone or the entire board may be dipped. Take precautions to prevent conformal coating from covering wire connecting terminals on printed circuit board. Allow a few hours drying time.
- Observe polarity of all polarized components.

SCR - SILICON CONTROLLED RECTIFIER

1. Remove three nuts that secure SCR heat sink to cabinet. Note location of insulators.
2. Unsolder all wires connected to the SCR.
3. Remove mounting stud nut, plain washer, and lock tooth washer. Pull defective SCR from heat sink.

NOTE: When installing SCR, torque mounting stud nut to 3.4 N·m (30 in.-lbs).

4. Review General Workmanship practices.
5. Install new SCR by reversing Steps 1 through 3.

D3 - SILICON RECTIFIER

1. Remove three nuts that secure D3 heat sink to cabinet. Note location of insulators.
2. Unsolder all wires connected to D3.
3. Remove mounting stud nut, plain washer, and lock tooth washer. Pull defective D3 from heat sink.

NOTE: When installing D3, torque mounting stud nut to 3.4 N·m (30 in.-lb).

4. Review General Workmanship practices.
5. Install new D3 by reversing Steps 1 through 3.

Q1 - SILICON CONTROLLED SWITCH

1. Unsolder all four Q1 leads from bottom of circuit board. Remove defective Q1.
2. Insert leads from new Q1 through holes in lead conversion pad.
3. Insert leads through holes in circuit board. Refer to Fig. 26. Match small tab on Q1 with identification mark on printed circuit board.
4. Review General Workmanship practices.
5. Solder leads to their proper location, Fig. 26.

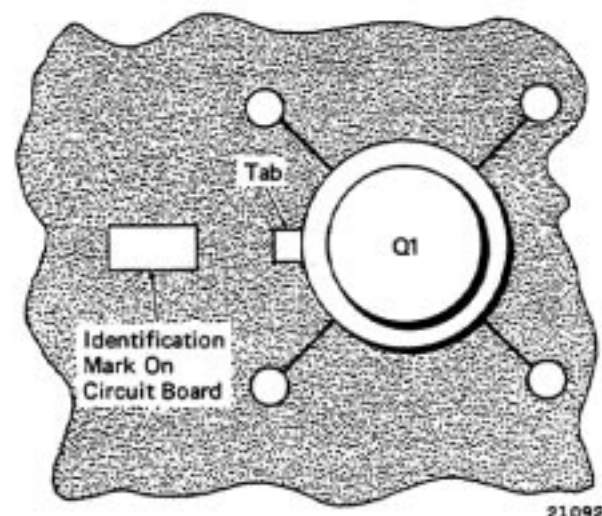

Fig. 26 - Mounting Q1

6. Clip leads as close to board as possible.

Z - STUD MOUNTED ZENER DIODE

1. Unsolder cathode lead from solder lug of zener diode, Fig. 27.

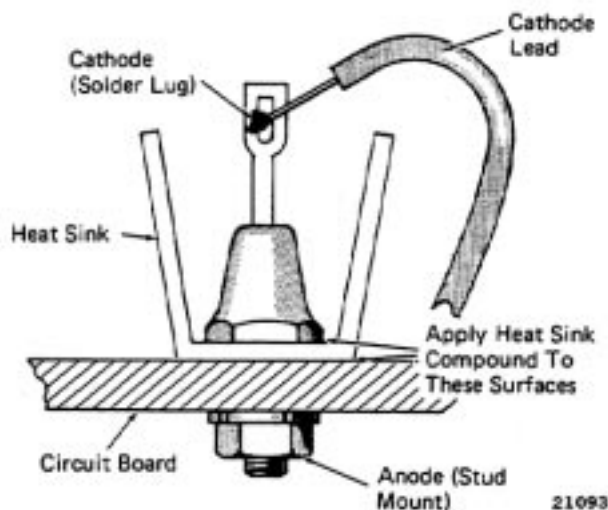

Fig. 27 - Replacing Stud Mounted Zener Diodes

2. Remove mounting stud nut, plain washer, and lock washer. Pull defective zener and heat sink from circuit board.
3. Apply a thin coat of heat sink compound to the surfaces of the heat sink that will contact circuit board copper and shoulder of zener. Do not apply compound to threads of mounting stud.
4. Mount new zener to heat sink. Mount assembly to circuit board.
5. Review General Workmanship practices.
6. Solder cathode lead to new zener.

CALIBRATING REGULATOR

When it has been determined that the voltage regulator is operating satisfactorily it is ready to be installed in the high voltage cabinet of a locomotive. While installing regulator, calibrate it to regulate at desired voltage by performing the following steps.

1. Turn voltage adjusting rheostat RH, on front of regulator, to minimum resistance (full travel counterclockwise from front).
2. On regulators equipped with the 72 volt reference feature, set reference voltage setting resistor R1 for minimum resistance by moving adjustable slider.

WARNING: Do not make any electrical connections to regulator while engine is running. Severe arcing and/or burns may result.

3. Make proper electrical connections to regulator.

NOTE: Do not mount regulators equipped with 72 volt reference feature at this time. Provide for access to reference voltage setting resistor.

4. Mount regulators not equipped with 72 volt reference feature to high voltage cabinet.
5. Use Procedure A for regulators equipped with 72 volt reference feature. Use Procedure B for all other regulators.

PROCEDURE A

1. Connect positive lead of a DC voltmeter to the 72 volt reference terminal on front of regulator. Connect the negative lead to the negative terminal.

CAUTION: Perform all necessary prestart procedures. Run engine at full throttle only as long as necessary to set regulator for 72 volts. Avoid continuous running of engine at full throttle with no load.

2. Start engine. Run engine at full throttle while performing Step 3 below.
3. Adjust slider on reference voltage setting resistor until voltmeter reads 72 volts $\pm 1/2$ volt.
4. Reduce throttle to Run 5 position.

NOTE: As the auxiliary generator and regulator resistors warm up the voltage will have a tendency to increase slightly. Allow the throttle to remain in Run 5 position until voltage stabilizes.

5. Increase throttle to Run 8 position.
6. Readjust slider on reference voltage setting resistor until voltmeter again reads 72 volts $\pm 1/2$ volt.
7. Tighten the slider in place.

8. Connect positive lead of the voltmeter to the positive terminal on front of the regulator.

9. Turn voltage adjusting rheostat RH clockwise until voltmeter indicates 74 volts. Lock into position by tightening locknut. Seal the locknut with red lacquer.

NOTE: Voltage adjusting rheostat may be set for other than the recommended 74 volts. Follow individual railroad policy regarding battery charging voltages.

10. Mount voltage regulator to high voltage cabinet.

PROCEDURE B

1. Connect positive lead of a DC voltmeter to the positive terminal on front of regulator. Connect the negative lead to the negative terminal.

CAUTION: Perform all necessary prestart procedures. Run engine to full throttle only as long as necessary to set regulator for 74 volts. Avoid continuous running of engine at full throttle with no load.

2. Start engine. Run engine at full throttle while performing Step 3 below.
3. Turn voltage adjusting rheostat RH clockwise until voltmeter indicates 74 volts.
4. Reduce throttle to Run 5 position.

NOTE: As the auxiliary generator and regulator resistors warm up the voltage will have a tendency to increase slightly. Allow the throttle to remain in Run 5 position until voltage stabilizes.

5. Increase throttle to Run 8 position.
6. Readjust voltage adjusting rheostat RH until voltmeter again reads 74 volts. Lock into position by tightening locknut. Seal the locknut with red lacquer.

NOTE: Voltage adjusting rheostat may be set for other than the recommended 74 volts. Follow individual railroad policy regarding battery charging voltages.

SERVICE DATA

EQUIPMENT LIST

Voltmeter - 0-150 DC	8218499
Test Light - 64 Volt	8279561
Battery Test Light - 3 Volt (Continuity Checker)	8293011
Voltohmmeter, Hickok Digital	8472576
Resistor - 40 Ohm, 200 Watt, 10%	
Capacitor - 0.1 Microfarad, 10 Volts AC	
Power Supply - 0-100 Volt DC, Minimum 4 Amperes	

MATERIAL LIST

Solder - 60% Tin, 40% Lead - 1.6 mm (1/16") dia., 2.3 kg (5 pound) Spool	8339154
Heat Sink Compound, Semiconductor - 141.8g (5 ounce) Tube	8346481
Conformal Coating, Urethane - .95 litre (1 quart)	8445687
Epoxy Adhesive Kit	8449045