



M AINTENANCE I NSTRUCTION

ELECTRIC IMMERSION HEATERS AND WATER CIRCULATING PUMP

DESCRIPTION

The Chromalox type electric immersion heater is an extra applied on locomotives and power units to keep engine water warm during layover periods or "off line" operations in cold weather.

The heater consists of a single heating element encased in an insulated tank and a thermostat to control the water temperature. Once the heater is put into operation, the water is thermostatically controlled turning the heater on or off as the water temperature reaches the settings of the thermostat.

While the heater is connected to its power source, the motor driving the circulating pump operates continuously regardless of the thermostat and existing temperature, thus giving a continuous circulation of water throughout the cooling system.

Before starting the heater make certain the engine water supply is adequate, any shutoff valves to the heater

are open, and all pet cocks are closed or the heater will be damaged.

Listed below are the part numbers of heaters currently used.

MAINTENANCE

The tank should be flushed out seasonally. The elements and inside of the tank should be cleaned as necessary depending upon the operating conditions. A visual inspection should be made of the switch and contact points at the start of the heating season, cleaning points as necessary.

The heating element and thermostat should be replaced if they ever become defective. It is not practical to attempt maintenance of these items.

WATER CIRCULATING PUMP

The water circulating pump used with the Chromalox immersion heater is an integral motor and centrifugal pump, with the motor and pump mounted on a single shaft.

CHROMALOX HEATERS - TYPE NWH

Part Number	Rating			Voltage			Thermostat		Application	
	KW	Wye	Delta	Phase	AC	DC	Range	Reset	Locomotive	Industrial
8228722	9	-	-	1	240	-	50°-250° F.	150° F.		×
8227519	15	15	11.25	3	<u>240</u> 480	-	50°-250° F.	150° F.		×
8228799	15	15	-	3	220	-	50°-250° F.	-		×
8238380	15	-	-	3	220	-	60°-250° F.	150° F.	×	
8261904	15	-	-	1	220	-	60°-250° F.	150° F.	×	
8237727	24	-	-	-	-	600	50°-250° F.	150° F.	×	
8250465	24	-	-	3	<u>240</u> 480	-	50°-250° F.	150° F.	×	

The motor portion is rated at 1/4 HP in either 110/220 volts 60 cycle single phase 1725 RPM, or 220/440 volts 60 cycle 3 phase. The pump portion is a single suction, single stage size 1 x 3/4 centrifugal type having a mechanical water seal.

Maintenance

No lubrication during operation is necessary on either the motor or the pump. However, after 12 months of actual operation, the motor and pump should be disassembled, cleaned and inspected. When reassembling, replace any defective parts.

If during the operating period, the pump should develop a water leak at the seal, it will be necessary to replace the seal. Replacement can be accomplished by referring to Fig. 1 and the following procedure.

Disassembly

1. Remove the complete pump and motor assembly and place on a suitable work bench.
2. Remove the four cap screws (12) securing pump casing (10) to the adapter cover plate (3) and remove the casing. Note position of gasket (6) between the casing (10) and plate (3). When reassembling, place a new gasket in this same position.
3. To remove the pump impeller (7), it will be necessary to first remove the plug (not shown) from the motor housing opposite the pump end and insert a screw driver into the slotted end of the shaft to prevent it from turning. Then by holding the shaft, turn the impeller nut (8) counterclockwise (facing the impeller) to remove the nut. The impeller is also removed by turning it counterclockwise while holding the shaft to prevent it from turning. Note that the lock washer (5) will be removed as the impeller is turned off the shaft.

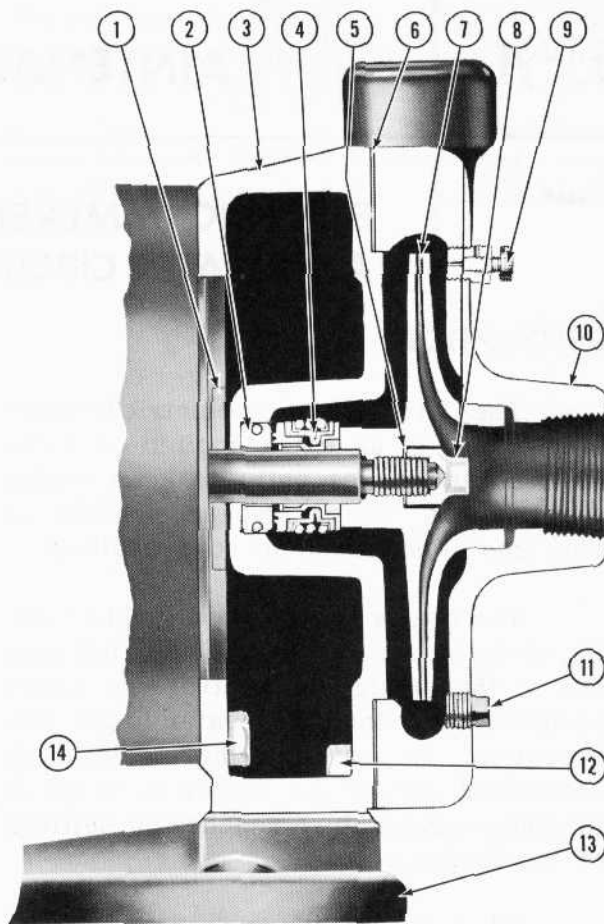

- | | |
|------------------------|-----------------|
| 1. Deflector | 8. Impeller Nut |
| 2. "O" Ring Seat | 9. Air Cock |
| 3. Adapter Cover Plate | 10. Casing |
| 4. Mechanical Seal | 11. Drain Plug |
| 5. Impeller Lockwasher | 12. Capscrew |
| 6. Gasket | 13. Base |
| 7. Impeller | 14. Capscrew |

Fig. 1 - Cutaway Of Pump

4. Remove the four cap screws (14) which hold the adapter cover plate to the motor and remove the assembly from the shaft.
- NOTE: The mechanical seal (4) may be bonded to the shaft making it necessary to steadily rock the adapter cover (3) while applying a pulling pressure on it to free the entire seal.
5. Remove the deflector (1) by sliding it off the shaft.
 6. Remove the "O" ring seat (2) from the cover plate by pressing it out.

Assembly

Before reassembling pump, make certain the cavity that holds the "O" ring seat is clean and free of dirt and rust. Then proceed as follows:

1. Make certain there is a $1/32$ " minimum radius (do not chamfer) on the edge of the cavity which holds the seat, see Fig. 2.

NOTE: When handling the seat and seal, take care not to damage the lapped sealing faces. These faces between the "O" ring and mechanical seal must be perfectly clean and free from marks when assembled to prevent leakage.

2. Oil the outer surface of the "O" ring (use light oil, not grease) and push the assembly into the cavity, seating it firmly and squarely.

NOTE: If it is not possible to insert seat with the fingers, press seat into the bore using a piece of tubing having a square cut end, Fig. 2.

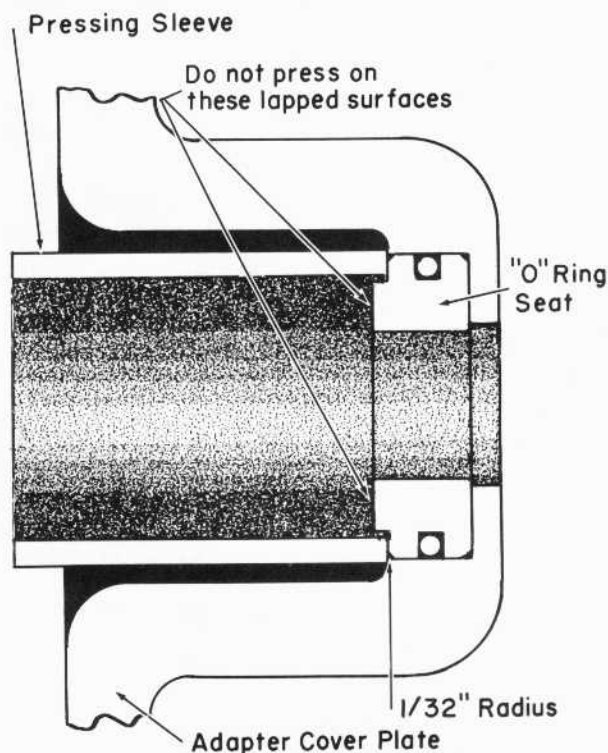

Fig. 2 - Installing "O" Ring Seat

3. Assemble the deflector to the shaft.
4. Assemble adapter cover plate carefully over the shaft and secure to the motor using the four cap screws previously removed.
5. Oil the shaft with light oil. The shaft should be clean and polished smooth. Slide seal assembly on shaft (washer end first) and seat firmly.

NOTE: A sleeve slightly larger than the shaft, as shown in Fig. 3, will facilitate this operation and prevent the rubber driving ring from pulling out of place. Make certain before assembly that all sealing faces are absolutely clean. Sealing faces should be oiled with clean light oil.

6. Hold the motor end of the shaft, as previously instructed, and apply the impeller to the shaft. Install lock washer and impeller locking nut.
7. Install new gasket to face of adapter cover making certain gasket is in the same position as one removed.

NOTE: The recommended thickness of the gasket is $.015$ " to $.020$ ". Do not use gaskets of greater thickness.

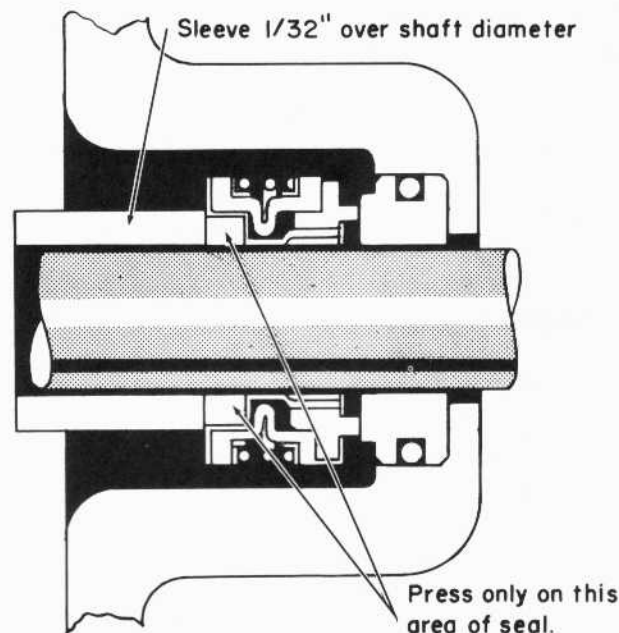

Fig. 3 - Installing Floating Seal

8. Apply outer casing in its proper location, securing in place with the four cap screws previously removed.

Before starting pump after reassembly, the pump casing and suction line must be filled with liquid. Use air cock,

located near top of pump casing, to bleed air out of pump and suction line. Never run pump with sealing face dry.

In some cases a short period of operation is required to clear up slight leakage.