



# MAINTENANCE INSTRUCTION

## TRACTION MOTOR DISASSEMBLY

### INTRODUCTION

General or "running" maintenance of traction motors is covered in Maintenance Instruction 3900. Also included in that bulletin is the procedure to be followed in dropping a truck from under a locomotive and for removing the traction motor from the truck.

After the traction motor is removed, the outside of the motor should be thoroughly cleaned to remove all dirt, oil and grease that may have accumulated while in service. This will provide cleaner working areas on the motor and will prevent dirt from entering the motor during disassembly. The importance of cleanliness cannot be overemphasized during all phases of motor work, particularly when handling such vital components as bearing assemblies.

Upon completion of motor exterior cleaning, the motor should be placed in its normal position on a suitable stand that will provide a convenient working height.

### TRACTION MOTOR DISASSEMBLY

The disassembly instructions given in this bulletin cover removal of traction motor end housings, armature and bearings from the stator assembly. Fig. 1 illustrates and identifies the component parts concerned.

After removing the commutator inspection covers, all brushes should be removed from brush holders. The commutator surface should then be protected by wrapping with a strip of paper measuring 1/16" x 7" x 54" which can be held in place by tape.

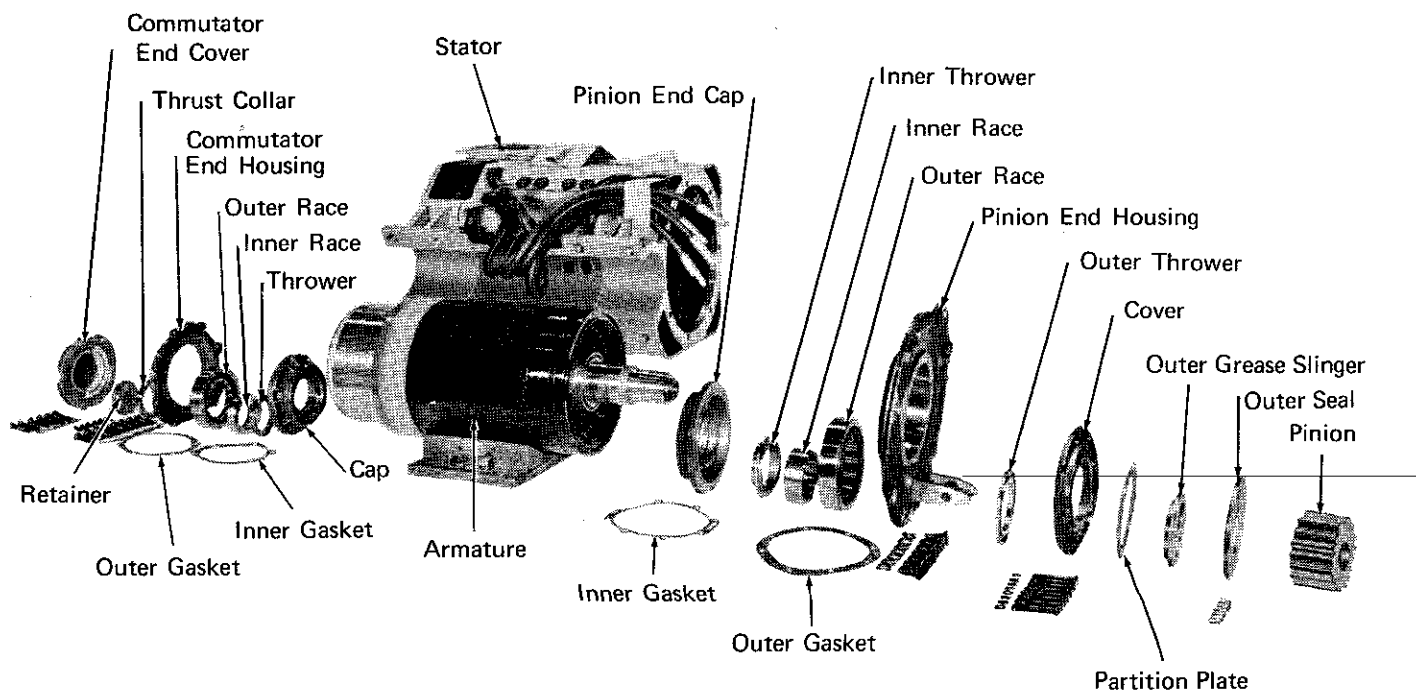

Fig. 1 — Exploded View Of Traction Motor

Removal of the motor pinion comes next. A detailed explanation of the removal procedure may be found by referring to Maintenance Instruction 3900.

## END HOUSING AND ARMATURE REMOVAL

Remove bolts holding the commutator end housing to stator frame. Using a 5/8"-11 NC tap, clean out the jack-out bolt holes in the motor frame. Insert three 5/8"-11 NC bolts in the jack-out holes.

Loosen pinion end housing bolts to the extent that they protrude from stator housing 3/4". These bolts are not to be removed at this time. Clean jack-out bolt holes in motor frame using a 7/8"-9 NC tap. Insert three 7/8"-9 NC bolts in the jack-out holes.

Using the jack-out bolts, simultaneously jack out both pinion end and commutator end housings, Fig. 2. Use care to drive housings evenly. If difficulty is experienced in starting the commutator end housing to move out of frame bore, insert three of the housing to frame bolts (previously removed) screwing sufficiently into the housing so that they may be tapped with a copper bar to help loosen the housing. As soon as the housing is loosened, remove the bolts and finish using the jack-out bolts. Continue to drive out both housings until the pinion end housing is against its bolts which have been loosened 3/4".

**CAUTION:** Do not force either housing ahead of the other. There is 1/8" to 3/16" play between the two bearing assemblies when assembled on the armature. When this clearance is taken up, the commutator end bearing thrust is taking the load. Also, caution must be used when driving the jack-out bolts to prevent damage to the bearings and housings. A few turns at a time on each bolt will keep the housings moving straight.

Remove the commutator end jack-out bolts. Apply lifting eye bolt 8067122 (or lifting fixture 8065527 for E series motors) to the pinion end of the shaft. Lift motor from stand and place in a vertical position, commutator end down, on frame stand 8064917, Fig. 3, which will support the frame in the proper position for removing armature.

Remove the pinion end housing bolts and raise armature slightly with the aid of a hoist, Fig. 3. Keep hoist hook centered over the armature shaft to prevent armature damage.

If housings are still held by the frame, tighten the pinion end jack-out bolts until housings are free. After releasing the housings from the frame, remove jack-out bolts and lift the armature out of the frame, Fig. 4, being careful to prevent contact between the armature and frame.

Apply armature turning plate 8067147 to the commutator end housing and insert bar through eye in plate, Fig. 5, using steel stand to pivot the armature while setting it into a saddle or rack. Do not set the armature on the commutator or bands. Support the armature on the core sections only.

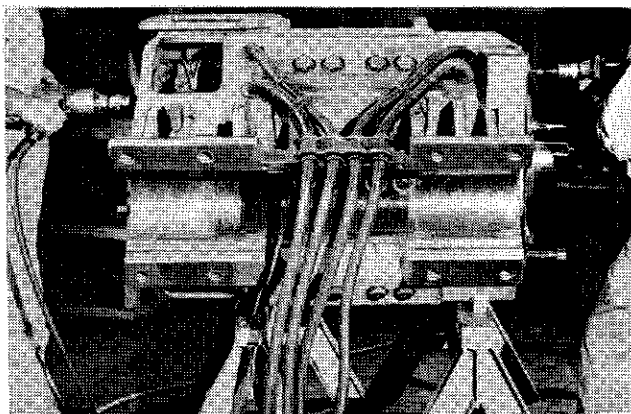

Fig. 2 — End Housing Removal

Remove the armature eye bolt from the pinion end housing, and the turning fixture from the commutator end housing.

### COMMUTATOR END BEARING REMOVAL

Remove the commutator bearing cover, the six bolts holding the retaining plate, and the retaining plate. Remove the commutator end housing with outer bearing race and rollers, and thrust collar, being careful not to cock or force the housing which could result in damaging the bearing.

Apply puller plate 8067130 and studs 8168606 to the commutator bearing cap, Fig. 6, and remove the cap, thrower and inner race being careful not to drop the race as it is pulled from the shaft.

CAUTION: Be sure pulling plate is pulling equally on the studs to prevent damaging the bearing cap.

If the collar and spacer, remaining on the shaft, are in good condition, do not remove.

Remove commutator end bearing outer race from the housing by completely supporting the face of the race, and pressing the housing off the race.

NOTE: A bearing press should be used to remove the bearings from the housings.

If bearing is to be inspected and retained for possible reuse, wrap complete bearing in clean, noncorrosive paper.

### PINION END BEARING REMOVAL

Remove the six bolts holding the oil seal to the pinion end bearing cover.

Insert studs 8168611 into the outer oil ring. Apply puller plate to studs and pull off outer oil seal, Fig. 7 (outer oil ring on models through early D77). If necessary, apply heat quickly and sparingly while pulling.

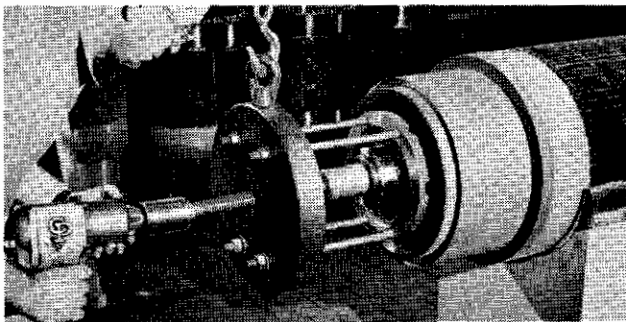

9929

Fig. 6 – Removing C.E. Cap Inner Race  
And Oil Thrower

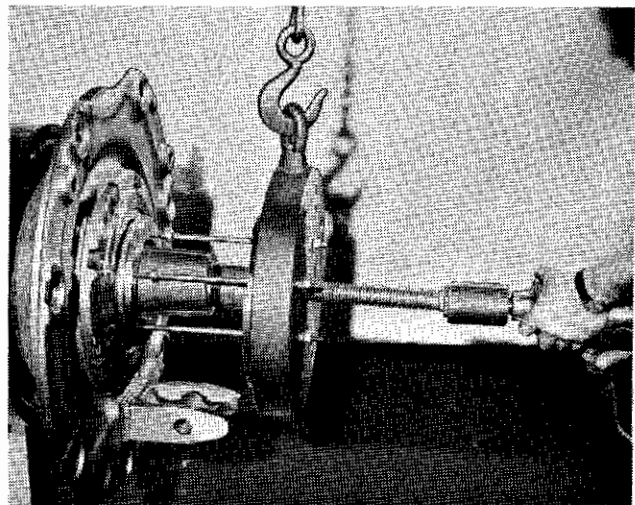

9930

Fig. 7 – Removing P.E. Outer Seal Ring

CAUTION: The outer oil seal should be removed before any attempt is made to pull the bearing assembly. Failure to remove the outer seal will result in damaging the bearing cap when pulling the assembly.

Remove the eight bearing cover bolts and apply puller to bearing cap using studs 8204436.

Line up puller plate and remove complete pinion end assembly. Support assembly with a hoist as shown in Fig. 8.

CAUTION: Make sure all studs are pulling equally to prevent damaging inner bearing cap.

With assembly free of shaft remove puller plate and studs. Leave one stud in assembly to prevent parts from falling. Remove assembly and press bearing out of housing.

If bearing is to be inspected and retained for possible reuse, wrap in noncorrosive paper.

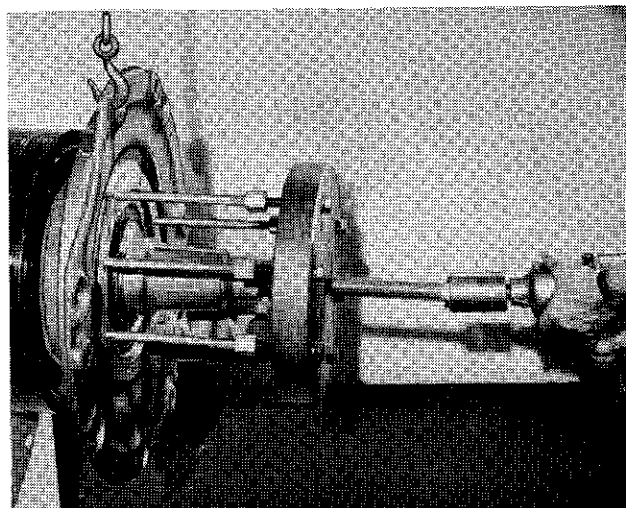

9928

Fig. 8 — Removing P.E. Bearing Assembly

**MAINTENANCE DATA**

Weights (Approximate)	
Motor with Pinion . . . . .	6,150 lbs.
Armature . . . . .	1,810 lbs.

**EQUIPMENT LIST**

	Part No.
Lifting Eye Bolt . . . . .	8067122
Lifting Fixture ("E" Motors Only) . . . . .	8065527
Frame Stand . . . . .	8064917
Armature Turning Plate . . . . .	8067147
Puller Plate . . . . .	8067130
Puller Plate Studs . . . . .	8168606
Puller Plate Studs . . . . .	8168611
Puller Plate Studs . . . . .	8204436