



MAINTENANCE INSTRUCTION

GENERAL MAINTENANCE—MODEL D37, D47, D57, D67, D75, AND D77 TRACTION MOTORS

DESCRIPTION

This bulletin covers general or "running" maintenance recommended for traction motors. It includes a procedure for removing a traction motor from a locomotive and the various inspections that should be made in such instances.

The D47 traction motor is almost identical to the preceding D37 model both in appearance and construction. The main difference is in the field coils which differ in copper size, insulation and resistance. Thus with the exception of the field

coils and aluminum baffles all other components in these motors are interchangeable. Following the D47, the model D57 was developed for use in both high speed and extremely heavy drag freight service. The general appearance of the D57 traction motor remains the same as the previous models, however, there were several manufacturing improvements including better insulation methods in the stator, application of a modified silicone varnish to the armature coils to greatly increase the heat resistance, use of a stainless steel non-magnetic square wire wedge to

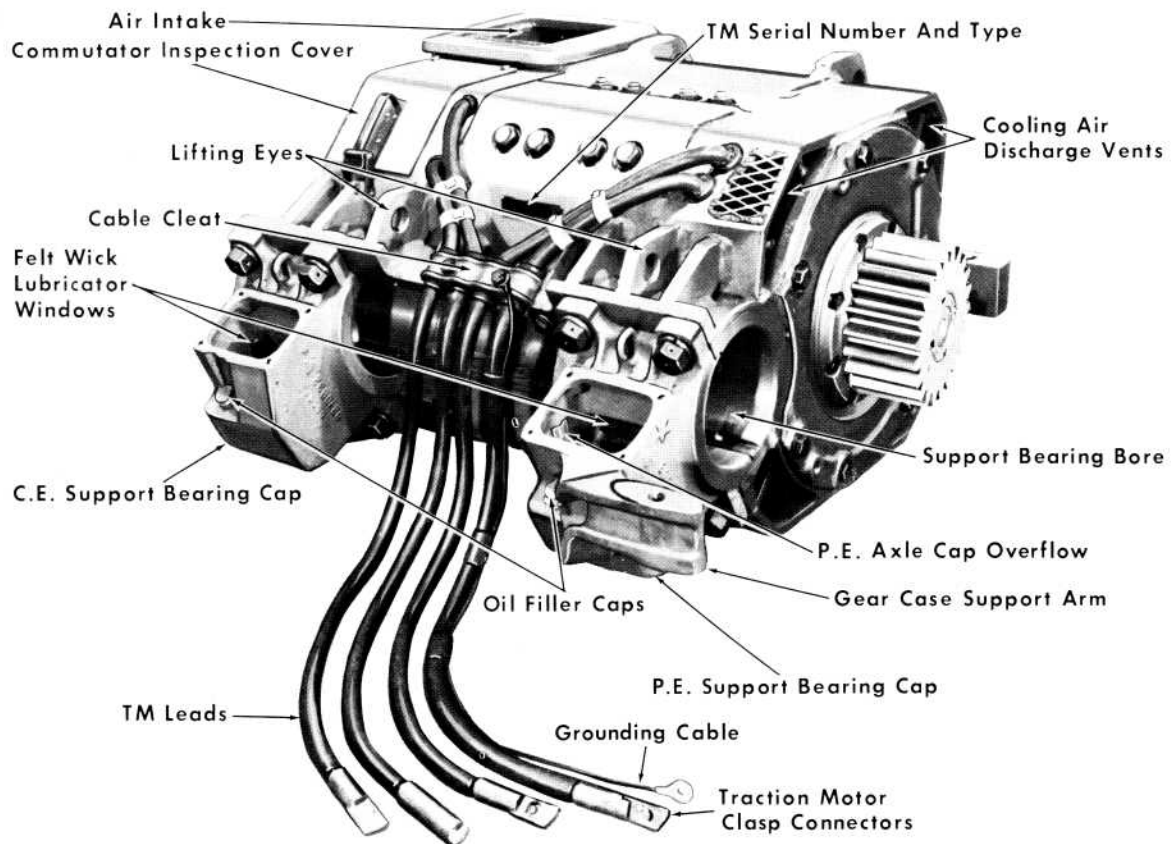

Fig. 1 — D77 Traction Motor

13845

*This bulletin is revised and supersedes previous issues of this number.

hold the two armature coil halves firmly within the core slot, improved seasoning of the commutator to raise the operating temperature by 50° C., and the use of constant pressure brush holders.

With the development of the new higher horsepower locomotives came the need for an even more powerful traction motor to succeed the D57. This new model, the D67, had many major improvements including new armature coil construction for temperature reduction and better moisture proofing; new type brush holders with longer brushes for extended brush life, the addition of a nylon grease retaining insert in the P.E. cover to prevent grease from purging, a new axle cap oil overflow arrangement to prevent overfilling, a manganese-steel wear plate to the motor nose support to obtain longer wear plate service life, a new high temperature non-silicone varnish and commutator end recabbling to reduce temperature of C.E. bearing under high speed, high current, dynamic braking.

The D77 motor, Fig. 1, is a product of the continuation of the never ending search for improvement. The four areas of major improvement are:

1. A thinner and stronger (both electrically and mechanically) armature insulation, which due to its decreased thickness provides room for an approximate 20% increase in copper.
2. A TIG welded joint between the armature coil and the commutator which insures a more positive electrical connection between the coils and commutator.
3. Three-wafer resilient pad brushes to provide improved commutation and increase brush life.
4. Nomex vee rings in the commutator which improves commutator stability and performance.

MAINTENANCE

Although these traction motors are designed to withstand the rugged service required of them, and are constructed of the finest materials available, like any machine they require a certain amount of maintenance. If the inspections and maintenance are carefully performed on a scheduled basis, the traction motors should provide the fine performance and long life built into them.

Reference should be made to the recommended maintenance intervals specified in the applicable Scheduled Maintenance Program. Particular attention should be given to each of the items covered under the following headings.

CLEANING

It is essential that the traction motor be kept as clean as possible, both on the inside and outside. Oil and grease soaked dust and dirt should not be allowed to accumulate as this can prove detrimental to insulation and motor performance in general.

Cleaning the outside of the motors can be done by the common method of using a steam jet at the same time the trucks, underframe and fuel tank are washed. If this method is used, the diesel engine must be running at about 450 RPM to force sufficient traction motor blower air through the motors to prevent water or moisture from entering.

The motor interior can be conveniently cleaned by blowing dust and dirt away with compressed air. A large volume of clean, dry compressed air should be used at a reasonable low pressure. Blasts of high pressure air should be avoided due to the possibility of loosening or damaging the protective coating on the insulation.

Clean, dry lintless cloths should be used in conjunction with the air to clean away

heavier deposits of dirt, and for wiping the brush holder insulators.

In cases where air and dry wiping cloths prove incapable of removing caked grease and dirt, a stiff brush, soft wood or fibre scrapers may be used. In severe cases it may be necessary to dampen a cloth in solvent such as Stoddards Solvent (A.S.T.M. D474-40) to loosen and remove imbedded deposits. Every precaution should be taken to keep the solvent off the commutator and copper parts as well as insulated coils and windings. Liquid solvents can destroy the protective coating on insulation causing it to peel or crack. Special care is also necessary to avoid subjecting the polyester glass insulated brush holder studs to alkaline type cleaning solutions.

CAUTION: Adequate ventilation and safety precautions are necessary when handling inflammable fluids such as Stoddards Solvent (flash point 115° F.).

COMMUTATOR BRUSH HOLDERS

All motors since the D57 have been equipped with constant pressure spring cell brush holders. The D67 and D77 motors use brush holder 8331061, which will accept a longer (2-3/8") brush. This longer brush reduces maintenance by extending the period between brush change-outs. The D37 and D47 model traction motor brush holders can be modified to use the constant pressure spring cell but if the longer brush is desired, 8331061 brush holder should be purchased. All early model traction motors rebuilt at the factory are equipped with the latest model brush holder.

Constant pressure type brush holder spring pressure is pre-set and can not be adjusted. However, new or replacement brush holder springs for coil spring type brush holders should be set for an initial

pressure of 8 to 10 lbs. as measured with a spring scale with the pressure spring lifted 1/8" above the top inside edge of the brush box, Fig. 2. Since new brush holder springs lose pressure in the first few weeks of operation due to aging, they should be checked frequently during this period and reset as necessary. After one adjustment they should retain their pressure.

The low spring pressure limit is 7 lbs., the minimum allowable on a completely worn brush. Thus spring pressure should always be set high enough (8 to 10 lbs.) to compensate for the loss of pressure that results as the brush wears.

Spring pressure may be adjusted by using the adjusting thimble and the alternate cotter pin holes in the spindle. Each half notch of adjustment will vary the spring pressure from 1-1/4 to 1-1/2 lbs.

The complete brush holder assembly, whether constant pressure type or coil spring type, should be checked for security of mounting and tightness of cable and brush shunt connections. Brush holders should be checked and adjusted if necessary to maintain a dimension of 1/8" to 3/16" between the bottom of the carbon-
way and the commutator surface, Fig. 6.

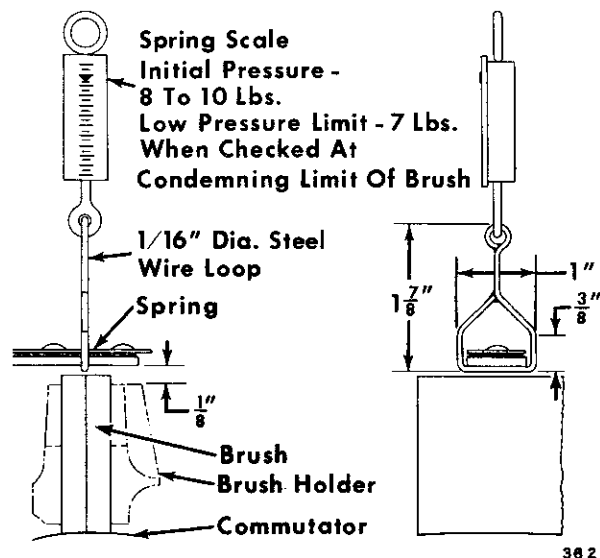

Fig. 2 — Measuring Coil Spring Pressure

NOTE: To insure proper tightness of brush holders and connections, the following dry torque values should be applied:

7/8"-9 brush holder block bolt
150 - 160 ft-lbs.

1/2"-13 brush holder cable to
brush holder bolt
70 - 75 ft-lbs.

5/16"-18 brush shunt screw
10 - 15 ft-lbs.

For ease of brush inspection and replacement it is suggested that the special tools designed for such purposes be used. See Service Tools Catalog for details.

INSULATORS

Particular attention should be paid to the insulators, making sure they are kept clean and free of defects. The polyester type brush holder studs are unusually resistant to flashover damage. If flashover damage does occur these insulators usually can be restored to satisfactory condition by simply polishing them with fine sandpaper. Polyester glass material should never be subjected to alkaline cleaning solutions.

Replacement polyester glass insulated studs are available as follows:

Standard size - 8159003. To be used when stud holes are within $.9935^{+}$ $-.0005$ ".

.002" Oversize - 8209068. For stud holes which have had a standard size stud pressed out.

.031" Oversize - 8209069. This should be used for extensively scored brush holders which have been reamed out to 1.0248^{+} $-.0005$ ".

The oversize studs may be readily identified by the figure 2 or 31 stamped on the end of the stud.

CONVERTING COIL SPRING BRUSH HOLDER TO CONSTANT PRESSURE BRUSH HOLDER

The old style D37 and D47 coil spring brush holders can be converted to a constant pressure type brush holder.

To prepare brush holder for conversion first dismantle it by removing the spindle, thimbles and springs and thoroughly clean and inspect the brush holder casting and insulator pins. Any defects that are found should be repaired. The conversion procedure is as follows:

1. Remove all raised numbers, letters, trade marks or bosses from the spring cell pockets which will not allow the spring cell to seat firmly. (Do not remove the oblong boss from the rear of brush holder casting 8310010 but be sure this surface is reasonably parallel with the casting surface.)
2. Insert the spindle in the spindle hole with the spindle pushed up against the top of the hole. Check the distance from the bottom of the spindle to the inside surface of the bottom web of the brush holder casting as shown in Fig. 3. If this dimension is more than .775" or if the hole is more than .020" oversize the hole must be plugged and relocated.
3. The rear tab of each new spring cell which is furnished with the conversion kit, is correctly adjusted for a 3/8" + 1/32"-0 offset as shown in Fig. 3. If spring cell is being reapplied, make certain that this dimension is correct before applying the cell to the brush holder.
4. Spindle 8081883 may be reused if in good condition but it is recommended that new type spindle 8296216 be used.
5. Place spring cell fingers in "cocked" position as shown in Fig. 3 when assembling cell to holder.

NOTE: To insure proper tightness of brush holders and connections, the following dry torque values should be applied:

7/8"-9 brush holder block bolt
150 - 160 ft-lbs.

1/2"-13 brush holder cable to
brush holder bolt
70 - 75 ft-lbs.

5/16"-18 brush shunt screw
10 - 15 ft-lbs.

For ease of brush inspection and replacement it is suggested that the special tools designed for such purposes be used. See Service Tools Catalog for details.

INSULATORS

Particular attention should be paid to the insulators, making sure they are kept clean and free of defects. The polyester type brush holder studs are unusually resistant to flashover damage. If flashover damage does occur these insulators usually can be restored to satisfactory condition by simply polishing them with fine sandpaper. Polyester glass material should never be subjected to alkaline cleaning solutions.

Replacement polyester glass insulated studs are available as follows:

Standard size - 8159003. To be used when stud holes are within $.9935^{+}$ $.0005^{+}$.

.002" Oversize - 8209068. For stud holes which have had a standard size stud pressed out.

.031" Oversize - 8209069. This should be used for extensively scored brush holders which have been reamed out to 1.0248^{+} $.0005^{+}$.

The oversize studs may be readily identified by the figure 2 or 31 stamped on the end of the stud.

CONVERTING COIL SPRING BRUSH HOLDER TO CONSTANT PRESSURE BRUSH HOLDER

The old style D37 and D47 coil spring brush holders can be converted to a constant pressure type brush holder.

To prepare brush holder for conversion first dismantle it by removing the spindle, thimbles and springs and thoroughly clean and inspect the brush holder casting and insulator pins. Any defects that are found should be repaired. The conversion procedure is as follows:

1. Remove all raised numbers, letters, trade marks or bosses from the spring cell pockets which will not allow the spring cell to seat firmly. (Do not remove the oblong boss from the rear of brush holder casting 8310010 but be sure this surface is reasonably parallel with the casting surface.)
2. Insert the spindle in the spindle hole with the spindle pushed up against the top of the hole. Check the distance from the bottom of the spindle to the inside surface of the bottom web of the brush holder casting as shown in Fig. 3. If this dimension is more than .775" or if the hole is more than .020" oversize the hole must be plugged and relocated.
3. The rear tab of each new spring cell which is furnished with the conversion kit, is correctly adjusted for a 3/8" + 1/32"-0 offset as shown in Fig. 3. If spring cell is being reapplied, make certain that this dimension is correct before applying the cell to the brush holder.
4. Spindle 8081883 may be reused if in good condition but it is recommended that new type spindle 8296216 be used.
5. Place spring cell fingers in "cocked" position as shown in Fig. 3 when assembling cell to holder.

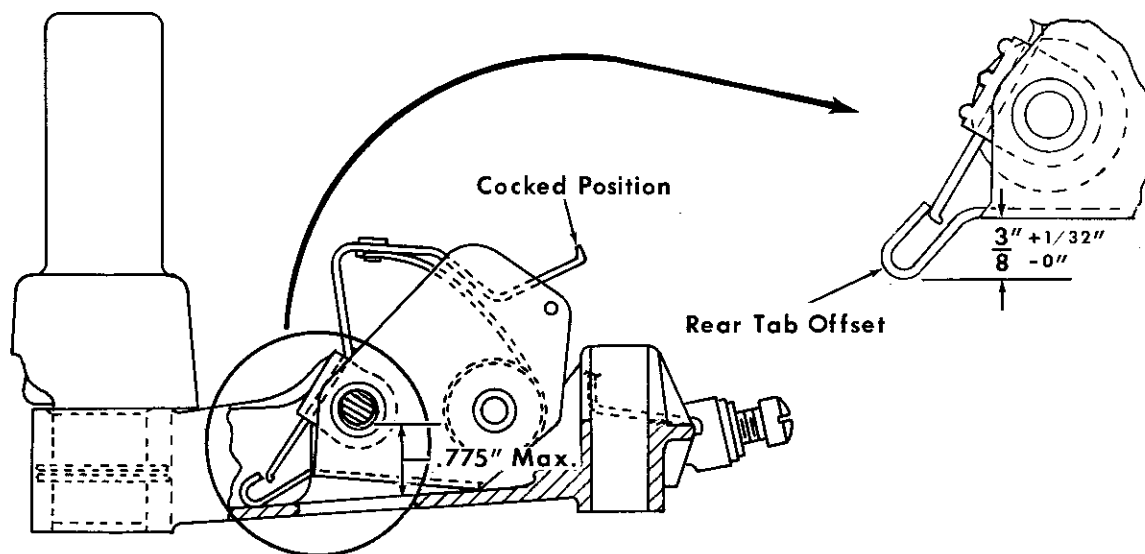

11936

Fig. 3 - Brush Holder And Cell Tolerances

6. Center a spring cell in right hand pocket and align with finger slot "A" as shown in Fig. 4.
7. Insert aligning tool 8305181 through spindle hole and spring cell being sure to add necessary washers at areas "B" and "C" as shown in Fig. 4. Check alignment of spring cell with finger slot "A" and if cell is out of line remove aligning tool and reassemble.
8. Use the same procedure with the center and left hand cells being sure to use as many washers in the lineup as possible. After each cell is assembled re-check its alignment with finger slot "A".
9. When all cells have been installed drive the aligning tool out of assembly with the spindle. Continue to drive the spindle through until it is centered in the brush holder.
10. Drill two 1/8" diameter holes at "D" Fig. 4. Insert groove pins furnished with the conversion kit and peen holes to hold pins. Check to see that the spring cell is tight in the brush holder.
11. After assembly, release spring cell fingers from cocked position to prevent handling damage and to prepare assembly for installation into motor.

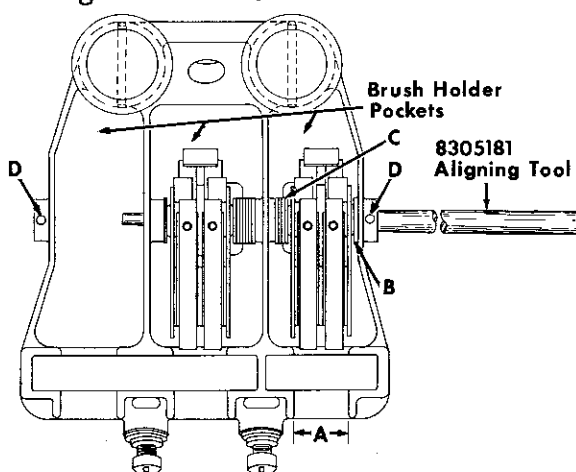

11937

Fig. 4 - Installing Constant Pressure Cell In Brush Holder

COMMUTATOR BRUSHES

The D75 and D77 motors are equipped with a three-wafer resilient pad brush which, as stated previously, improves commutation and increases brush life.

Three split type brushes are used in each of the four brush holder assemblies. The brushes should move freely in the brush holder and not be stuck with dirt. This can be checked by lifting the brush pressure spring and raising and lowering the brushes by hand. The new constant pressure brush holder springs must be raised by hand and placed in a "cocked" position,

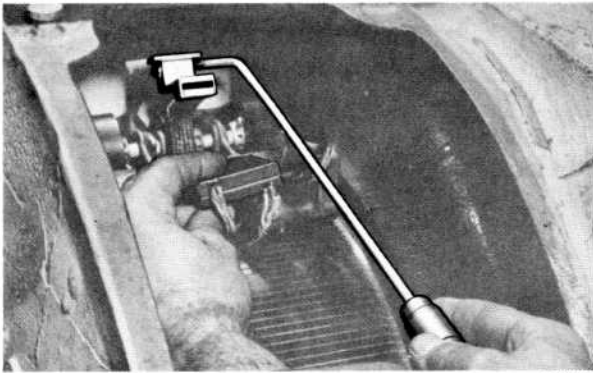

6 27 4

Fig. 5 — Brush Inspection

Fig. 3, but the older coil spring brush holder springs may be lifted with the use of lifter 8140869, as shown in Fig. 5. Carbonways must be smooth and brushes must fit closely so they will not chatter. Brush holders with carbonways worn enough to permit brush chatter should be replaced. Carefully lower the brush pressure spring over the brush to avoid snapping which is likely to cause the brush to be chipped.

Brushes should be carefully inspected and replaced if found chipped, broken, or worn to the condemning limit. This brush wear limit is easily determined by measuring the height of the brush pressure spring above the brush holder. If the spring is found to be $1/8$ " from contacting the brush holder as shown in Fig. 6, the brush should be replaced.

Brushes may be replaced individually as they wear to their condemning limits, rather than replacing all of them on a motor at one time. Replacement brushes

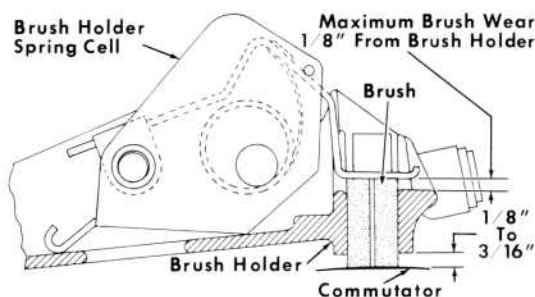

11969

Fig. 6 — Measuring Brush Wear

should, however, be of the same type and grade as the ones replaced since mixing brushes in the same motor can prove to be detrimental to successful operation.

Brush shunts should not be twisted or braided. The shunt connection to the brush holder should be securely made. Brushes should be replaced if found to have broken shunts, or where tamped shunt connection to the brush is loose.

When all new brushes are installed they should be sanded in so they will fit the contour of the commutator. This is done by placing a strip of fine sandpaper (#00 grade) on the commutator with the sand side up under the brush. In drawing the sandpaper under the brush, take care to follow the commutator surface to prevent rounding the edges of the brush.

COMMUTATOR

The commutator is a vital area on the traction motor and it should be kept in the best condition possible. Inspections should be made at frequent intervals to insure detection of surface faults before loss of service or expensive repairs become necessary. Such conditions as film stripping, bar burning, high or low bars, high mica or flat spots tend to become more serious with time. When found, the cause should be determined and corrected as soon as possible.

CREEPAGE SURFACES

The creepage area surfaces, shown in Fig. 7, should be kept in good condition.

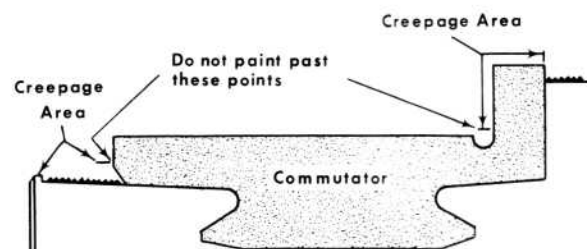

8782

Fig. 7 — Care Of Commutator Creepage Area

The areas should be cleaned frequently and repainted whenever necessary with red air drying insulating enamel 8061130. The procedure for repainting this surface is as follows:

1. Clean surfaces thoroughly with alcohol. Remove any trace of carbon.

NOTE: Red enamel can be applied over polyester surfaces if the surface has been damaged.

2. Using a clean brush, apply the red insulating enamel carefully to the creepage surfaces. Make as thin a coat as possible applying the enamel evenly leaving no dabs or overlapping areas.

The enamel will generally be of the proper consistency if the cover on the container has been kept tight. If thinning is necessary, use "Xylol" (8098692) sparingly.

3. Take care to avoid getting enamel into commutator slots or the relief at the bottom of the commutator neck.
4. Wait until enamel is dry before running motor.

NOTE: Do not apply enamel over carbonized or charred insulation. If the insulation can not be cleaned up satisfactorily as outlined above, the motor should be removed for more permanent repairs.

COMMUTATOR SURFACE CONDITIONS

Frayed brush shunts, highly polished brush to brush box contact surfaces, excessively worn brush pressure arms, broken pressure springs and rapid brush wear are indications of more than normal brush movement within the brush box and the cause should be determined. With few exceptions, the cause will be found to be commutator surface irregularities. The

constant monitoring of the brush problems mentioned above is the best and easiest method of determining when a commutator should be ground.

Road seasoning (repeated heating and cooling of the commutator), standstill burns, and overspeed can cause some slight bar movement to occur. This bar movement, depending on the amount, the number, and location with respect to each other, could trigger conditions detrimental to both the commutator and brushes. A commutator having certain irregularities in profile could operate satisfactorily at lower locomotive speeds, however, when operated at higher locomotive speeds, the problems of flashover, brush breakage, and frayed brush shunts may develop. A very rough commutator would have these same conditions occurring at lower locomotive speeds.

A rough commutator may or may not be readily apparent to the eye. Any question as to the condition of the surface can be answered with the use of a dial indicator attached to the motor so the plunger rides on the commutator surface. Be sure indicator is on one of the brush tracks. Rotate the armature slowly and carefully observe the readings. By merely noting the minimum and maximum readings, a true picture of the commutator surface will not be obtained. The .003" runout tolerance (for new or rebuild motors) is not applicable as a measurement of commutator irregularity as the problem of irregularity is not one of machining tolerances but of bar to bar movement. An example of this would be to have readings around the commutator that give a total variation of .002", however, hidden within the .002" variation are six low areas, each spanning one or more bars. This commutator would cause the brushes to bounce with resultant damage. A commutator having a total variation of .004" with the minimum and maximum readings 180°

apart is an acceptable commutator whereas the first example, .002" variation with several low areas, is not acceptable even though the total variation is much less. It is difficult to give a number value which would determine when a commutator should be ground. The values obtained by dial indicator must be evaluated with respect to the performance of the motor (brush problems, flashovers, etc.) and a certain amount of personal judgement must be used. A useful rule of thumb is that any condition worse than .002" in a six (6) bar span calls for grinding the commutator.

Resurfacing the commutator by turning in a lathe, or use of a grinder and grinder adapter, is the only correction recommended for a rough commutator. Hand stoning is definitely not recommended.

COMMUTATOR GRINDING

Minor commutator surface problems such as etching, roughness or slight burning can often be corrected by resurfacing using a grinding fixture. Refer to the Service Tools Catalog for information on grinder 8355891, supporting adapter, 8354239, for bolting to brush holder block, supporting adapter, 8354226, for bolting to bottom of motor frame, alignment bar 8210141 and associated parts needed for the job.

This grinding can be done on a motor in a truck while under the locomotive by using the following method:

1. Block all wheels on truck at opposite end of locomotive to one having traction motor commutator ground.
2. If the axle of the wheel set driven by the motor having its commutator ground is equipped with roller journal boxes, proceed as follows to raise the desired wheel set:

- a. Apply suitable wooden or steel blocks under the two journal boxes between the pedestal tie bar and the journal box on the wheel set to be raised. These blocks will hold the axle in its original position and eliminate unnecessary raising when the motor is being run. Next apply jacks under the locomotive frame at jacking pads provided and raise one end of the locomotive with truck so the desired wheels are just above the rails.

- b. An alternate method of raising a pair of wheels is to remove the weight of the locomotive from the truck with jacks, then raise the desired wheel set by placing jacks directly under the journal boxes.

3. If the axle of the wheel set driven by the motor having its commutator ground is equipped with friction type journal boxes proceed as follows to raise the desired wheel set:

- a. Apply suitable wooden or steel blocks under the two journal boxes between the pedestal tie bar and journal box on the wheel set to be raised. Then apply jacks under the locomotive frame at jacking pads provided and raise one end of the locomotive with truck so that the desired wheels are just above the rails. Next jack CAREFULLY under traction motor axle bearings until they take the weight of the axle and wheels only. Block all raised parts with exception of wheel set being worked on.

4. Disconnect all four traction motor leads of the motor to be worked on, and tag leads so they can be reconnected in their original position. Connect the "A" and the "FF" leads of

the traction motor together. Connect the "AA" traction motor lead to the positive (+) lead of a DC welding machine (or other source of DC electrical energy) and "F" traction motor lead to the negative lead of a DC welding machine. This connection will turn the motor counterclockwise when looking at the commutator end.

NOTE: Commutators can be ground by utilizing locomotive power. Contact EMD Service Department for details.

5. When using brush holder block mounted grinder remove the top commutator inspection cover, remove the top brush holder assembly and the brushes from one adjacent brush holder. Do not remove the other two sets of brushes as they are needed for motoring the armature. The supporting adapter is now mounted in place of the removed brush holder assembly, Fig. 8a. Clamp adapter securely in place by the brush holder blocks.

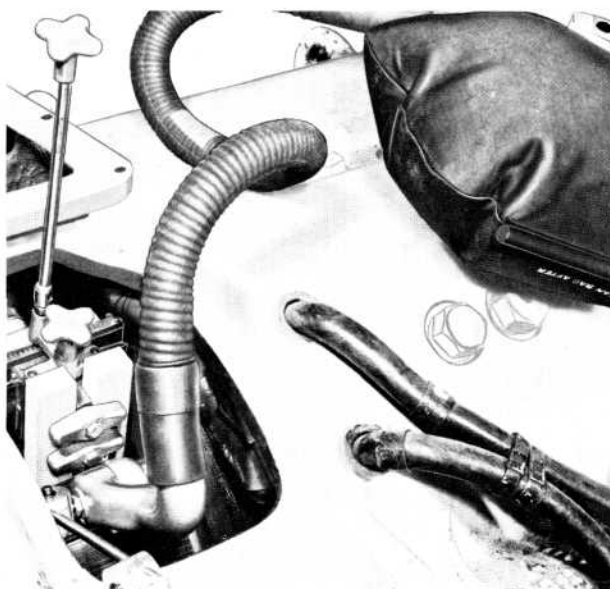

(a) Brush Holder Mounted

6. When using frame mounted grinder remove the bottom inspection cover by removing six 1/2"-3 hexhead bolts. It is not necessary to remove any brush holders but the brushes must be removed from the bottom brush holder to prevent the possibility of the shunts grounding to the grinder support bracket. Install the supporting adapter, Fig. 8b, and align the grinder mounting pads parallel to the commutator.

7. Install the grinder on the supporting adapter as shown in Fig. 8a. Set the grinder so that it clears the commutator and that the cross feed will run parallel to the commutator bars. Use alignment bar for this purpose.

8. Remove alignment bar and install grinding stones making sure they are seated squarely on the commutator. Using the radial feed, pull stones away from the commutator. Install vacuum attachment to keep copper dust out of the motor during grinding process.

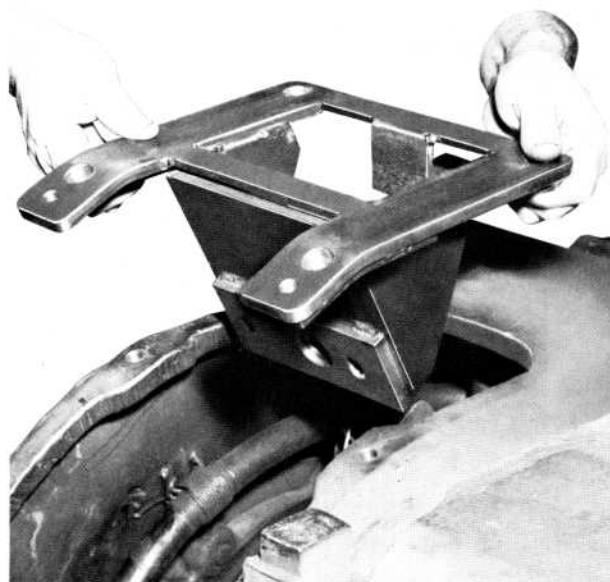

(b) Frame Mounted

Fig. 8 — Commutator Grinder Application

9. Start the electric welding machine and adjust voltage to run the motor armature at approximately 1000-1500 RPM.
10. Feed grinding stones into commutator slowly until a light contact is made, then feed stones across commutator. Repeat as necessary, then finish by running stones across commutator several times without feeding radially.
11. After grinding and restoring the commutator surface to a satisfactory condition, remove the grinding equipment. Using a wire hand brush, deburr the edges of the commutator bars to remove any copper slivers that may have occurred during grinding. Draw the brush across the commutator in the direction of the bars.
12. When the depth of the mica undercut between the commutator bars is less than $3/64$ ", use commutator slot file, 8238905, as shown in Fig. 9, to undercut the mica to the proper depth. Do not exceed the mica undercut maximum depth of $5/64$ ".

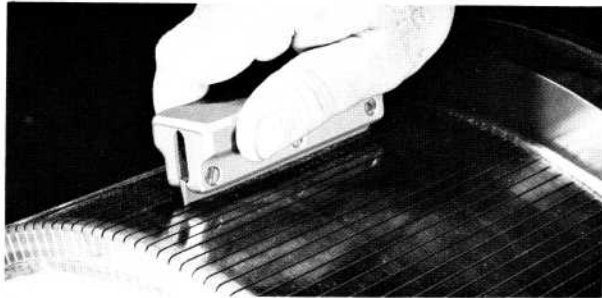

Fig. 9 — Cleaning Commutator Slots

13. Use chalk stone for final clean up of commutator. Do not use emery cloth or sandpaper for this purpose. Lubricant should never be used on commutators as brushes have enough graphite to supply their own lubrication.
14. Thoroughly clean the motor to remove all copper dust and slivers. This can

be done by running the motor and directing compressed air on the face of the commutator. Wipe dirt and copper dust away using clean cloths. Carefully inspect the cleaning job and particularly the slots between the commutator bars to see that all traces of undesired copper have been removed.

15. Restore motor for operation after grinding by replacing brush holder assembly and/or renew brushes removed during grinding operation. Reconnect cables and install inspection cover. Check motor for proper rotation before returning locomotive to service.

NOTE: If the commutator has been damaged to such an extent that the grinding process outlined proves ineffective, the motor will have to be removed and the armature turned in a lathe.

ARMATURE BEARINGS

NOISE TEST

Each time a traction motor is removed from a locomotive truck it should be motored so that a noise check can be made for faulty armature bearings. Performing this test will serve as a means of detecting faulty bearings thus preventing such a motor from operating in service where it would likely result in a road failure.

The power source and cable connections for this test are the same as described previously for motoring the armature during commutator grinding. The armature speed should be brought up to about 1500 RPM and then the power shut off to allow the armature to coast to a standstill. Carefully listen and try to determine the source of any noise that might be considered unusual. Experience and comparison with other motors will help distinguish a faulty bearing from a normal one.

SEALED GREASE LUBRICATED BEARINGS

Unless otherwise specified by the customer, all traction motors are manufactured with sealed grease lubricated armature bearings. A specific type of grease is used. The amount and method by which it is applied is carefully controlled. Effective with D67 traction motor, and available for older models, is a sectionalized nylon insert installed in the pinion end bearing cover to prevent an excessive amount of grease from being moved into the rollers by slumping action caused by vibration. This reduces "churning" of the grease which in time causes the grease fibers to become soft and susceptible to purging. These factors should permit the motor to be operated without further bearing attention to the motor overhaul period specified in the applicable Scheduled Maintenance Program. For information on repacking these bearings refer to Maintenance Instruction 6850.

OIL LUBRICATED BEARINGS

On special order, all models of traction motors can be equipped with oil lubricated armature bearings. Such motors may be readily identified by the oil filling tube applied to the bearing covers. This tube has a spring loaded button valve at the opening to protect the armature bearings from dirt and moisture encountered in service.

The interval at which oil should be added to such bearings is outlined in the applicable Scheduled Maintenance Program. The specific type of oil to be used is listed in Maintenance Instruction 1756. Specially designed oil dispenser 8191382 should be used as recommended in the Service Tools Catalog. A meter on this dispenser accurately measures the ounces of lubricant added. This is important

since over lubrication will result in the excess oil working out of the bearing and getting into the motor. The meter will not register when air is pumped.

GEAR CASE AND GEARS

The gear case houses the traction motor pinion and mating axle gear protecting them from dirt or damage and carries the gear lubricant. The cases are made of two close fitting halves and feature offset seals to provide complete contact and closure. Removable gutters over each seal retainer, and grease deflectors, divert the flow of grease away from seal surfaces.

The inspection opening and grease filler cap is located at the axle end of the upper and lower halves of the case. This makes it more convenient for inspecting gears, checking and adding lubricant.

The caps are sealed by mating machined surfaces without the need of gaskets. A leaf spring assembled to the top of the filler cap maintains pressure against the flanges around the gear case filler opening, assuring a positive sealing action. The current filler caps may be easily removed or applied by depressing the leaf spring using tool 8250241 as shown in Fig. 10.

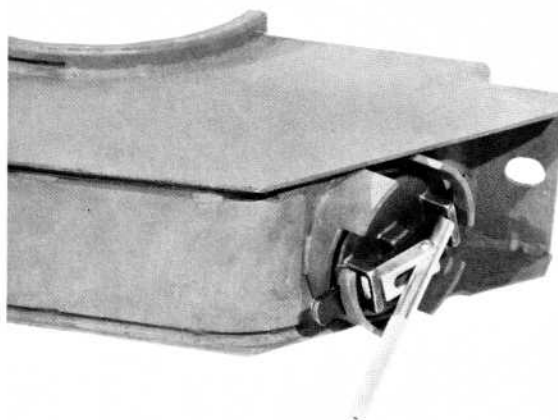

8892

Fig. 10 — Filling Cap Removal Tool

The current gear case also features unit type felt seals inserted into the channels at the axle and pinion openings. The seals are held in place by small pieces of metal at one end of the channels next to the inside of the case and are designed to prevent the seal from turning. This will tend to prevent the excessive loss of lubricant that occurred when the previous type felt seals would move in the channels due to the turning forces imposed on them.

Older style gear cases can be modified to use the unit seal by first removing the old felt and cement from the channels. Then seven small pieces of metal are welded, at the top and bottom, opposite to each other at one end of the channel next to the inside of the case as shown in Fig. 11. Gasket compound or cement is not required for unit seals thus the previous task of cleaning out channels during seal replacement is no longer necessary. It is then a simple matter to replace worn unit seals with new ones.

NOTE: The preceding gear case improvement plus the installation of the new style removable gutters are explained in detail in Maintenance Instruction 9532.

LUBRICATION

Inspection of gear cases should include checking for lubricant leaks. Excess lubricant will be discharged through the drain slot of the traction motor grease seal during the first few thousand miles of operation and is no cause for concern. Prolonged leakage at any other point, however, should be corrected.

Refer to the applicable Scheduled Maintenance Program for the recommended interval of gear case inspection and the type of lubricant to be used. Frequent gear case grease level inspections should be made using such intervals as a guide until the maximum mileage between lubrication intervals can be determined for the specific type of service encountered.

The need for lubricant can be readily determined by observing the condition of the gear teeth through the gear case inspection opening. Gear teeth appearing dry or having bright spots indicates that the lubricant level should be checked and that grease may have to be added. The table below indicates minimum lubricant levels for the various gear cases. Two pounds of recommended lubricant should be added when such inspections indicate the need.

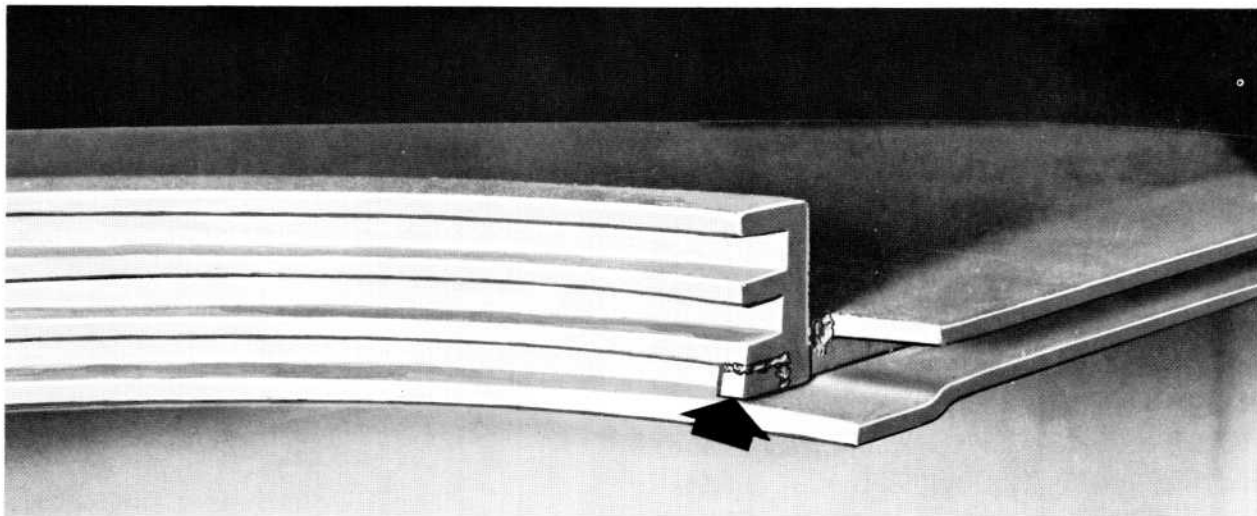

9 10 1

Fig. 11 — Gear Case Modification

Measurements of lubricant level should be made after a locomotive comes in from a run and is allowed to stand without moving for at least one-half to one hour. This will allow time for the grease to drain to the bottom of the case and cool. This time interval should remain consistent each time a level measurement is taken since variations will result in considerable differences.

Approximate Minimum Operating Levels

Medium Gear Case	Small Gear Case	Large Gear Case
62/15 - 11/16"	57/20 - 5/8"	65/12 - 9/16"
61/16 - 7/8"	56/21 - 13/16"	
60/17 - 1-1/8"	55/22 - 1"	
59/18 - 1-3/8"	52/25 - 1-11/16"	
58/19 - 1-5/8"		
57/20 - 1-13/16"		
56/21 - 1-15/16"		

GEAR CASE INSPECTION WHEN REMOVED

After removal, thoroughly clean gear case of all dirt and grease by immersing in hot water solution of caustic. Never remove grease by burning as this may distort the gear case to the extent that it will not fit properly when installed and grease leakage will occur. When clean and dry, repaint gear case using buff primer 8176057.

Felt seals should always be replaced whenever a gear case is removed as failure to do so may result in serious lubricant loss while in operation and possible damage to the gears. The seal change procedure is as follows:

1. On current style or modified gear cases having unit seals, simply remove and discard old seals and apply complete new unit seal assembly. There is no need to clean out channels or apply cement to new seals.

With older gear cases, it is necessary to clean out the channels before replacing seals. After this is done, carefully apply a thin coat of gasket

compound (Permatex) to the three surfaces of each seal retainer groove. Too much compound should be avoided as it will prevent seating of seal to correct diameter at all points, thus affecting the function of the seal. After installing seals, cut the ends parallel to and 1/16" above the ends of the seal retainers. Allow time for gasket compound to dry before applying gear case.

2. Check to make sure the drain slot between seals is open to ensure against contamination of support bearing oil with gear lubricant. Grease entering the support bearing would clog and glaze the lubricator wick making it inoperative.
3. Apply a generous quantity of lubricating oil to the felt seals.
4. Assemble the gear case to the truck assembly making sure the bolts and safety straps are properly applied and secured. Tighten the bolts and torque to approximately 450 ft-lbs. Failure to properly tighten the bolts will result in excess wear due to vibration on the supporting arms located on the axle cap and pinion end bearing housing.

NOTE: If the case is assembled to supports worn beyond the minimum limit of 3-31/32", the felt seals will become distorted and allow leakage around the axle and pinion openings.

5. Charge gear case with ten pounds of recommended lubricant. It is important that only the recommended lubricant (see Maintenance Instruction 1756) be used since substitutes often have poor oxidation stability and tend to solidify in extended service. Mixing of gear lubricants should also be avoided due to similar possibilities.

- After an initial trip, check gear case condition and lubricant level adding a two pound quantity if required. Thereafter, inspections should be made at intervals specified in the applicable Scheduled Maintenance Program.

MOTOR SUPPORT BEARINGS

The traction motor has three suspension points in the truck. Two are provided by the support bearings which connect one side of the traction motor to the wheel axle. The third point is provided by two lugs on the motor frame that contact the top and bottom of the nose support assembly on the truck frame. This nose suspension thus arrests the upward or downward movement of the motor depending on direction of rotation when power is supplied.

The support bearings are of the split type and "hour glass" design. A half of each bearing assembly is inserted in the motor frame while the mating half is installed in the support bearing cap. Both halves are machined together and are identified by a serial number. The bearings are thus matched and must be kept together

and installed in sets. The commutator end and pinion end bearing assemblies are interchangeable.

SUPPORT BEARING LUBRICATION

Lubrication of traction motor support bearings is provided by felt wicks inserted in the oil reservoir in each bearing cap. Six wicks are used in each assembly and a spring loading arrangement keeps the wicks firmly in contact with the wheel axle through an opening in the bearing.

The oil level in the support bearing cap should be checked at intervals specified in the applicable Scheduled Maintenance Program. The level is determined by inserting a clean steel rule or rod properly marked, into the oil filler hole. Accurate measurements can be obtained only if the rule or rod is inserted parallel to the pipe as shown in Fig. 12.

A narrow window traction motor axle cap and support bearing arrangement has been in use since the late D47 traction motor. The narrow window provides increased oil capacity and larger bearing surface as well as an improved wick

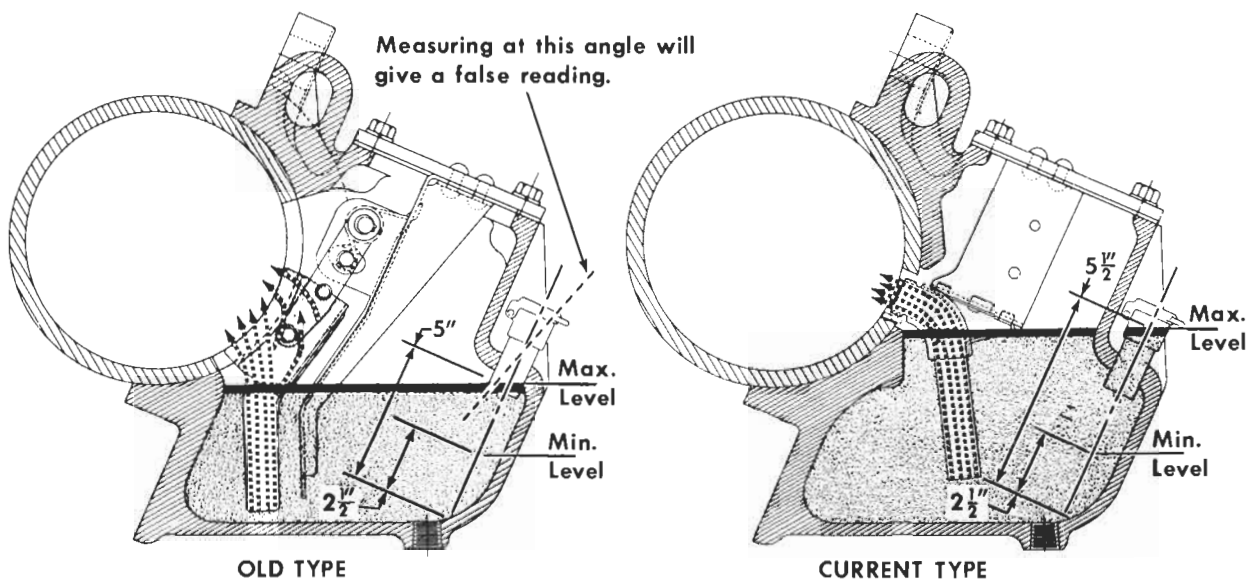

Fig. 12 — Motor Support Bearing Oil Level

14150

assemblies and 5 pound weight for used assemblies. The narrow window support bearing lubricator spring should be able to raise a 2 pound weight placed on the contact surface after the wick is depressed. The test should be made with the wick saturated with car oil and with all sliding parts clean and lubricated.

6. All early style flat or constant pressure type narrow window support bearing wick lubricator springs should be inspected for cracks near rivet point. If any defective or cracked springs are found, the assembly should be replaced with the torsion spring conversion kit. See Parts Catalog for correct replacement part numbers for lubricator wicks and torsion spring conversion kits.

Before returning used wicks to service they should be impregnated with oil. New wicks have been oil impregnated at the factory and are ready for use without further preparation unless they have become dry due to length of storage. If this

is the case, then they should also be soaked before using.

Using lubricating oil specified in Maintenance Instruction 1756, soak wicks for a minimum of 20 minutes at room temperature or 10 minutes if oil can be heated to 160° F. Wicks should not be allowed to touch bottom of container when soaking in heated tank. After thorough soaking, allow to drain for about 10 minutes to facilitate handling and installation. Use care to keep wicks clean while handling.

If there is evidence that water has entered the wicks, the moisture should be removed by submerging in oil heated to 220° F. for 8 hours. After such treatment, allow to cool, while still submerged until room temperature is reached. The wick assembly should then be removed and allowed to drain for 24 hours before use.

SUPPORT BEARING WEAR LIMITS

The support bearings should be checked for radial and lateral clearance to make sure they do not exceed the wear limits shown in Fig. 14.

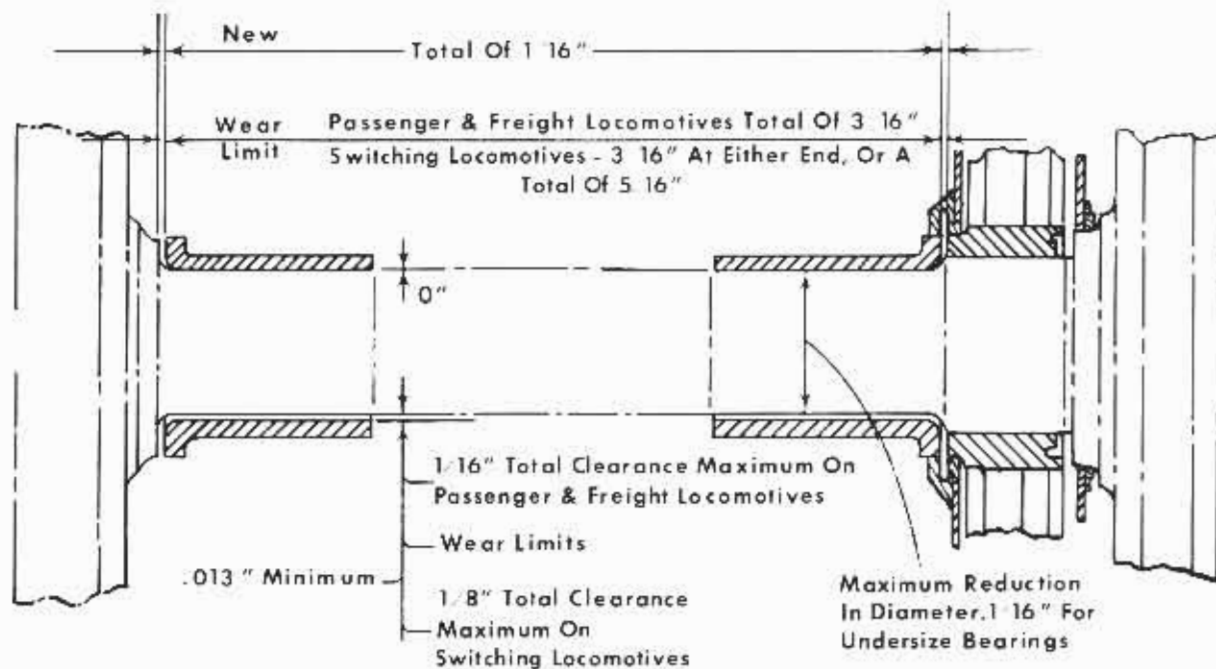

3969 B

Fig. 14 — Support Bearing Clearance

lubricator, Fig. 12. Since the D67 motor, all motors have had an additional overflow arrangement at the P.E. axle cap to reduce migration of excess axle cap oil into the gear case. It includes a 3/8" hole through the side of the pinion end cap which allows the excess oil to drain from the cap when it is filled beyond the recommended 5-1/2" level. The hole is covered by a baffle inside the cap (Fig. 1) to prevent splash loss and a cover on the outside of the cap to prevent road dirt and water from entering the axle cap.

The lubricating oil level should be maintained between the limits of 5" maximum and 2-1/2" minimum for the wide window bearing used on early D47 and previous model motors. The maximum level for the narrow window bearing used in the D57 motor is 6-1/2" and the minimum level is 2-1/2". The maximum level of the D67 and later models is 5-1/2" at the P.E. since the level is controlled by the overflow drain hole which allows the oil to run out if it is over the maximum level.

Refer to Maintenance Instruction 1756 for recommendations on the type of lubricating oil specified for support bearings, adding as needed to maintain desired level.

FELT WICK LUBRICATORS

Felt wick lubricators should be carefully cleaned and inspected very time the support bearing caps are removed. Cleaning is done by using standard car oil at a temperature between 120° and 160° F. and a stiff bristled brush. The use of a scraper or wire bristle brush is not recommended.

After cleaning, the felt wick assemblies should be inspected to determine if they are in a satisfactory condition for continued service. The following points should be observed:

1. Wick pads should be discarded if they have hardened, glazed or burned con-

tact surfaces. Normal service tends to pack the upper portion of the pad yet this is not cause for rejection unless the pads have hardened to the extent that they no longer absorb oil readily. This may be checked by applying oil and noting how quickly it is absorbed. If a pool of oil remains on the surface or is absorbed slowly, the wick should be replaced.

2. The wick pad contact surfaces should be free of major irregularities. Slight depressions are permissible provided they do not extend the full length of any individual wick.

Pad contact surface depressions may be checked with a straight edge. If any are found to exceed 1/8" or if a regular "saw tooth" pattern is observed, the wick should be discarded.

3. The narrow window type wick should be replaced when contact surface has worn down to within 1/4" of the metal wick carrier or when the felts have elongated the rivet holes and are loose in the wick carrier.
4. Visually inspect the metal wick carrier assembly for warping, distortion or cracks which are causes for rejection. Check pinholes and pins for wear and replace parts if worn more than .012" over new assembly.
5. Check wide window support bearing lubricator spring pressure by placing a weight on the wick as shown in Fig. 13. Use a 7 pound weight for new

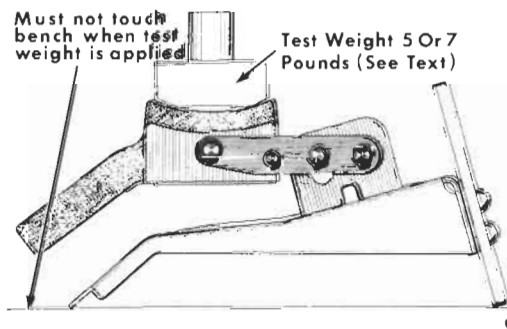

6728

Fig. 13 — Testing Wick Lubricator Springs

Radial bearing to axle clearance is measured by removing the felt wick lubricator and inserting a narrow feeler gauge between the unloaded area of the bearing and the axle.

The bearings should be replaced in sets when the wear limits are reached.

REMOVING MOTOR SUPPORT BEARINGS

1. Run the locomotive over a pit if one is available, or locate it in the best place for working on the underside of the axle.
2. If the bearing to be removed is on the gear side, it will be necessary to remove the gear case safety straps and drop the lower half of the gear case.
3. If the bearing to be removed is on the commutator end, remove both halves of the dust guard.
4. Remove felt wick lubricator assembly from support bearing cap.
5. Take out the four support bearing cap bolts.
6. Remove the support bearing cap. If the cap sticks, it can be loosened by tapping the cap, first one side and then the other. Care should be taken to see that the cap is properly supported by a helper or backed up by blocking when it is being loosened, otherwise the cap may drop suddenly causing personal injury or a broken cap, or both.
7. Remove the axle shield and the lower half of the support bearing. It will not be necessary to loosen the other support bearing cap in order to free the axle shield.
8. To remove the upper half of the bearing, jack the motor frame high enough to relieve the weight on the bearing

and to free it from the key. Then revolve the upper half around the axle until it can be slipped off. If bearing sticks in the frame, it can be knocked loose by driving down on the flange with a hammer and wooden block.

SUPPORT BEARING INSPECTION

Bearing shells should be carefully inspected and replaced or returned to service depending on the following conditions.

1. Replace bearings showing any kind of shelling, cracks or signs of fatigue.
2. Replace bearings found to have the babbitt loosening from the backing or babbitt worn through to the backing.
3. Bearings showing signs of overheating should be replaced.
4. Bearings having badly grooved or undercut flanges should be replaced.
5. Scratches in the babbitt or brass will not condemn a bearing providing that they can be cleaned up to remove any projecting burrs or edges.
6. If small foreign particles are found imbedded in the babbitt and can satisfactorily be removed, the bearing may be returned to service.

Before replacing bearings that show signs of having been overheated, the cause should be determined and corrected. The following points should be checked:

1. Insufficient lubricating oil in the support bearing cap.
2. Use of improper or contaminated lubricating oil.
3. Insufficient bearing clearance.

4. Misalignment of bearing shells.
5. Dirt or other foreign substances working into the bearing.
6. Wick lubricator surface fouled with dirt, or glazed.
7. Damaged or improperly operating wick lubricator assembly.

In the event that the bearing has run extremely hot, it is likely that the axle bores have been distorted and the traction motor heated sufficiently to cause damage to the frame, bearings and field windings. Suspicion of any of these items having occurred will necessitate removal of the motor for thorough inspection. Particular attention should be paid the motor armature bearings as the heat may have dissipated the grease. Traction motor removal is covered later in this bulletin as is the use of a mandrel for checking axle bore alignment.

REPLACEMENT SUPPORT BEARINGS

To accommodate worn or undersize axles, motor support bearings are available with 1/32", 1/16" and 1/8" undersize bores. These bearings have standard size flanges. Bearings are also available with standard bores and 1/32" or 1/16" oversize flange thickness which may be used to keep within the lateral measurements specified in this bulletin. To prevent inadvertently applying such bearings, the flanges are stamped with the oversize designation and painted red. An oversize bearing may be mixed on one axle with a standard or another oversize bearing in order to obtain the proper lateral dimension.

SUPPORT BEARING CAPS

The support bearing caps, Fig. 15, are machined and line bored to size when mounted on the traction motor with a .018" shim inserted between the cap and

motor frame. When the motor is mounted in a truck, a .010" shim is used in fastening the cap to the frame thus giving a .008" clamp fit or squeeze to the axle bearing shells.

Line boring of the caps to the motor frame is necessary to secure the accuracy of bearing fit required. The caps are not interchangeable with each other on a given motor or with caps of other motors. To insure that they are matched to the proper motor and location, they are stamped with a serial number matching the motor frame number.

Support bearing caps that have been removed should be thoroughly washed in a suitable solvent. After cleaning and drying, the cap may be tested for leaks by painting the outside with chalk dust mixed with water. When dry, fill with kerosene and allow to stand for one hour, then observe for leaks.

INSTALLING MOTOR SUPPORT BEARINGS

1. Make certain all parts are clean, particularly the bearing shells, seats, axles and caps.

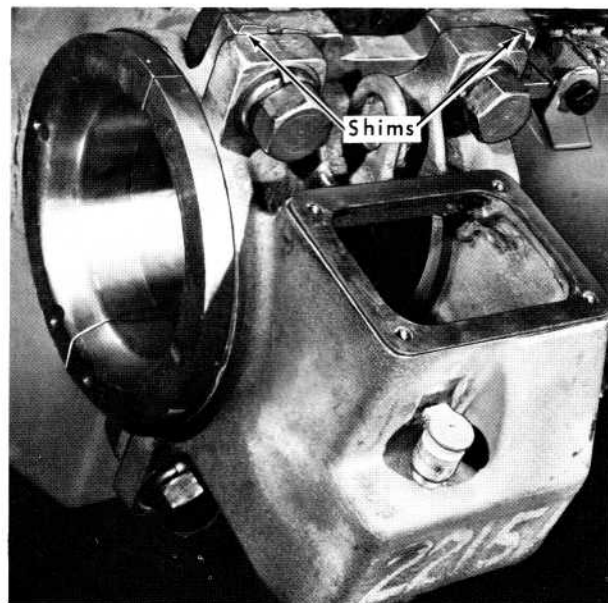

5063

Fig. 15 — Motor Support Bearing Cap

2. Check bearing serial numbers as they must be installed in matched sets.
3. Apply recommended lubricating oil on the inside diameter of bearing shells. Bearing shell flanges should contact their mating surfaces to prevent possible lateral movement.
4. The serial number on the support bearing cap and motor frame should correspond and the cap face must line up properly with the motor frame. Apply axle shield; then using the .010" shim, apply cap straight as rocking will distort splines and pinch the bearings. After proper lockwashers are installed, tighten bolts to 900 ft-lbs torque, making certain the cap is not cocked in the motor frame. Lockwire adjacent pairs of bolts.
5. The radial clearance between the axle and bearing should be at least .013". Refer to Fig. 14 for other dimensions that should be checked.
6. Apply the previously soaked felt wick lubricator assemblies. Pour oil over felt wicks, filling reservoir to proper level with recommended lubricating oil per Maintenance Instruction 1756.
7. Install gear case and axle dust guard.

CHECKING SUPPORT BEARING ALIGNMENT

Drawing 8081107 is available on request to your Electro-Motive or General Motors Overseas Operations Regional office or representative for the dimensions of a mandrel that can be constructed for checking bearing alignment on 8" axles.

For making this check, use new standard size support bearings. Install the proper support bearing caps using the .010" shims

and tighten bolts snugly. Apply the mandrel through both axle caps (wicks removed) as shown in Fig. 16 and rotate it by hand. Misalignment will be indicated if the mandrel binds and does not turn freely. The cause should be determined and corrected before placing such a motor in service.

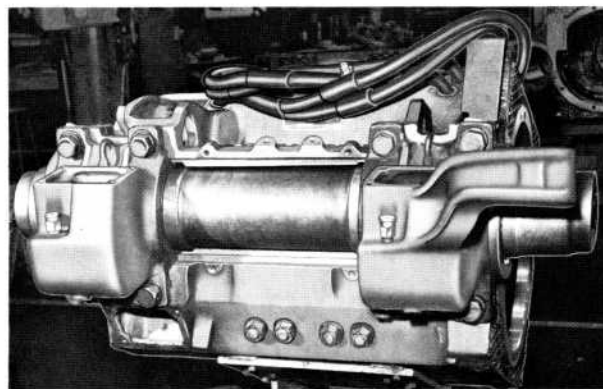

9 207

Fig. 16 — Application Of Mandrel

DUST GUARD

The dust guard, Fig. 17, is installed over the commutator end support bearing flange and the wheel hub for the purpose of keeping dirt and grit out of the bearing on this side. When installing new felts, use gasket compound (Permatex) to cement seal to retainer groove. Apply support

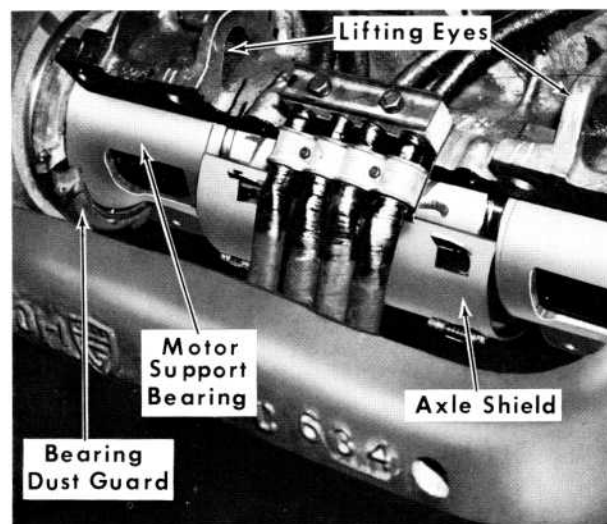

4291

Fig. 17 — Dust Guard And Axle Shield

bearing lubricating oil to felt before assembling to the axle. Make sure wheel hub is clean, then apply dust guard and observe that a good contact is made between the felt and wheel hub.

AXLE SHIELD

The axle shield shown in Fig. 17 fits over the axle between the two support bearing caps and serves to prevent dirt from entering the bearing surfaces. It is installed prior to the installation of the bearing caps.

TRACTION MOTOR REMOVAL

REMOVAL OF WHEELS AND MOTOR ASSEMBLY FROM TRUCK WITH TRUCK UNDER LOCOMOTIVE

1. Remove cleats holding motor leads to underframe.
2. Loosen and slide traction motor connector covers along the motor leads.
3. Disconnect all of the motor lead connectors, taking care to see that all leads are plainly marked so there will be no difficulty in identifying them when they are reconnected.
4. Remove the flexible air duct on commutator end of motor.
5. Remove brake rigging from wheels to be dropped.
6. Block truck with jacks on both ends.
7. Remove the pedestal tie bar from both sides of truck on wheels to be removed.
8. Remove bottom pin keeper which holds motor nose in place on the nose suspension assembly as follows:
 - a. Place a jack under motor frame and compress the motor suspension assembly.

- b. After compressing the suspension pack, place horseshoe shaped washers between the top spring holder and the heads of the spring holder bolts.

- c. Block under the traction motor before removing jack.

- d. Remove the bottom pin keeper which holds suspension assembly in place. Be sure to remove the pins which hold the spring holder and springs to truck frame.

- e. Remove the rubber suspension assembly by sliding it out from between motor and truck.

9. The motor and a pair of wheels are ready to be removed from the truck with a drop table.

REMOVAL OF TRACTION MOTOR FROM TRUCK WITH TRUCK REMOVED FROM LOCOMOTIVE

1. Remove cleats holding motor leads to underframe.
2. Slide the insulating tubes covering the connections along the motor leads.
3. Disconnect all of the motor lead connectors, taking care to see that all leads are plainly marked so there will be no difficulty in identifying them when they are reconnected.
4. Traction motor is now free and can be removed with truck.
5. Remove the dust guard on the commutator end.
6. Remove the bolts that secure the gear case.
7. Pull out gear case clips.
8. The lower half of the gear case will drop down and the upper half can be lifted off.

9. Remove the support bearing capbolts, the caps, the axle shield and the outside bearing shell.
10. Remove the bolts on the motor side of the flexible air duct.
11. Remove bottom pin keeper which holds motor nose in place on the nose suspension assembly as in Step 8 under "Removal Of Wheels And Motor Assembly From Truck With Truck Under Locomotive."
12. Lift the motor out of the truck with a crane, hooking the lifting chains into the bails on the nose side of the motor frame, Fig. 18. Rotate the motor around the axle sufficiently so that the lower lip of the support bearing housing will clear the axle and lift vertically out of the truck. Do not allow the inside bearing shell to fall on the floor.

NOTE: When mounting or removing a traction motor from a truck, or while handling in the shop, be sure that

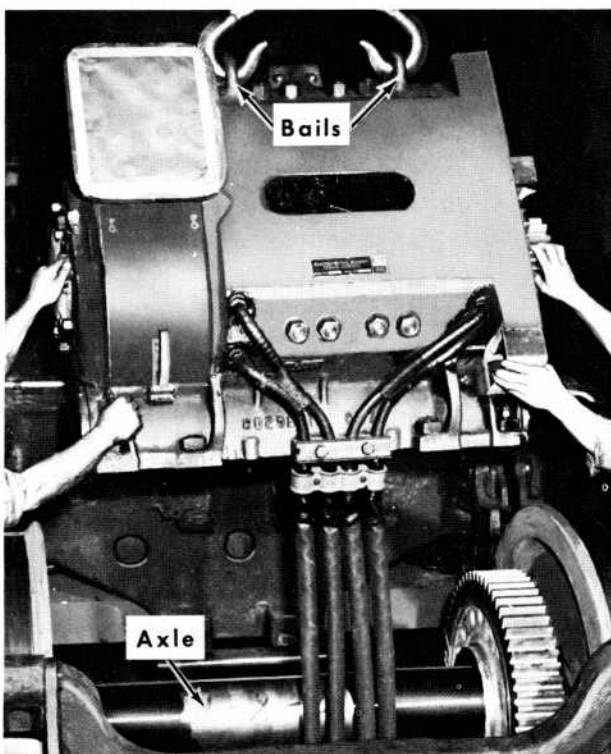

Fig 18 — Removing Traction Motor

the pinion protector 8054871 is applied. Care should always be taken to prevent the pinion from accidentally striking some object, since due to the weight of the motor it is possible to damage the pinion as well as the commutator end bearing assembly on the armature shaft.

TRACTION MOTOR NOSE SUSPENSION

Each time power is applied to the traction motors, the pinion of each motor tries to ride around the axle gear, raising the motor up or pulling it down, depending on the direction of motion. This movement of the motor is arrested by heavy lugs on the motor frame coming in contact with the top and bottom of a nose suspension assembly that is fastened to the truck frame bolster.

Effective with the D57 traction motor an improved traction motor nose suspension assembly made of resilient rubber pads and steel plates, Fig. 19, was introduced. This assembly is completely interchangeable with the previously used coil springs, and uses the same spring holders, wear plates, pins and bolts.

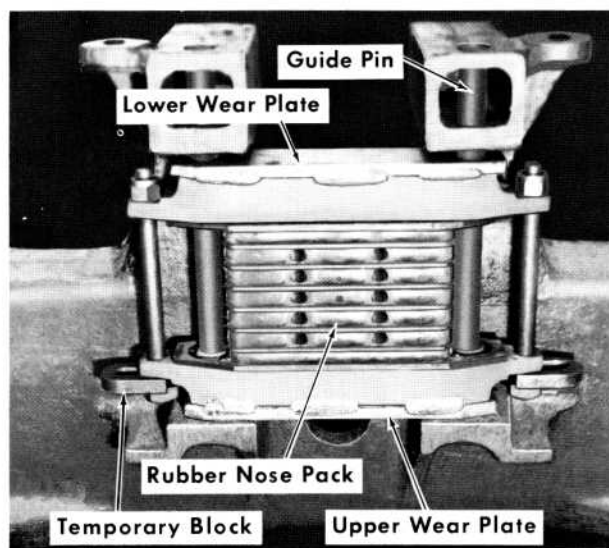

Fig. 19 — Traction Motor Nose Suspension Assembly

The wear plates on the suspension assembly are subjected to severe shocks and tremendous pressures, causing them to wear, resulting in free movement between the traction motor frame and the suspension assembly. As this free movement increases, due to wear, the severity of the shocks increases, especially if the wheels slip or during rapid changes of torque, such as applying sand during a slip.

It is recommended that wear plates be periodically reconditioned to insure not more than 1/4" free movement in the traction motor nose suspension to obtain maximum cushioning effect. Broken springs or springs which have taken a permanent set should be replaced with the rubber suspension assembly.

With the D67 traction motor a new manganese steel nose suspension wear plate, Fig. 20, was developed to obtain longer wear plate service life. This plate is interchangeable on all traction motor models.

The nose wear plate on the motor suspension nose on older models is held in place

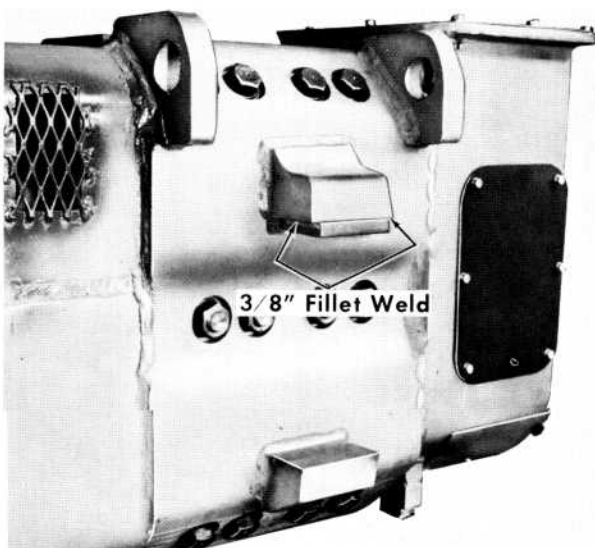

13930

Fig. 20 — Traction Motor Nose
Suspension Wear Plate

by two 3/4" diameter, 4" long rivets and wear plates on current models are welded in place. When this wear plate has worn 3/32" off its original 3/4" thickness it should be replaced. When motor suspension pack wear plates have worn 1/16" maximum, the plates should be replaced. There should be no wear on the vertical face of the truck transom supporting lugs. If there is, it indicates the lateral clearance in the journal boxes is too great and the journal boxes should be shimmed. Refer to Maintenance Instruction 1552 for journal box information.

PINIONS

The pinion mounted on the traction motor armature shaft is carburized, which provides an extremely hard outer surface yet retaining a desired soft core. These pinions are resistant to fatigue, tooth spalling and tooth wear thus providing a long service life.

The number of teeth on the pinion and mating axle gear determine the locomotive gear ratio. Various gear ratios are available to suit the specific locomotive service requirements. Pinions thus will vary from 12 teeth to 25 teeth depending on installation. Since the diameter of the 12 tooth pinion is small, it is made integral with the armature shaft; all others are removable.

PINION REMOVAL

Pinions are heated and shrunk in place on the armature shaft to provide the fit tightness necessary for them to withstand the strains imposed in locomotive operation. Thus, the removal of pinions requires the use of a special hydraulic puller and associated equipment as outlined in the Service Tools Catalog.

The procedure is as follows:

1. Remove the nut from the end of the shaft using wrench 8127529 and handle 8127528 as shown in Fig. 21.
2. Clean threads in pinion as well as those on the pulling pilot.
3. Apply spacer 8116073 between the end of the armature shaft and the ram of puller to protect the shaft from possible damage.
4. Using a suitable hoist, install threaded pilot and hydraulic puller assembly, 8239217, to pinion, Fig. 22. The threaded pilot should enter the threaded portion of the pinion gear to its complete depth. Otherwise, threads will strip and result in damage to either the gear or the pilot, or both.
5. Remove hoist before attempting to pull pinion since when pinion releases suddenly the puller and pinion will swing violently possibly damaging the equipment or motor on the return swing.

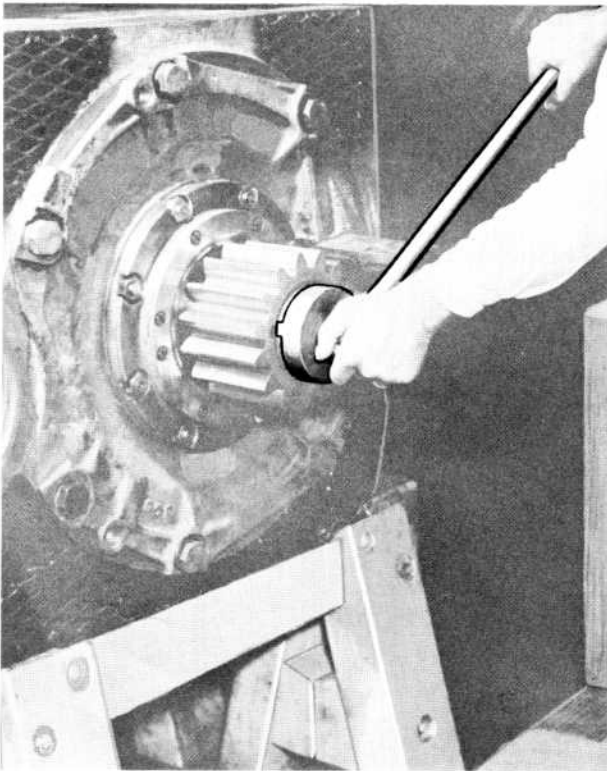

6322

Fig. 21 — Removing Nut

6. Clear area in line with pinion to avoid damage to equipment or injury to personnel, then build up pressure and pinion will come loose.

The float-off method of pinion removal can be used on shafts which are manufactured with a groove around the pinion taper which is connected by drilled passages to a 1/2"-20 tapped hole in the center of the shaft, as shown in Fig. 23. The pinion is removed by applying high pressure oil through the drilled passages to the inside of the pinion bore which results in the pinion being released from the shaft.

Procedure for float-off removal of the pinion is as follows:

1. Loosen the pinion retaining nut approximately one turn, but do not remove.
2. Clean the center of the shaft and remove the 1/2"-20 socket head set screw.

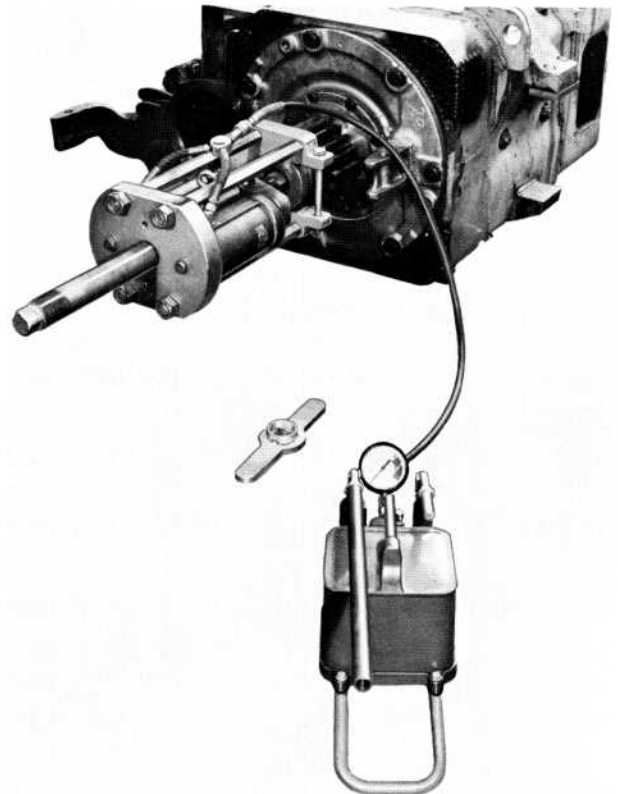

8543

Fig. 22 — Hydraulic Pinion Puller

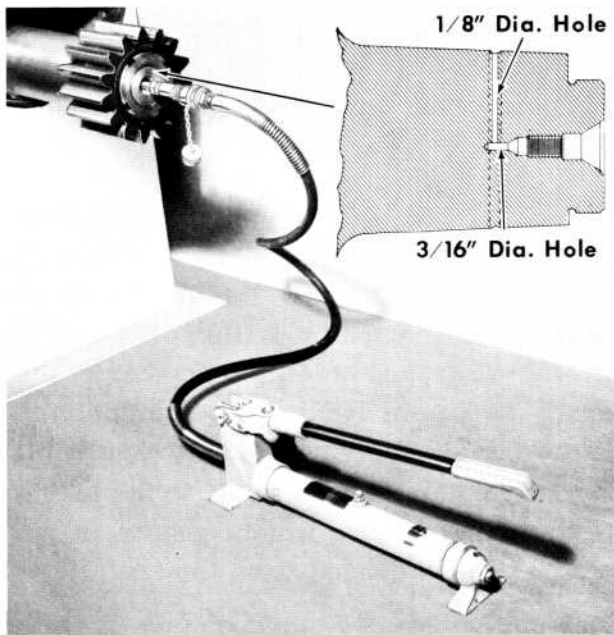

11275

Fig. 23 — Float-Off Pinion Removal

3. Make sure that threads and pressure fitting seat are clean.
4. Screw adapter nipple, 8309741, into the shaft and tighten to 25 - 30 ft-lbs. Do not overtighten as this will damage the shaft seat.
5. Connect adapter nipple to the hydraulic pump, 8309742, with the high pressure hose assembly. Close screw on pump and operate lever to build up pressure. When pressure becomes high enough, pinion will be released from the shaft and will move off against the retaining nut.
6. Remove equipment and replace set screw in end of shaft.

APPLICATION OF PINION TO SHAFT

It is essential that the pinion is carefully and properly mounted on the armature shaft in order for it to fit with the required tightness. The recommended procedure is as follows:

1. Any burrs or scoring found on armature shaft or in pinion bore should be

honed or cleaned away with Arkansas stone or grade 240 abrasive cloth.

2. Clean threads on armature shaft using a wire brush or if found damaged, run on thread chasing die 8050721. Apply pinion nut to shaft, to check for proper fit.
3. Thoroughly clean pinion bore and tapered end of armature shaft where pinion will be mounted, as the slightest bit of lint or dirt will hinder pinion application.
4. With armature shaft and pinion at room temperature, lightly mount pinion on shaft to assure proper alignment. Then using both hands, back pinion off about 1/2" and push firmly in place as far as pinion will go. Be sure pinion is mounted squarely on shaft.
5. Using micrometer depth gauge, 8160273, measure and record pinion position with respect to the shaft, Fig. 24.
6. Mark the points of measurement on the pinion, then mark the end of the shaft and pinion to retain the same angular relationship when reapplying and for final installation.
7. Remove pinion. If this proves difficult, small steel wedges may be used be-

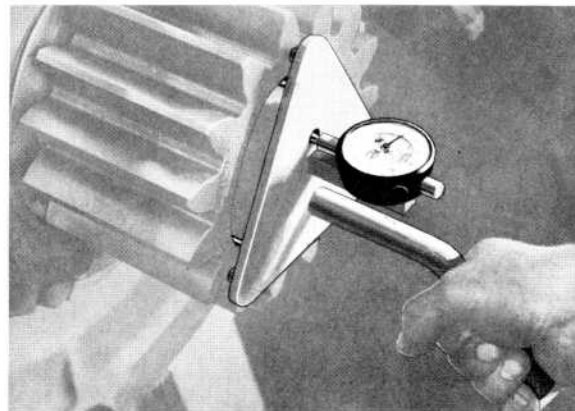

6527

Fig. 24 — Measuring Pinion Advance

tween the pinion and motor frame. To prevent damage to the motor bearing housing, a strip of copper should be placed between wedge and housing.

8. Repeat Step 4, using the mating marks previously made to insure proper relationship of pinion and shaft.
9. Apply gauge to markings and again measure and record pinion position on the shaft. Compare readings to those previously taken in Step 5. A minimum of two such cold mountings should be made to determine variations, if any, in readings. To be acceptable for final mounting, successive cold readings should not vary more than .002" to .003".

If variation exceeds these limits, again carefully clean pinion bore and shaft to eliminate all possibility of dirt or contamination. If the variation is as much as .010" then the pinion fit to shaft will have to be checked by bluing and corrections made, if necessary, by lapping. It is necessary that the pinion is in firm contact with at least 20% at the small end of the taper. The large end of the bore should not contact unless a line to line contact is obtained throughout the bore.

10. After cold mounting variations are within limits, the pinion may be heated with the induction heater, 8041446, as shown in Fig. 25 for final mounting. This is done as follows:

- a. Heat pinion to a temperature of 120° C. or 216° F. ABOVE that of the shaft. Check temperature at various points on the pinion with hand pyrometer, 8027937, taking readings ONLY when current to the induction heater is turned off. Pinion temperature should NEVER be allowed to exceed 190° C. or 374° F.

As an example of proper heating, assume the shaft temperature is found to be 75° F. The pinion should then be heated to obtain 291° F. which is the desired 216° F. rise in temperature over that of the shaft.

- b. When heated to the correct temperature, mount the hot pinion on the shaft in the same position used for the cold mountings.
- c. Measure pinion position with respect to the shaft using the micrometer depth gauge. Pinion should have advanced .050" to .060" on the shaft over the previous cold reading. The ideal advance is .055" (see Maintenance Data), however, if the position is within the limits specified, the mounting will be satisfactory.

If advance is less than .050" or more than .060" pinion will have

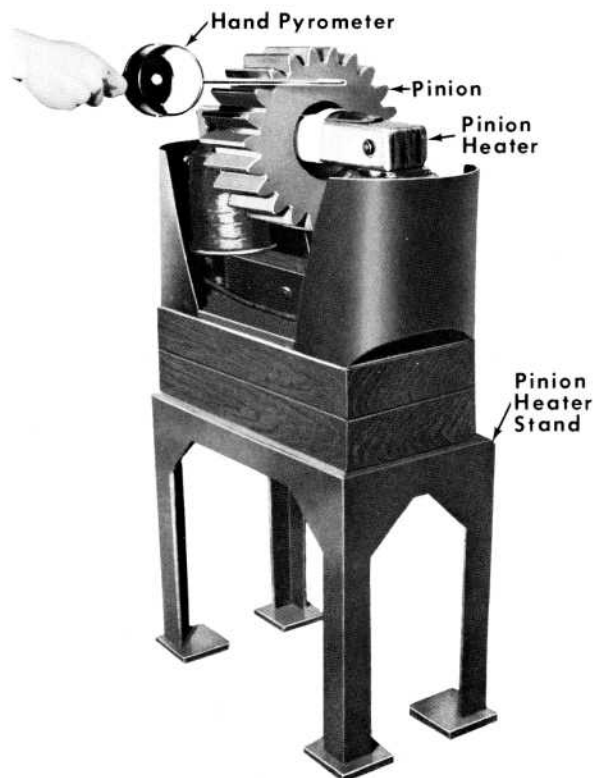

Fig. 25 — Pinion Heater

4069

to be removed and all preceding steps repeated after parts have cooled to room temperature.

- d. After final correct mounting, quickly tighten pinion nut before shaft, and pinion temperatures equalize.

TRACTION MOTOR CABLES AND CONNECTION

When installing traction motor, the cable connectors should be clean and the connections should be tight. Dirty or loose contact surfaces will cause overheating to the extent that the soldered connection between the connector and cable may be melted or the connection may be burned off completely. Connectors are applied to motor cables with a 50-50 solder using flux 8122570. Make sure rubber connector covers are in place and clamped firmly to the cables.

Check to see that the cleats holding cables to motor and clamps holding cables to underframe are tight and that sufficient swing of cables is available. Wood cleats should be dry and clean with black air drying insulating varnish 8004439 applied

when necessary. The wood cleats are made of specially treated wood and replacing them with ordinary green wood could cause detrimental results. Later motors are equipped with metal cleats.

The cable area between cleats and the rubber grommets at the motor frame should be kept clean and well covered with black air drying insulated varnish applied as necessary. Many low megger insulation readings can be attributed to dirt and moisture in this area.

CHECKING TRACTION MOTOR ROTATION

When installing traction motors, it is important to verify that cable connections have been properly made by checking motor rotation. Failure to do so may result in serious damage to the motors and generator if connections have been improperly made. Refer to wiring diagram, Fig. 26. Some older models are recabled to the latest D77 wiring diagram when rebuilt by EMD.

The direction of motor rotation can be readily determined by observing the nose suspension when power is applied. The

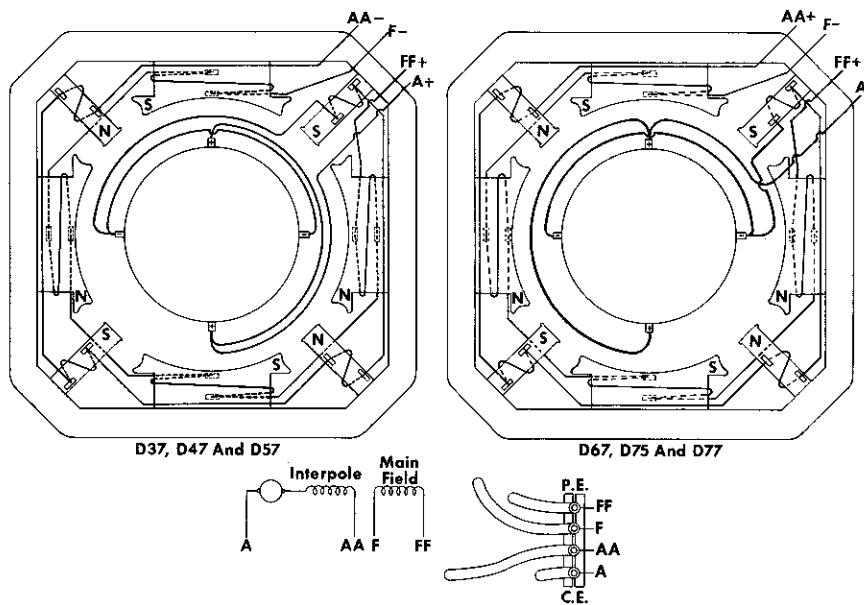

13963

Fig. 26 — Wiring Diagrams

motor frame is restrained at this point by the nose suspension assembly, yet upward or downward movement, depending on motor rotation, may be observed.

On "E" type locomotives, each truck may be checked individually by isolating the

power plant not being tested. Switchers can similarly be checked by using the truck cutout switch.

When rotation of all motors has been determined to be correct, the locomotive may be returned to service.

MAINTENANCE DATA

Brushes

Number per brush holder	3
Brush Type	Brush Grade
D37, 47 and 57 two wafer flat-top 2-1/8" x 2" x 5/8"	DE-5 (8215949) AC-35 (8256183) DE-7 (8322301) AC-100 (8350348)
D37, 47 and 57 two wafer common rubber top 2-1/8" x 2" x 5/8"	DE-7 (8404451) AC-100 (8394191)
D37, 47 and 57 three wafer floating center wafer 2-1/8" x 2" x 5/8"	DE-7 (8403347) AC-100 (8393692)
D37, 47 and 57 with 8331061 brush holder two wafer common rubber top 2-3/8" x 2" x 5/8"	DE-7 (8404453) AC-100 (8394852)
D67, 75 and 77 three wafer floating center wafer 2-3/8" x 2" x 5/8"	DE-7 (8403506) AC-100 (8391337)
Wear limit	Replace when spring pressure arm is 1/8" above brush box
Brush spring pressure	
Clock spring type	Min. 7 lbs. Max. 8-10 lbs.
Constant pressure type	3 lbs. 14 oz. ⁺ 5 oz.

Brush Holders

Number of brush holders	4
Clearance - bottom of brush holder to commutator	Min. 1/8" Max. 3/16"

Commutator

Mica groove width	.050" Max.
Mica groove depth	Min. 3/64" Max. 5/64"

Pinion Application

Heating temperature (approximate)	120° C. or 216° F. above shaft temperature
--------------------------------------	---

Advance

14 to 18 teeth	.055" ⁺ - .005"
19 to 21 teeth	.050" ⁺ - .005"
22 and 23 teeth	.045" ⁺ - .005"

Air Gap (nominal)

Main pole	.234"
Interpole	.285"

Resistance (at 75° C.)

D37, D47, D57, D67,	
D75 Armature	.01446 ohms ⁺ - 2%
D77 Armature	.01232 ohms ⁺ - 2%
D37 series field circuit	.00975 ohms ⁺ - 2%
D47, D57, D67, D75, D77,	
series field circuit	.00876 ohms ⁺ - 2%
D37 interpole circuit	.00745 ohms ⁺ - 2%
D47, D57, D67, D75,	
D77 interpole circuit	.00652 ohms ⁺ - 2%

Armature Bearings

Lubricant (sealed grease)	Shell Cyprina RA (see M.I. 6850 for application)
Lubricant (oil)	As specified in M.I. 1756 - Apply according to applicable Scheduled Maintenance Program.

Support Bearings

Lubricant	As specified in M.I. 1756
Lubricant Level	
Wide window bearing	Min. 2-1/2" Max. 5"
Narrow window	Min. 2-1/2" Max. 6-1/2"
Narrow window with overflow	Min. 2-1/2" Max. 5-1/2"
Wear limits	See Fig. 14

Gear Case

Support arm wear limit	3-31/32"
Lubricant	See M.I. 1756
Initial charge of lubricant	10 lbs.

Weights (approximate)

Complete motor	6150 lbs.
Armature	1810 lbs.
Gear Case	150 lbs.

SPECIAL TOOLS

Pyrometer - Hand type	8027937
Heater - Induction type pinion.	8041446
Die - Armature shaft rethreading	8050721
Protector - Pinion	8054871
Spacer	8116073
Handle - Sliding "T"	8127528
Wrench - Pinion Nut	8127529
Lifter - Brush springs	8140869
Depth Gauge - Pinion advance.	8160273
Dispenser - Lube Oil	8191382
Bar - Alignment.	8210141
File - Commutator Slot.	8238905
Puller - Hydraulic Pinion	8239217
Remover - Installer - Filler Cap	8250241
Aligning Tool.	8305181
Pinion Remover.	8309742
Adapter - Commutator Grinder (Frame Mounted).	8354226
Adapter - Commutator Grinder (Brush Holder Mounted)	8354239
Grinder - Commutator	8355891