



MAINTENANCE INSTRUCTION

M. I. 3707 - Revision C

***Publication revised and supersedes previous issues of this number.**

AC AUXILIARY / EXCITER ALTERNATORS (BRUSHLESS TYPE)

**MODELS A-8146, A-8147, A-8147-M1,
2A-8147, 3A-8147, 5A-8147, A-8589**

RUNNING MAINTENANCE AND OVERHAUL INSTRUCTIONS

Service Department
ELECTRO-MOTIVE DIVISION
GENERAL MOTORS CORPORATION
July, 2001

SAFETY PRECAUTIONS

Please refer to the EMD [Safety Precautions](#) in appendix to the Locomotive Service Manual whenever routine service or maintenance work is to be performed on any AC traction equipped locomotive.

The maintenance procedure as outlined in this instruction is specific to AC Auxiliary/Exciter Alternators and is offered for planning purposes only. As written, this document reflects current EMD product design and service experience for this design. The content of this M.I. reflects maintenance requirements based on time from delivery or miles in service. This recommendation is consistent with present fleet performance and remains within the EMD experience envelope.

This Maintenance Instruction is intended to serve as a guide when establishing maintenance schedules to meet the particular requirements of individual operations and planned economic life of the AC Auxiliary/Exciter alternator. It provides average recommendations, which should ensure satisfactory locomotive operation, and economical maintenance costs where average load factors and climatic conditions are encountered.

The scheduled inspection and maintenance items defined herein are specific to the AC Auxiliary/Exciter Alternators. Component renewal provisions are consistent with traditional overhaul procedures.

For planning purposes, EMD has established the following overhaul interval recommendations for the AC Auxiliary/Exciter Alternator. These overhaul interval recommendations are based on whichever event occurs first: time, miles, or megawatt hours.

AC Auxiliary/Exciter Alternators:

- High Speed Service: 8 years / 1,000,000 miles.
- Heavy Haul Service: 8 years / 750,000 miles.

NOTE

Mileage values referenced above are defined by Microprocessor Archive Data as accumulated by the locomotive control computer system.

As always, when specific operating conditions severely impact locomotive performance and or reliability, maintenance schedules must be adjusted accordingly.

© Copyright 2001

Electro-Motive Division, General Motors Corporation.

Prepared by International Technical Services – London, Ontario, Canada

All rights reserved. Neither this document, nor any part thereof, may be reprinted without the expressed written consent of the Electro-Motive Division. Contact EMD Service Publications Office.

Table of Contents

1.0 INTRODUCTION	5
2.0 DESCRIPTION	7
2.1 ROTOR	7
2.2 STATOR	7
2.3 EXCITER.....	8
2.4 END FRAMES.....	8
2.5 COMPARISON OF MODELS	8
3.0 RUNNING MAINTENANCE	9
3.1 ROUTINE CLEANING	9
3.2 LUBRICATION.....	9
4.0 OVERHAUL PROCEEDURES	9
4.1 DISASSEMBLY	9
4.2 INSPECTION AND TEST	11
4.2.1 RECTIFIER ASSEMBLY.....	11
4.2.1.1 CORRECT ORIENTATION TEST.....	13
4.2.1.2 SHORTED RECTIFIER TEST.....	14
4.2.1.3 OPEN CIRCUIT TEST.....	14
4.2.1.4 ACCEPTABLE RECTIFIER.....	14
4.2.2 EXCITER ARMATURE AND ROTATING ALTERNATOR FIELD ASSEMBLY	14
4.2.2.1 EXCITER ARMATURE ASSEMBLY	15
4.2.2.2 ROTATING ALTERNATOR FIELD ASSEMBLY	16
4.2.3 FAN ASSEMBLY (If unit is so equipped).....	18
4.2.4 BEARING HOUSING.....	18
4.2.5 ALTERNATOR STATOR ASSEMBLY AND EXCITER FIELD ASSEMBLY	19
4.2.5.1 ALTERNATOR STATOR ASSEMBLY	20
4.2.5.2 ALTERNATOR STATOR ASSEMBLY LEADS	21
4.2.5.3 VARNISH DIP AND BAKE.....	21
4.2.5.4 ALTERNATOR STATOR REPLACEMENT.....	21
4.2.6 EXCITER FIELD ASSEMBLY	22
4.2.6.1 EXCITER FIELD LEADS.....	23
4.3 REASSEMBLY	23
4.3.1 ROTATING FIELD AND ARMATURE ASSEMBLY.....	23
4.3.2 ROTOR TO STATOR FRAME REASSEMBLY	26
4.3.3 END FRAMES AND BEARING HOUSINGS.....	27
5.0 FINAL TESTING	28
5.1 GENERATED RESIDUAL VOLTAGE	28
5.2 NO LOAD SATURATION	31
5.3 SYNCHRONOUS IMPEDANCE.....	31
5.4 SELF-EXCITE AND REGULATION TEST	32
6.0 SERVICE DATA	33
6.1 REFERENCES.....	33
6.2 SPECIFICATIONS	33
6.3 MATERIAL LIST.....	33

1.0 INTRODUCTION

All of these brush-less AC auxiliary/exciter alternators (fig. 1) are series wound, alternating current, three-phase alternators. They are used to excite a larger generator in heavy equipment.

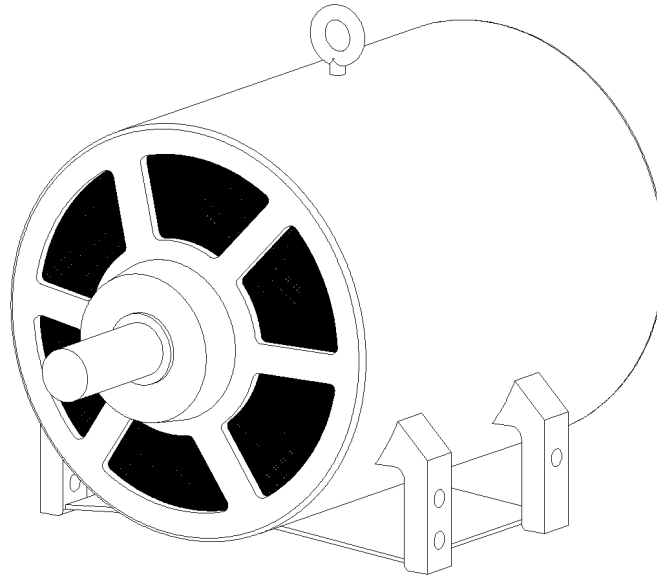

EE47021

Fig. 1 - Model A-8589 Auxiliary Generator

Model A-8146 is used on off-highway vehicles and Models A-8147, A-8147-M1, 2A-8147, 3A-8147, 5A-8147 and A-8589 are used on locomotives.

In most locomotive applications, the auxiliary alternator (generator) provides a 55 VAC output which is in turn rectified to DC for battery charging, control circuitry voltage supply, and excitation of the CA series companion alternator.

For DE and DM series locomotive applications, the machine is used as an exciter alternator for the TA series Traction Alternator. In this case the output is used with an SCR assembly to provide TA field excitation.

Each generator consists of a rotating alternator field assembly (rotor), alternator stator assembly (stator), an internal exciter, ball bearings, end frames, and all models with the exception of Model A-8589 are equipped with a cooling fan. Refer to Figure 2 on page 6 or Figure 3 on page 7, depending upon the model.

The generators are directly driven at various speeds by an auxiliary power take-off and normally supply 55 VAC, three phase power, with an output capacity of 18 or 24 kilowatts.

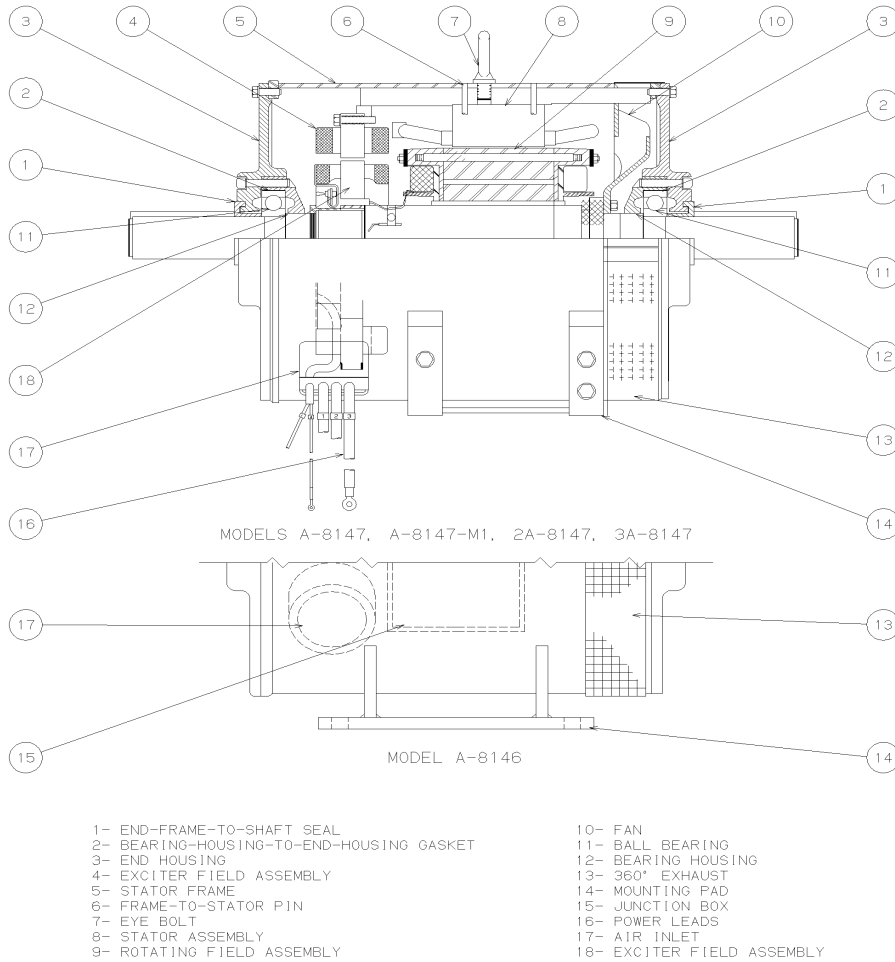

EE30933

Fig. 2 - Models A-8146, A-8147, A-8147-M1, 2A-8147, 3A-8147

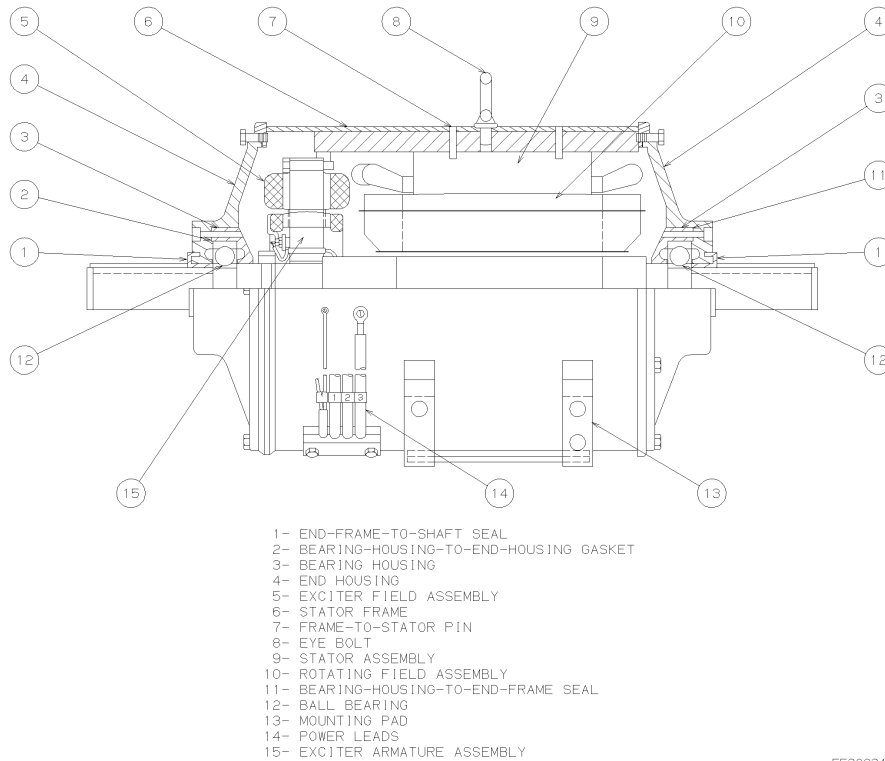

Fig. 3 – Models 5A-8147 and A-8589

2.0 DESCRIPTION

2.1 ROTOR

The rotor consists of field coils wound on laminated poles, which are heat shrunk onto a shaft. The coils are connected in series and the leads are brought out to the rectifier mounting assembly. The coils are energized by the exciter output applied at the rectifier mounting assembly. The rotor coils are insulated with Class F insulation.

2.2 STATOR

The stator consists of coil groups embedded in semi-enclosed slots of a laminated core. This core and coil assembly is pressed and pinned into a main frame of fabricated steel construction. The stator coils are insulated with Class H insulation.

2.3 EXCITER

The internal exciter consists of a field coil assembly, an armature, and a rectifier assembly.

The exciter field coil assembly consists of a lamination assembly with twelve field coils connected in series. The exciter field assembly is insulated with Class F insulation. This assembly is bolted to a main frame

The exciter armature has a three-phase, three-wire wye, and a twelve-pole winding. This assembly is made up of conventional coil groups and slotted steel laminations, which are keyed to the armature shaft. The exciter armature is insulated with Class H insulation.

The rectifier assembly rectifies the AC output of the exciter armature and supplies DC to the rotating field coils. This assembly has a printed circuit on each side of the mounting plate.

2.4 END FRAMES

The end frames support the ball bearing housings and contain grease reservoirs.

2.5 COMPARISON OF MODELS

All models of these auxiliary generators have similar electrical characteristics, but are modified to provide different mounting arrangements and other mechanical improvements. The differences are as follows:

Model A-8147 is the original design auxiliary generator. At the time of rebuild, the generator should be changed to a Model A-8147-M1 configuration which has an improved bearing housing with larger grease capacity for longer bearing life.

Model 2A-8147 is interchangeable with Model A-8147-M1, and has redesigned bearing caps, shaft seals, exciter end-frame (to ensure clamped bearing is always on the fan end), and improved ventilation.

Model 3A-8147 is similar to Model 2A-8147 with an improved stator and coil assembly and exciter assembly.

Model 5A-8147 is similar to Model 3A-8147 electrically, but uses a re-designed frame and end frame assembly similar to the model A-8589.

Model A-8146 is designed to be mounted vertically and has an air inlet tub to allow a flexible hose from an external air supply to be attached. It is also the only model with a junction box on the side of the stator for power leads.

Model A-8589 has a few common parts with the earlier models, but is a larger, completely re-designed machine.

3.0 RUNNING MAINTENANCE

The generators are designed and manufactured to provide long life and satisfying performance with a minimum of maintenance. Like any machine, however, certain maintenance is required, as determined by the operation and service to which the generator is subjected. Inspections and maintenance should be performed on the systematic basis outlined in the Scheduled Maintenance Program.

3.1 ROUTINE CLEANING

The interior and exterior of the generator should be kept clean and free of dust, dirt, oil, and water which are likely to have a detrimental effect on the insulation and performance.

As frequently as conditions warrant, the generator should be blown out with high volume, low pressure, clean, dry compressed air (25-psi max.). Avoid excessive air pressure, which could damage the insulation.

Clean, bound-edge, lint-less, wiping cloths should be used as necessary to remove oil, grease, and accumulations of dirt.

3.2 LUBRICATION

Grease lubricated ball bearings are assembled within the bearing housings containing grease reservoirs. During an overhaul or tear down, grease should be renewed. No additional lubrication is required.

4.0 OVERHAUL PROCEDURES

4.1 DISASSEMBLY

The generator can be disassembled without special tools. However, repairs should not be attempted by anyone who is not an experienced electrical mechanic. The following procedures should be thoroughly studied before any repair operation is started. During disassembly, refer to Figure 2 on page 5 or Figure 3 on page 6.

1. Mount generator on a sturdy stand at a suitable height from the floor.

2. Remove fan cover band, if unit is so equipped.
3. Remove shaft keys from both ends of the shaft.
4. Remove bolts securing end frames (both ends) to stator.
5. Remove end frames by prying straight out.
6. Remove the rotor from the stator as follows:
 - a) Place an extension pipe over the exciter end of the shaft.

CAUTION

Protect the portion of the shaft, which will be enclosed by the extension pipe to prevent damage to the shaft.

- b) With the aid of a suitable hoist, raise the extension pipe until the air gap is equal around the circumference of the rotor. With the aid of a second hoist, raise the other end of the shaft until the shaft is level.
 - c) Carefully remove the rotor assembly from the stator from the end opposite the exciter, until it clears the stator assembly.
7. Place the rotor on a suitable stand or saddle.
8. Remove bearing housings (both ends).
9. Remove ball bearings from both ends as follows:
 - a) Heat bearing collars to soften the sealant.
 - b) Using a standard bearing or gear puller, remove bearings and collars from the shaft.

NOTE

New bearings are to be used on both ends during re-assembly.

10. Remove exciter locknut and lockwasher, Figure 4, as follows:
 - a) Disengage the tab of the lockwasher that is bent to engage a notch in the locknut.
 - b) Tap loose with a bar and hammer.
 - c) Discard lockwasher.

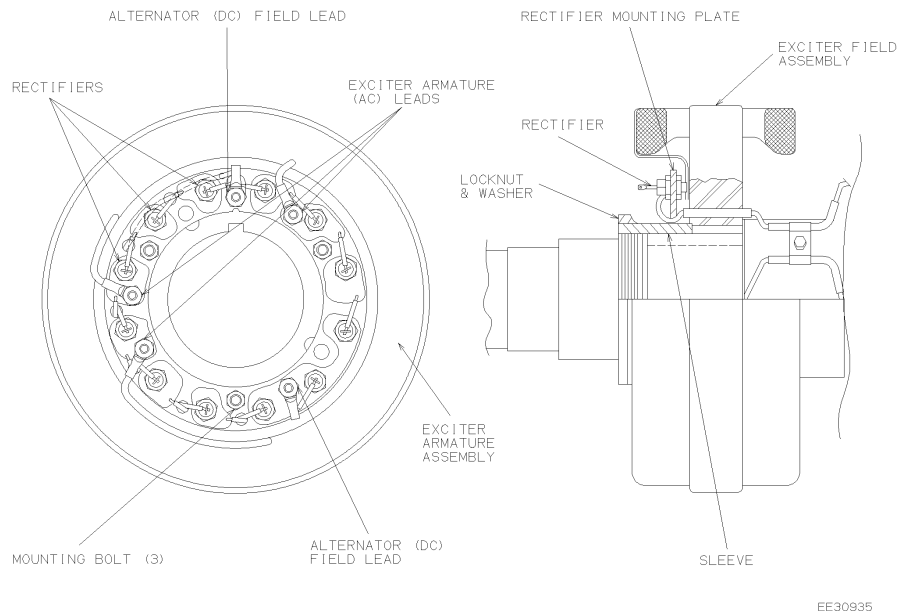

Fig. 4 - Rectifier Assembly

11. Remove the wrap of tape and remove sleeve. Retain the sleeve for reuse.
12. Carefully unsolder the two alternator (DC) field leads, which pass through the core of the exciter armature assembly.
13. Carefully unsolder the three exciter armature (AC) leads.
14. Remove the nuts from the three mounting bolts.
15. Remove the rectifier assembly from the shaft.

4.2 INSPECTION AND TEST

When the auxiliary/exciter alternator is dismantled for repair, all parts should be carefully cleaned and carefully inspected before assembly.

4.2.1 RECTIFIER ASSEMBLY

1. Clean the rectifier assembly with a light “bead blast” to remove paint and dirt to expose circuit board surface to facilitate electrical contact.
2. Determine configuration of rectifier assembly. Place rectifier assembly “face up” and refer to Figure 5, page 13.

If rectifier assembly is 4965900, originally supplied with Models A-8146, A-8147, A-8147-M1, or 2A-8147, identified by the three rectifier common bus and having rectifiers of both polarities (6 negative and 6 positive), do not replace board if damaged or replace rectifiers if they are defective. Scrap the assembly and replace with rectifier assembly 2802925.

NOTE

Rectifier assembly 2802925 and rectifier assembly 2803017 are not interchangeable.

3. Using an ohmmeter set to RX1, check the rectifiers for correct orientation, short circuits, and open circuits.

NOTE

If a digital meter with a diode function, such as a John Fluke Model 8030 Multi-meter is used, a “high” flashing number, such as 1999, indicates high resistance. A steady 000, indicates a short. A steady low number, such as 300 – 600, indicates low resistance.

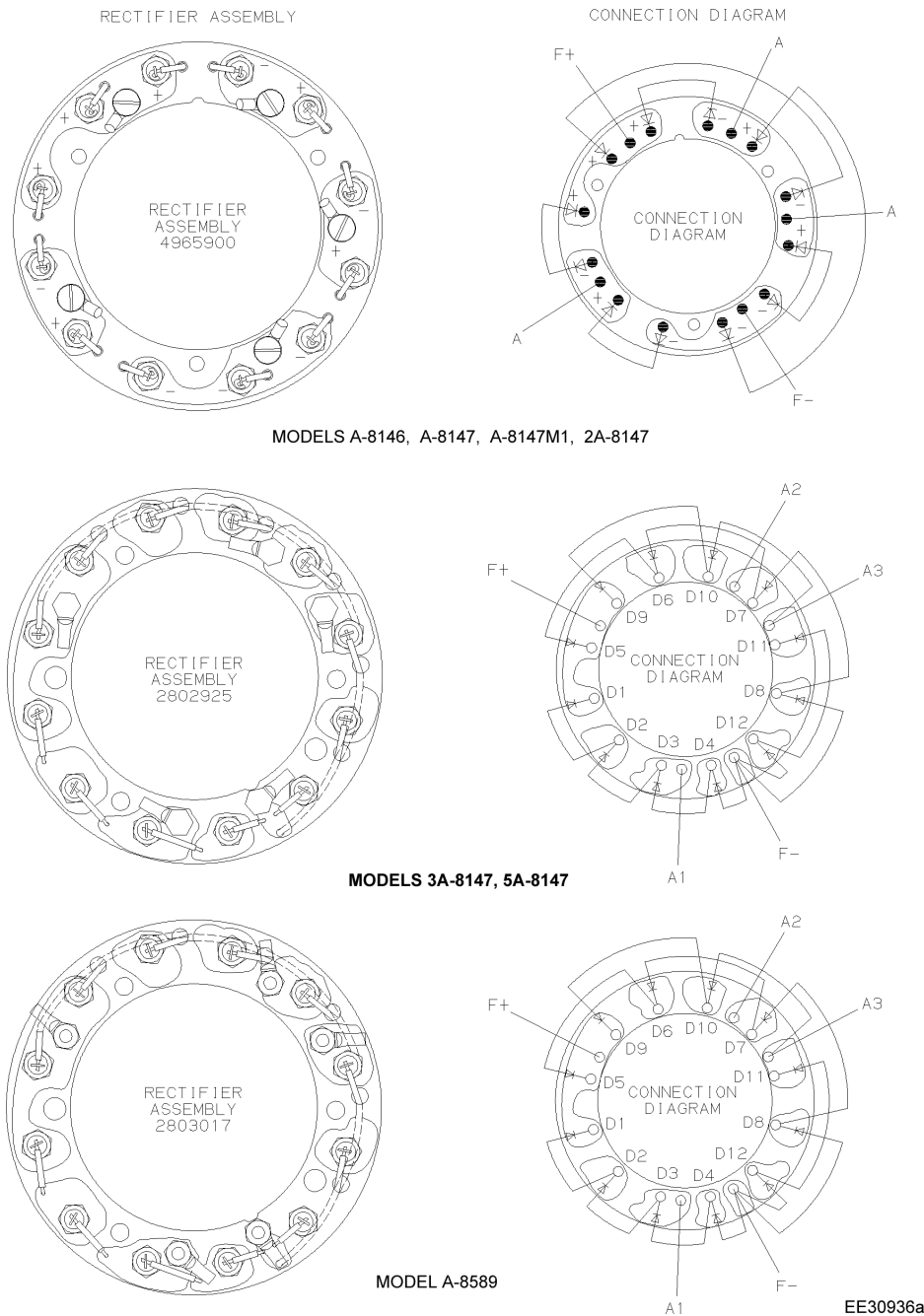

Fig. 5 - Rectifier Assembly Configurations

4.2.1.1 CORRECT ORIENTATION TEST

Connect ohmmeter positive lead to lead of rectifier. Connect ohmmeter negative lead to base of rectifier. Low resistance, approximately 17 – 30 ohms, indicates correct orientation.

4.2.1.2 SHORTED RECTIFIER TEST

Connect ohmmeter positive lead to base of rectifier. Connect ohmmeter negative lead to lead of rectifier. Short indicated by near zero resistance.

4.2.1.3 OPEN CIRCUIT TEST

High resistance both ways indicates an open circuit.

4.2.1.4 ACCEPTABLE RECTIFIER

Connect ohmmeter positive lead to base of rectifier. Connect ohmmeter negative lead to lead of rectifier. High resistance indicates an acceptable rectifier.

1. Replace any rectifier not meeting requirements with rectifier 3179357.
2. Torque rectifiers to 1.2 – 2.1 N•m (11 – 19 in-lbs.). Align any terminal hardware removed as shown in Figure 5 on 11. Torque hardware to 1.7 – 2.3 N•m (15 – 20 lbs.).

4.2.2 EXCITER ARMATURE AND ROTATING ALTERNATOR FIELD ASSEMBLY

Clean the exciter armature and rotating alternator field assembly, Figure 6, page 14, by blowing out dust, dirt, and other contaminants using high volume, low pressure, clean, dry, compressed air (25-psi max). Avoid excessive air pressure that could damage the insulation.

If there is remaining dirt, wipe assembly with a clean cloth dampened with a suitable solvent such as Stoddards Solvent.

WARNING

Provide adequate ventilation when using solvents. The usual precautions should be observed when handling inflammable fluids such as Stoddards Solvent which has a flash point of 46°C (257° F).

In the event that the assembly is extremely dirty or oily, the surface may be cleaned with a solution such as Calgon NP-92 and steam clean. If cleaned in this manner, the assembly must be thoroughly rinsed with a copious water flush. Dry assembly in an oven at 125°C (257°F) for four hours.

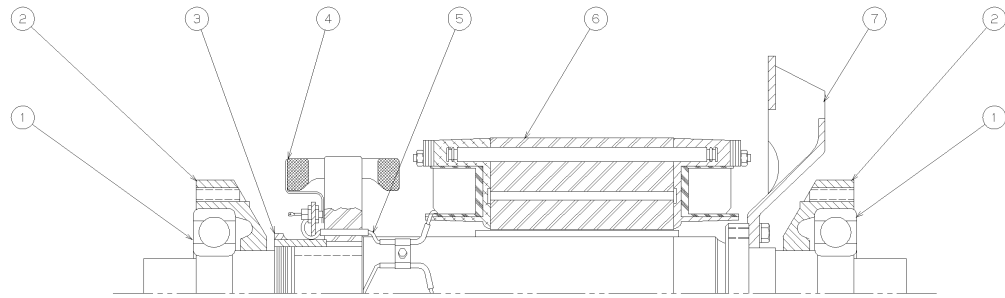

MODELS A-8146, A-8147, A-8147-M1
2A-8147, 3A-8147

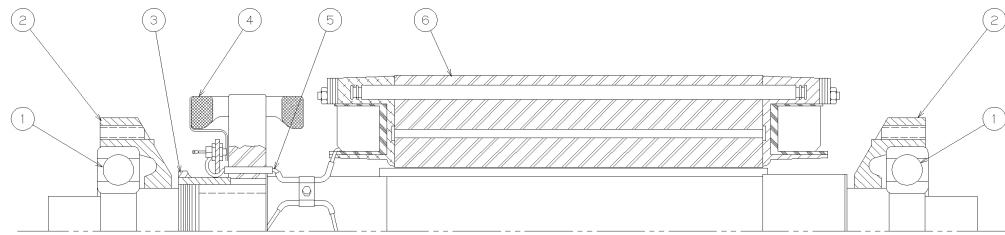

MODELS 5A-8147, A-8589

- 1- BALL BEARING
- 2- BEARING HOUSING
- 3- LOCKNUT AND LOCKWASHER
- 4- EXCITER ARMATURE ASSEMBLY
- 5- DC FIELD LEADS
- 6- ROTATING ALTERNATOR FIELD ASSEMBLY
- 7- ALTERNATOR FAN

EE30937a

Fig. 6 - Armature and Field Assembly

4.2.2.1 EXCITER ARMATURE ASSEMBLY

Electrically test the exciter armature assembly as follows:

NOTE

The formula used to convert resistance under ambient (room temperature) conditions to a nominal resistance at 75°C (167°F) may be found in the Service Data.

TEST	A-8146 A-8147 A-8147-M1 2A-8147	3A-8147 5A-8147	A8589
Ohmmeter Resistance at 75°C (167°F)	0.430-0.476 ohms	1.693-1.884 ohms	0.839-0.927 ohms
500 V Megger	10 Megohms minimum	10 Megohms minimum	10 Megohms minimum
1500V Hi-Pot	1 second	1 second	1 second

Table 1 – Exciter Armature Resistance Values

Conduct a Surge Comparison Test, using an insulation analyzer such as a P.J. Electronics Coil Insulation Analyzer, Model 6920. Test voltage to be 1500V.

Temporarily “tag and identify” the three leads, randomly as #1, #2, and #3. Do not connect the ground lead. Connect the P.J. Electronics Analyzer as follows:

Analyzer Leads	Winding Leads	Compares
Red	1	1-2
Green	2	
Black	3	
Red	2	2-3
Green	3	
Black	1	
Red	3	1-3
Green	1	
Black	2	

Table 2 – P.J. Electronic Analyzer Connections

The waves shown on the screen must be the same in either direction of travel (a single wave should be seen). However, if this symmetry is disturbed by a ground, shorted turn, incorrect connection, or the wrong number of turns, the waves for the two directions of travel will differ, and two waves of different shapes will appear on the screen.

If the exciter armature fails to meet the test requirements, replace the exciter armature with a new assembly.

4.2.2.2 ROTATING ALTERNATOR FIELD ASSEMBLY

Electrically test the rotating alternator field assembly as follows:

NOTE

The formula used to convert resistance under ambient (room temperature) conditions to a nominal resistance at 75°C (167°F) may be found in the Service Data.

TEST	A-8146 A-8147 A-8147-M1 2A-8147	3A-8147 5A-8147	A8589
Ohmmeter Resistance at 75°C (167°F)	2.80-2.95 ohms	2.80-2.95 ohms	4.25-4.49 ohms
500 V Megger	10 Megohms minimum	10 Megohms minimum	10 Megohms minimum
1500V Hi-Pot	1 second	1 second	1 second
Watt Meter Impedance Test at 110V, 60Hz	31.8-36.9 watts	31.8-36.9 watts	14.8-17.2 watts

Table 3 - Rotating Alternator Field Assembly Resistance Values

Conduct a Surge Comparison Test, using an insulation analyzer such as a P.J. Electronics Coil Insulation Analyzer, Model 6920. Test voltage to be 1500V.

Temporarily “tag and identify” the three leads, randomly as #1, #2, and #3. Do not connect the ground lead. Connect the P.J. Electronics Analyzer as follows:

Analyzer Leads	Winding Leads	Compares
Red Green Black	1 2 3	1-2
Red Green Black	2 3 1	2-3
Red Green Black	3 1 2	1-3

Table 4 - P.J. Electronic Analyzer Connections

The waves shown on the screen must be the same in either direction of travel (a single wave should be seen). However, if this symmetry is disturbed by a ground, shorted turn, incorrect connection, or the wrong number of turns, the waves for the two direction of travel will differ, and two waves of different shapes will appear on the screen.

NOTE

It is not possible to remove the shaft assembly from the rotating field assembly. If the rotating field assembly is defective, it will be necessary to replace the rotating field assembly and the shaft assembly with new assemblies.

If the rotating alternator field assembly fails to meet the test requirements, the rotating alternator field assembly and the shaft assembly will have to be replaced with new assemblies.

If after inspection it is determined that the shaft assembly must be replaced, the shaft assembly and the rotating alternator field assembly will have to be replaced with new assemblies.

4.2.3 FAN ASSEMBLY (If unit is so equipped)

Clean fan assembly. Inspect for damage, cracks, and fissures. Replace fan assembly with a new assembly if required.

4.2.4 BEARING HOUSING

Clean bearing housings. Inspect housings and bores. Bearing bore diameter should be 129.995 – 130.015 mm (5.1179” – 5.1187). Refer to Figure 7 on page 18.

Replace bearing housing with a new bearing housing if bore diameter is not within tolerance or if bearing outer race movement is apparent.

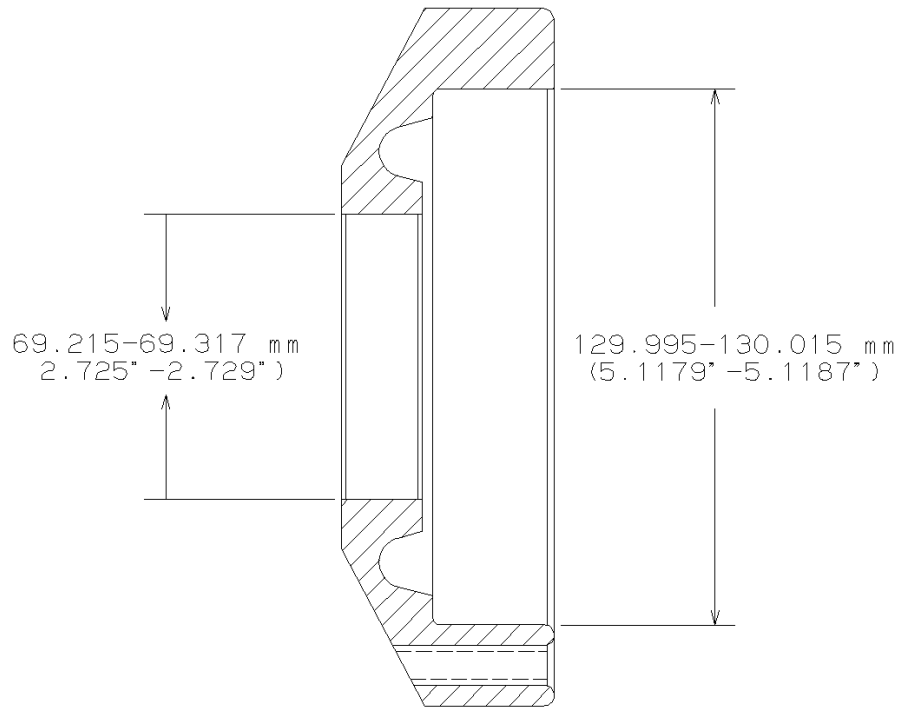

EE30938

Fig 7 - Bearing Housing

4.2.5 ALTERNATOR STATOR ASSEMBLY AND EXCITER FIELD ASSEMBLY

Clean the stator and exciter field assembly by blowing out dirt, dust, and other contaminants using high volume, low pressure, clean, dry, compressed air (25-psi max.). Avoid excessive air pressure that could damage insulation.

If there is remaining dirt, wipe assembly with a clean cloth dampened with a suitable solvent such as Stoddards Solvent.

WARNING

Provide adequate ventilation when using solvents. The usual precautions should be observed when handling inflammable fluids such as Stoddards Solvent which has a flash point of 46°C (257°F).

In the event that the assembly is extremely dirty or oily, the surface may be cleaned with a solution such as Calgon NP-92 and steam clean. If cleaned in this manner, the assembly must be thoroughly rinsed with a copious water flush. Dry the assembly in an oven for four hours at 125°C (275°F).

4.2.5.1 ALTERNATOR STATOR ASSEMBLY

Electrically test the alternator stator assembly as follows:

NOTE

The formula used to convert resistance under ambient (room temperature) conditions to a nominal resistance at 75°C (167°F) may be found in the Service Data.

TEST	A-8146 A-8147 A-8147-M1 2A-8147	3A-8147 5A-8147	A8589
Ohmmeter Resistance at 75°C (167°F)	0.0230-0.0254 ohms	0.0383-0.0423 ohms	0.0304-0.0335 ohms
500 V Megger	10 Megohms minimum	10 Megohms minimum	10 Megohms minimum
1500V Hi-Pot	1 second	1 second	1 second

Table 5 – Alternator Stator Assembly Resistance Values

Conduct a Surge Comparison Test, using an insulation analyzer such as a P.J. Electronics Coil Insulation Analyzer, Model 6920. Test voltage to be 1500V.

Temporarily “tag and identify” the three leads, randomly as #1, #2, and #3. Do not connect the ground lead. Connect the P.J. Electronics Analyzer as follows:

Analyzer Leads	Winding Leads	Compares
Red	1	1-2
Green	2	
Black	3	
Red	2	2-3
Green	3	
Black	1	
Red	3	1-3
Green	1	
Black	2	

Table 6 - P.J. Electronic Analyzer Connections

The waves shown on the screen must be the same in either direction of travel (a single wave should be seen). However, if this symmetry is disturbed by a ground, shorted turn, incorrect connection, or the wrong number of turns, the waves for the two directions of travel will differ, and two waves of different shapes will appear on the screen.

4.2.5.2 ALTERNATOR STATOR ASSEMBLY LEADS

Exciter field leads should be tagged “1-2-3,” left to right and should be re-tagged if required.

If leads are damaged, the alternator stator assembly could require replacement, depending upon the extent of the damage. Reasonable repair should be considered.

4.2.5.3 VARNISH DIP AND BAKE

Frames may be varnish-dipped and baked if deemed necessary. However, if done, use care to maintain varnish-free threaded bolt holes, end frame interfaces, ventilation holes, mounting feet, etc.

4.2.5.4 ALTERNATOR STATOR REPLACEMENT

If the alternator stator assembly fails to meet the test requirements, the alternator stator assembly will have to be replaced with a new assembly.

Remove the stator assembly from the frame as follows:

1. Drill down through the four frame-to-stator pins. Refer to Figure 8 on page 20.
2. Press the stator assembly out through the end opposite the exciter field assembly.
3. Press new assembly in from the same end and ensure assembly seats flat against the stop in the frame.
4. Drill four new 6.32 – 6.50 mm (0.246” – 0.256”). Refer to Figure 8 on page 20.
5. Install new frame-to-stator pins.

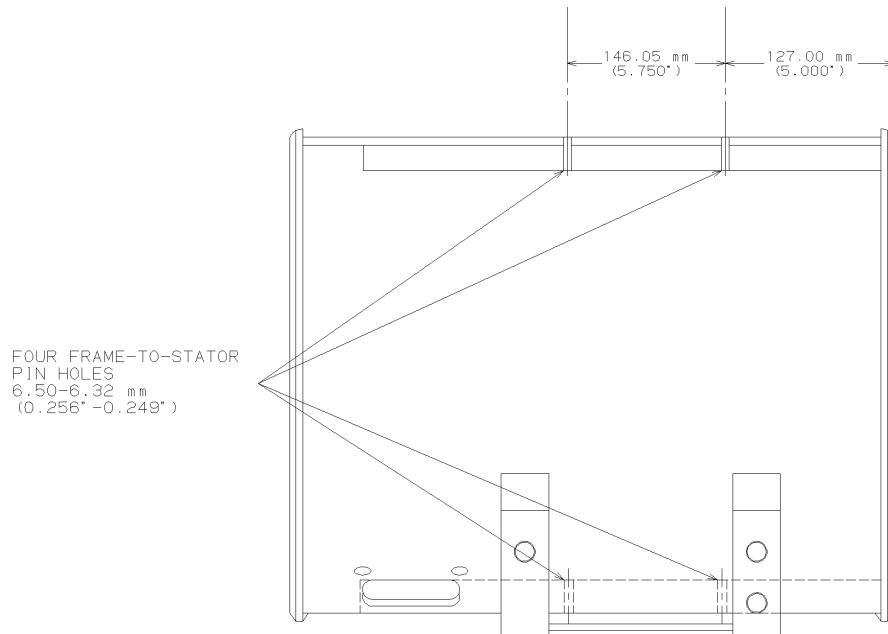

EE30939

Fig. 8 - Frame-to-Stator-Pin Holes Location

4.2.6 EXCITER FIELD ASSEMBLY

Electrically test the exciter field assembly as follows:

NOTE

The formula used to convert resistance under ambient (room temperature) conditions to a nominal resistance at 75°C (167°F) may be found in the Service Data.

TEST	A-8146 A-8147 A-8147-M1 2A-8147	3A-8147 5A-8147	A8589
Ohmmeter Resistance at 75°C (167°F)	3.17-3.51 ohms	3.17-3.51 ohms	3.43-3.79 ohms
500 V Megger	10 Megohms minimum	10 Megohms minimum	10 Megohms minimum
1500V Hi-Pot	1 second	1 second	1 second
Watt Meter Impedance Test at 110V, 60Hz	38.9-41.5 watts	38.9-41.5 watts	32-34 watts

Table 7 - Rotating Alternator Field Assembly Resistance Values

4.2.6.1 EXCITER FIELD LEADS

Exciter Field leads should be tagged as “F+” and “F-“. If they are missing, replace with appropriate tags. The “F+” lead, when viewing exciter field assembly from exciter end of frame, is the lead on the left side.

If the leads are damaged or cutoff less than 292 mm (11 -1/2”) from the clamp, remove the clamp and cut lead at the clamp. Splice by soldering a length of #16 wire, 320 mm (12-1/2”) or longer. Insulate and secure with clamp. Cut wire and apply lug at end of wire 292 mm to 317.5 mm (11-1/2” to 12-1/2”) from the clamp.

4.3 REASSEMBLY

4.3.1 ROTATING FIELD AND ARMATURE ASSEMBLY

Reassemble the rotating field and armature assembly as follows. Refer to Figure 9 on page 22 during re-assembly.

1. Apply stopwasher, item 22 of Figure 9 on page 24 , to shoulder on shaft.
2. Apply locking key (23) to keyway in shaft.
3. Apply a good grade of rust preventive grease around the shaft and up to the key (23).
4. Apply spacer sleeve (13) to shaft. Wrap outer diameter of spacer sleeve with two layers of 19-mm (3/4”) wide, glass-reinforced polyester, adhesive tape, such as Mystik 7830 or Permacel P-246.
5. Apply exciter armature (24) to the shaft by inserting the sleeved field leads through the exciter armature core and sliding the exciter armature onto the shaft and seating against the stop washer (22). Ensure sleeving of the field leads is totally within the iron core of the armature.
6. Apply Rectifier mounting assembly (25) to shaft.

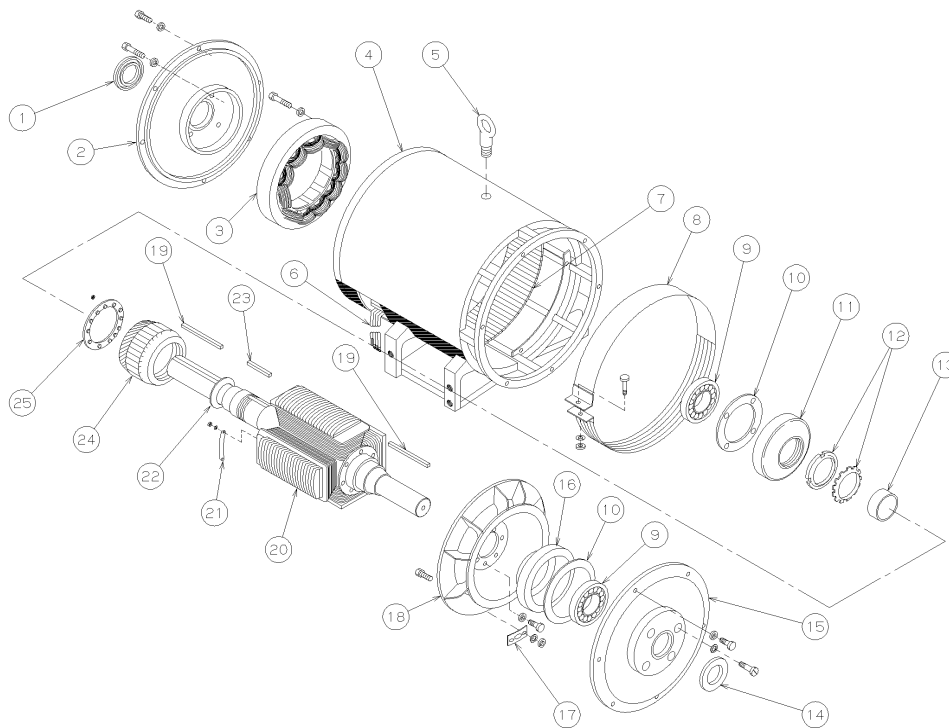

- | | |
|---------------------------------|--|
| 1- EXCITER END SEAL | 13- ARMATURE SPACING SLEEVE |
| 2- EXCITER END FRAME | 14- SEAL |
| 3- EXCITER FIELD | 15- END FRAME |
| 4- STATOR FRAME | 16- BEARING HOUSING |
| 5- EYE BOLT | 17- FAN BALANCE WEIGHT* |
| 6- EXCITER LEADS | 18- FAN* |
| 7- ALTERNATOR STATOR ASSEMBLY | 19- SHAFT EXTENSION KEY |
| 8- FAN COVER BAND* | 20- ROTATING ALTERNATOR FIELD ASSEMBLY |
| 9- BALL BEARING | 21- ROTOR BALANCE WEIGHT |
| 10- BEARING HOUSING GASKET | 22- STOP WASHER |
| 11- EXCITER END BEARING HOUSING | 23- ARMATURE LOCKING KEY |
| 12- LOCKNUT AND LOCKWASHER | 24- EXCITER ARMATURE |
| | 25- RECTIFIER MOUNTING ASSEMBLY |

*NOT ON MODEL A-8589

EE30940

Fig. 9 - Auxiliary Generator Exploded View

NOTE

Notch in bore of rectifier mounting assemblies of Model 3A/5A-8147 (2802925) and Model A-8589 (2803017) must align with key on shaft to permit proper electrical connection.

7. Bolt rectifier mounting assembly (25) to exciter armature assembly (24) using nuts removed at disassembly. Ensure studs are flat against iron core of rectifier mounting assembly. Torque nuts to 1.7 – 2.3 N•m.
8. Carefully solder all leads to proper lugs. Refer to Figure 4 on page 10. Be careful not to permit globules of solder to form, which may short out diodes. After solder has cooled, paint diode side of rectifier mounting assembly with red air-drying enamel.
9. Apply new lockwasher (12) with the twelve tangs facing outward and the one tang, which faces rearward fitting in the keyway.

10. Lubricate the threads on the shaft with light machine oil and torque locknut (12) to 373 N•m (275 ft-lbs.). If one of the twelve tangs does not line up with a slot on the nut, advance locknut so that proper engagement is possible.
11. Apply approximately 28 grams (1 oz.) of Chevron SRI-2 grease to both bearing housings as shown in Figure 10, and apply bearing housings to shaft.

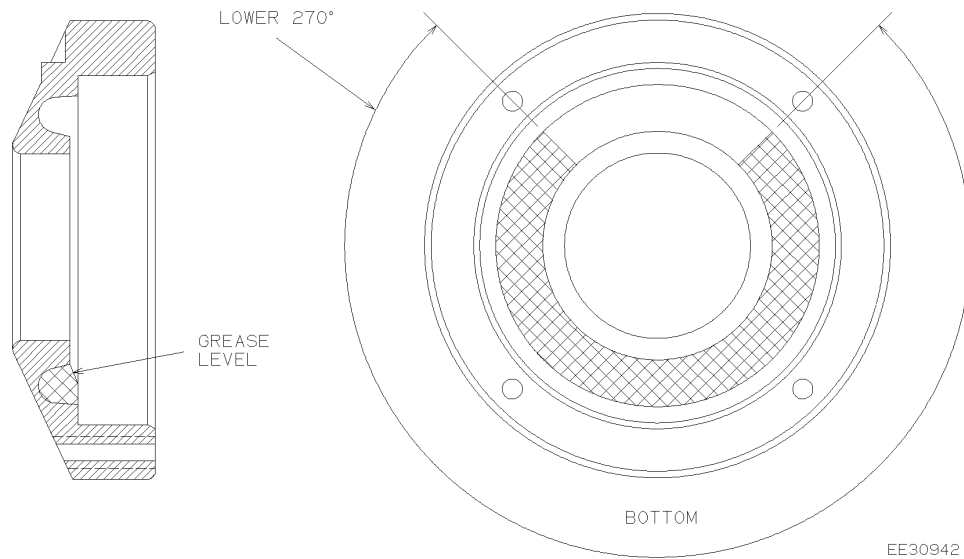

Fig. 10 - End Frame and Bearing Housing Grease

NOTE

Prior to greasing bearings, ensure bearings are clean. If coated with rust inhibitor, wash bearings with a solvent such as Stoddards Solvent.

WARNING

Provide adequate ventilation when using solvents. The usual precautions should be observed when handling inflammable fluids such as Stoddards Solvent which has a flash point of 46°C (257°F).

12. Apply 14 grams (1/2 oz.) of Chevron SRI-2 to each side of new ball bearings equally distributed between balls.

13. Apply Loctite No.601 to clean bearing seat on shaft. Slide new ball bearings over shaft. Apply pressure to inner race until ball bearings are snug against shoulder of shaft. Do not apply pressure to bearing outer race.
14. Assemble new gaskets to both bearing housings.
15. If a major component of the exciter armature and alternator field assembly required a change-out, the assembly must be dynamically balanced to within 720 mg•m (1 in.-oz.).

4.3.2 ROTOR TO STATOR FRAME REASSEMBLY

1. Apply approximately 28 grams (1 oz.) of Chevron SRI-2 grease to both end housings as shown in Figure 10 on page 23.
2. Assemble the rotor into the stator, exciter end of rotor to exciter end of stator, as follows:
 - a) Place the rotor assembly and stator assemblies on stands close enough to each other so that when a pipe extension is placed over the rotor shaft, the end of the pipe extension will protrude through the stator assembly.
 - b) Place an extension pipe over the exciter end of the shaft.

CAUTION

Protect the portion of the shaft, which will be enclosed by the extension pipe to prevent damage to shaft.

- c) With the aid of a suitable hoist, raise the extension pipe until the air gap is equal around the circumference of the rotor. With the aid of a second hoist, raise the other end of the shaft until the shaft is level.
- d) Lift and guide the rotor assembly slowly and carefully so that the insulation will not be damaged. Center the rotor within the stator.

4.3.3 END FRAMES AND BEARING HOUSINGS

NOTE

The exciter end bearing is an open, unclamped bearing. The opposite end bearing must be a clamped bearing. It is important that the proper end frame be used. Models A-8146, A-8147, A-8147-M1, end frames and stator frames have six holes for mounting end frames at both ends; 2A-8147, 3A-8147, 5A-8147, and A-8589 have six holes at the exciter end and six holes at the opposite end.

1. Bearing seals may be reused if inspected and determined to be acceptable. Refer to Figure 11 on page 26.
2. Screw a threaded rod into one bearing housing mounting hole. Rod must be long enough to extend through end frame to align bearing housing in next step.

NOTE

The use of the threaded rod into bearing housing mounting bolt hole, in the next step, aligns the bearing housing.

3. Carefully place end frames over shaft and guide threaded rod into one bearing housing mounting bolt hole on end frame.
4. Replace end frame bolts.
5. Insert three bearing housing mounting bolts and pull bearing into place with threaded rod.
6. Remove threaded rod and insert remaining bolt. Torque these bolts to 34 – 41 N•m (25 – 30 ft-lbs.). Torque end frame bolts to 34 – 41 N•m (25 – 30 ft-lbs.).
7. Replace fan cover band assembly, on units so equipped.
8. Check rotor shaft run-out at outer ends of shaft. Total indicator run-out must not exceed 0.076 mm (0.003”).

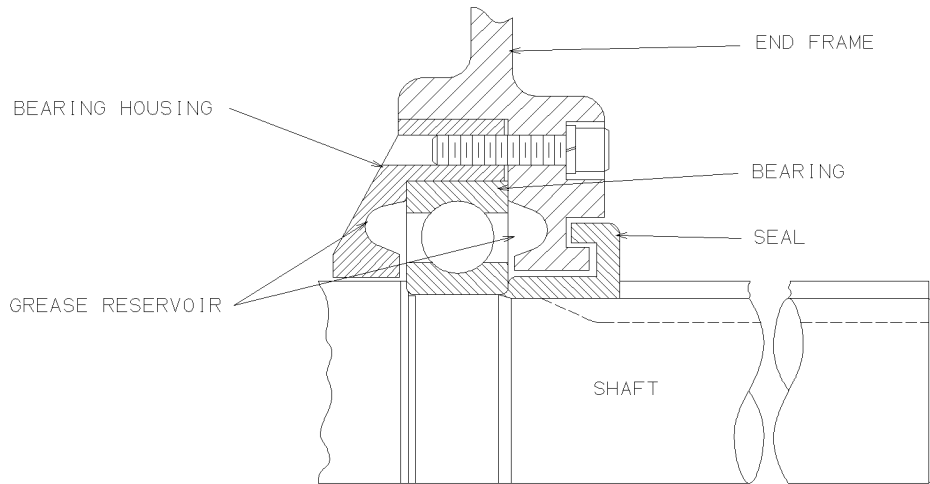

EE30941

Fig. 11 - Bearing Assembly, Cross-Section

5.0 FINAL TESTING

5.1 GENERATED RESIDUAL VOLTAGE

1. Install auxiliary generator in a suitable test stand.
2. Couple generator to a driving motor, such as an auxiliary generator with at least a 10 kW rating, operating as a motor. Rotation to be counterclockwise from the exciter end.
3. Connect auxiliary generator as shown in Figure 12 on page 30.
4. The following instrumentation or equivalent should be used. The part numbers or model numbers listed are suggestions only.
 - Driving Motor – 10 kW DC Auxiliary Generator (used as motor)
 - VM-SW Switch – Part Number 9098590
 - VM-AC Voltmeter – 0 – 60V RMS – 13/60 Digital
 - CT1, CT2, CT3 Current Transformers, 500/5 Ratio, Weston Model 1161 Type 2
 - AM-SW Switch – 9098589
 - AM-AC Ammeter – 0-5A, Weston Model 370
 - VM-DC Voltmeter – 0-75V Digital
 - CB-CKT Breaker, 6A – 9531941
 - VR Voltage Regulator VR13 – 9528076
 - CR 3-Phase Rectifier

- Power Supply, 0-15A DC, 0-60V DC, NJE Corp. Model EA 80-8
 - SH Shunt, 20A/50 mv
 - AM-F Exciter Flo Current – 0-20A/50 mv, Digital
5. Run auxiliary generator at 800 RPM and record residual voltage at no load (open circuit) RMS, line-to-line, using a digital meter. The following MINIMUM voltages MUST be achieved.

TEST	A-8146 A-8147 A-8147-M1 2A-8147	3A-8147 5A-8147	A8589
Minimum Voltage – No Load RMS, Line-to-Line	1.30	2.50	3.10

Table 8 - Minimum Voltage Values

NOTE

The residual voltage of an auxiliary generator can regress with time and can vary from machine-to-machine. It may require a “flash” of the exciter field.

6. “Flash” exciter field, if required, as follows:

CAUTION

Ensure the meters connected to measure the residual voltage are disconnected.

- a.) Run auxiliary generator at 800 RPM. Rotation to be counterclockwise from the exciter end.
 - b.) Excite the field of the exciter to 14 amps DC for 0.5 minutes with reasonable control of build-up and decay of exciting current.
7. Recheck residual voltage and note on Test Sheet that “flashing” was required. If auxiliary generator continues to fall below minimum values, reject and rework by first changing out the rotating alternator field assembly.

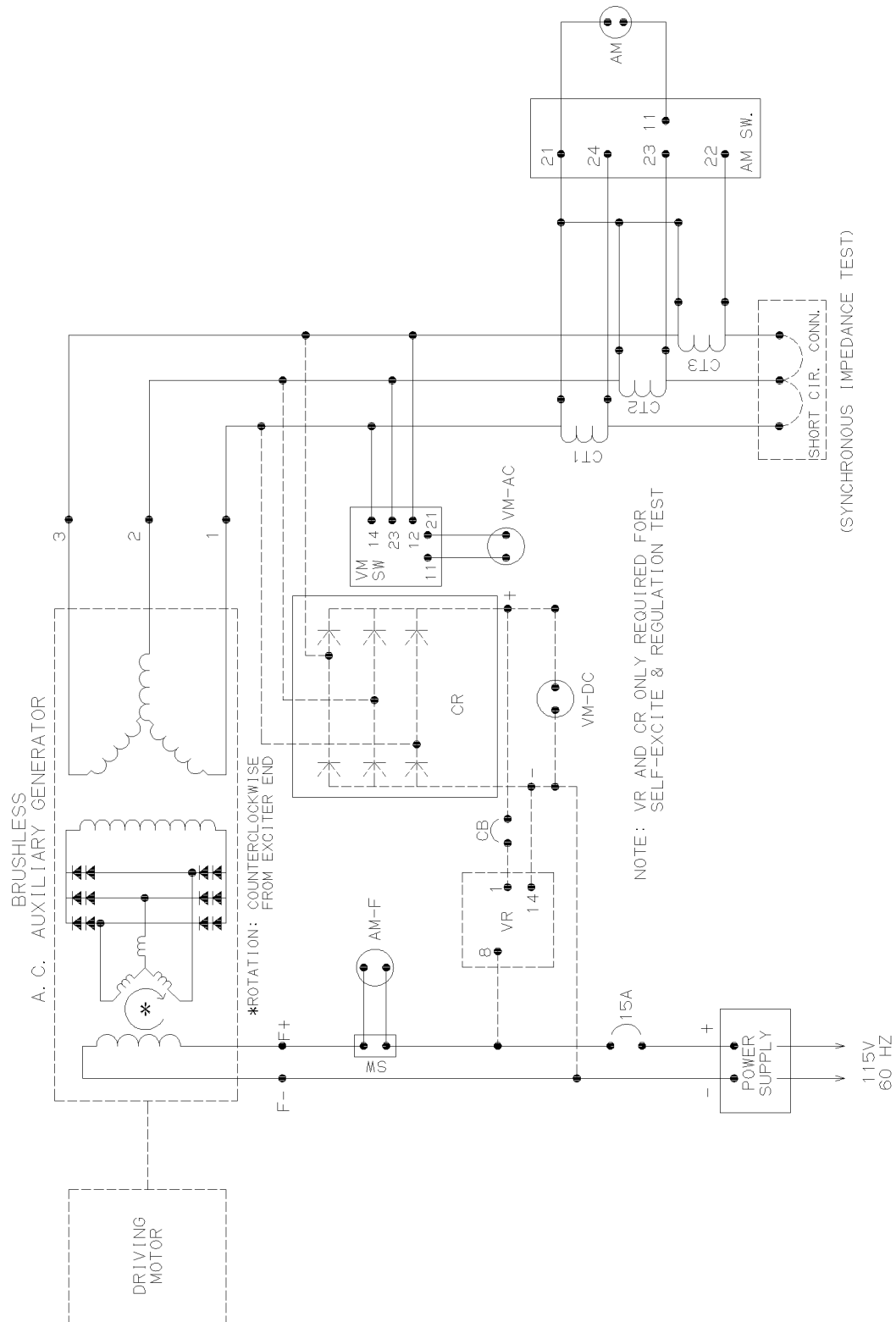

Figure 12. Test Set-Up

5.2 NO LOAD SATURATION

1. Run auxiliary generator at 800 RPM (rotation counterclockwise from the exciter end).
2. Run No Load Saturation Check at the following exciter field amps. Run at no load, RMS, line-to-line. Do not hold any one point for more than one minute. The limits are as follows:

Exciter Field Amps	A-8146 A-8147 A-8147-M1 2A-8147	3A-8147 5A-8147	A-8589
1.0	38.5-44.0	32.8-38.3	60.8-67.3
2.0	61.5-65.0	62.3-65.8	106.8-110.3
3.0	69.0-71.5	75.8-78.3	122.8-125.3
4.0	73.0-75.5	82.8-85.3	129.8-132.3
5.0	76.0-78.5	87.3-89.8	134.6-137.1
6.0	78.0-80.5	90.6-93.1	137.8-140.3
8.0	81.0-83.0	95.5-97.5	143.0-145.0
10.0	83.0-85.0	96.8-98.8	147.0-149.0

Table 9 –No Load Saturation Voltage Values

5.3 SYNCHRONOUS IMPEDANCE

1. Bolt the three phases together and run phase 1, phase 2, and phase 3 through a 500/5 current transformer.
2. Run synchronous impedance check and phase current balance by running machine to 1800 RPM. Excite exciter field to obtain 200A/Phase. Measure and record exciter field amps. Limits are as follows:

TEST	A-8146 A-8147 A-8147-M1 2A-8147	3A-8147 5A-8147	A-8589
Exciter Field Amps to Obtain 200A/Phase	1.60-1.80	3.90-4.40	2.10-2.40

Table 10 – Synchronous Impedance Test

3. Repeat Generated Residual Voltage test. “Flash” exciter field if required.

5.4 SELF-EXCITE AND REGULATION TEST

1. With auxiliary generator connected as shown in Figure 12 on page 29 run generator at 1000 RPM. Self-excitation should be apparent and 72-76 volts should be observed at output of CR.
2. Increase speed to 1800 RPM and then back to 1000 RPM. Regulation of 72 – 76 volts should be apparent with the changing of exciter field current.
3. Terminate test by opening CB and shutdown.

6.0 SERVICE DATA

6.1 REFERENCES

The following formula can be used to convert resistance under ambient (room temperature) conditions to a nominal resistance at 75°C (167°F):

$$R @ 75^{\circ}\text{C} (167^{\circ}\text{F}) =$$
$$@\text{Ambient} \times [309.5 \div (\text{Ambient T} + 234.5)]$$

Where: R = Resistance
T = Temperature

6.2 SPECIFICATIONS

Nominal Power	18/24 kW @ 0.96 PF
Nominal KVA	19
Nominal Voltage	55V AC Line-to-Line
Nominal Current	199 AC Amps
Speed Range*	608 – 2886 RPM
Frequency Range.....	20 – 96 Hz

* Auxiliary/Exciter alternator speed is 3.04 times engine speed

6.3 MATERIAL LIST

Bearing Lubricant (Chevron SRI-2, 16 kg / 35 lb Pail)	9327352
Shaft Lubricant.....	Rust Preventive Grease
Thread Lubricant.....	Light Machine Oil
Enamel, Red Air Drying (1 Gal).....	8061131
Loctite No. 601 (50 cc)	9505663
Tape, 19 mm (3/4") Glass-Reinforced, Polyester, Adhesive.....	Mystic 7830 or Permacell P-246

Document Number MM001001 (DE-LP)

Electro-Motive Division of General Motors Corporation

La Grange, Illinois 60525 USA

Telephone: 708-387-6000

Website: www.gmemd.com

©2001

Electro-Motive Division, General Motors Corporation. All rights reserved. Neither this document, nor any part thereof, may be reprinted without the expressed written consent of the General Motors Locomotive Group. Contact EMD Customer Publications Office.