



MAINTENANCE INSTRUCTION

AR10, AR12, AR15, AR16 - D14 OR D18 TRACTION GENERATOR RECTIFIER BANK ASSEMBLIES AND SUPPRESSION CIRCUITS

CAUTION

Do not perform high potential tests on diodes, either individually or collectively.

If a high potential test is to be performed on the locomotive or generator, all positive and negative generator buses must be shorted together, and the brushes at the collector rings connected together to prevent high potential from being applied to the controlled rectifier assembly SCR.

Operation of the generator without load is not recommended, and should be restricted to an absolute minimum; but under no circumstances allow no-load voltage to exceed 800 VDC, and never operate the generator with the inspection doors open or panels removed.

INTRODUCTION

NOTE

The AR11-D18 and AR11A-D18 Traction Generator Rectifier Bank Assemblies And Suppression Circuits are covered in Maintenance Instruction M.I. 3317-3.

The traction generator is a 3-phase alternator, the rotor of which makes up a 10 pole DC excited field. Two sets of "Y"-connected windings make up the alternator stator. The arrangement results in two separate sources of 3-phase AC output, each independently rectified by an assembly of heat-sink mounted silicon diodes. Two types of rectifier assembly frames are now being used. The fabricated type frame is shown in Fig. 1. The molded type is shown in Fig. 2.

Fuses are provided to isolate diodes that may become shorted, and the operating coil of a protective relay is connected across the neutral points of the stator windings to detect a single phase condition. The relay coil is also connected through resistance to ground to detect generator or locomotive grounds.

At the collector ring end of the machine, one rectifier bank assembly is to the left and the other to the right of the slip rings. Each assembly consists of:

1. A positive and a negative heat sink and bus bar assembly.
2. A mounting frame.
3. An equal number of positive base diodes and negative base diodes.
4. Interrupting fuses.

Capacitors and resistors for suppression of voltage spikes of a transient nature are located within the generator airbox, either on the airbox wall or on the generator end housing. Refer to Fig. 3 and Fig. 4.

Most models of the AR10 and all models of the AR12 and AR15 generators are equipped with current transformers mounted on the generator end plate. There are three transformers, one for phase "A," one for phase "B," and one for phase "C" at the AC side of the rectifier banks. AC current as sensed by the transformers is proportional to DC current at the main generator buses. As such, it provides a

*This bulletin is revised and supersedes previous issues of this number.
Areas of change are indicated by vertical bars in the margins.

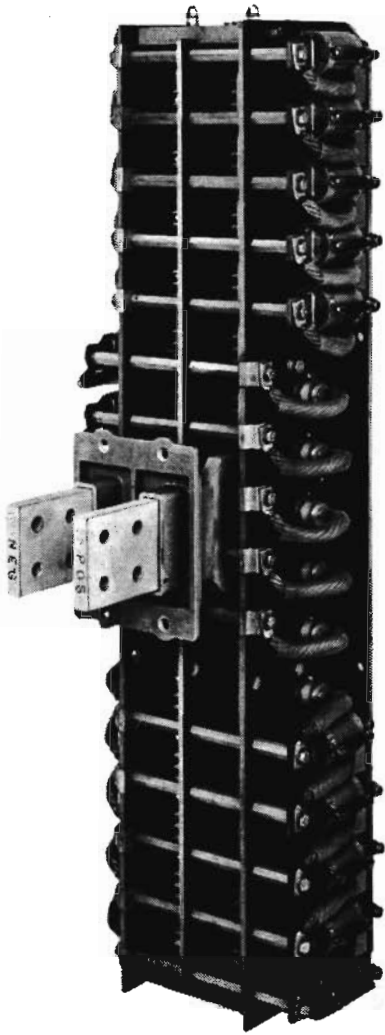

15549

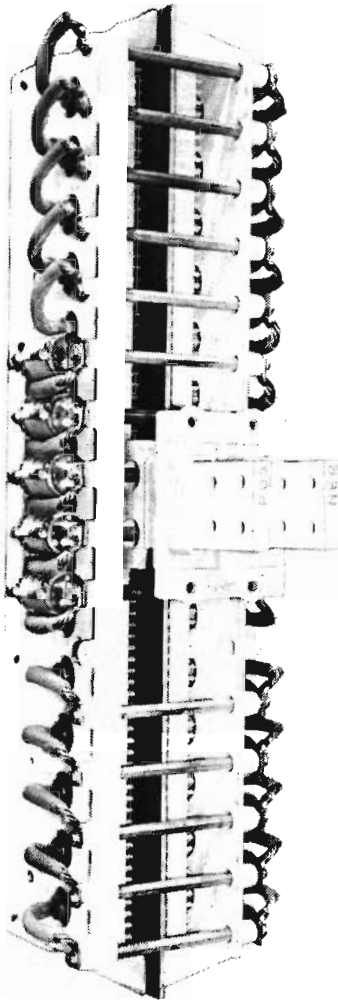

20823

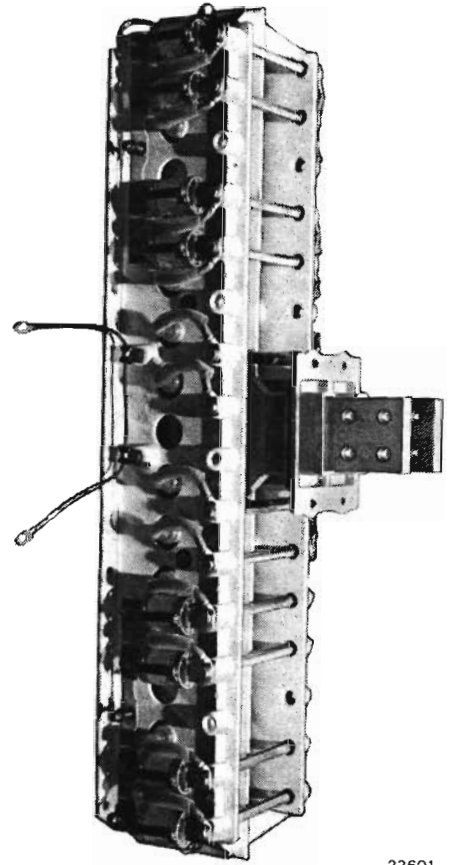

22601

Fig.1 - Fabricated-Type Rectifier Bank Assembly

Fig.2 - Molded-Type Rectifier Bank Assembly

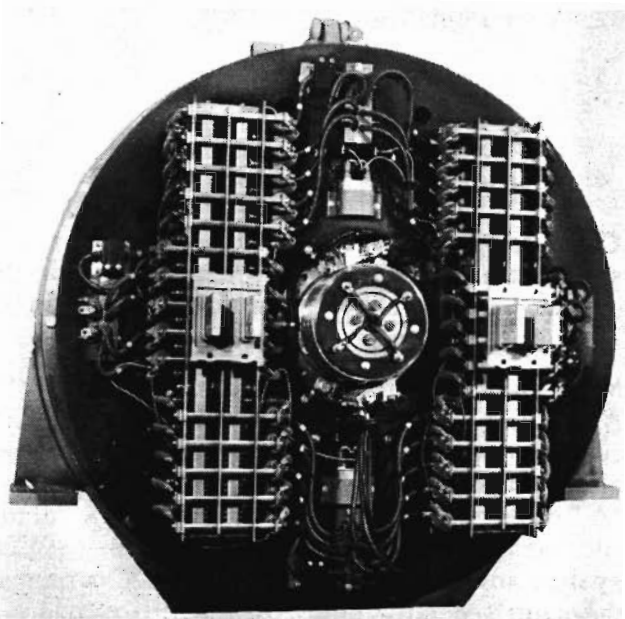

17066

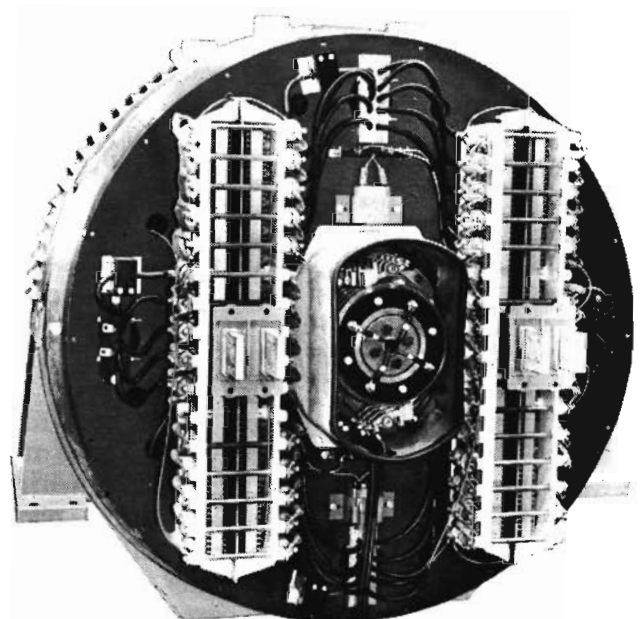

20824

Fig.3 - Fabricated-Type Rectifier Assembly

Fig.4 - Molded-Type Rectifier Assembly

signal that is proportional to DC current output from the main generator. When the locomotive control system is equipped with a performance control panel PCP or a performance control module, the generator mounted transformers, along with a cabinet mounted potential transformer, provide signals for control of generator excitation and power output. On those AR10 generators that are not equipped with current transformers, a cabinet mounted main generator field current transducer provides the necessary signals for control of generator output. The use of field current to provide a signal related to output is possible because the characteristics of the generator are such that for much of the generator operating range generator output increases directly as field current increases.

CAUTION

Some AR10 generators may be equipped with current transformers that are not used. The secondary winding of these unused current transformers must be shorted together to prevent high voltage damage to the generator.

Model AR16 generators have one larger current transformer mounted on the generator end plate. The single transformer monitors all of the AC current from phase "A" of one rectifier bank.

Refer to Figs. 5, 6, and 7 for a simplified pictorial wiring diagram of the AR10, AR12, and AR15; AR10E2; and AR16, respectively.

RECTIFIER INSPECTION

The rectifier assembly should be inspected at intervals indicated in the Scheduled Maintenance Program. Refer to Fig. 8 to inspect the rectifier assembly.

CLEANING RECTIFIER BANK ASSEMBLY

The following procedure is recommended for cleaning the rectifier assemblies. The cleaning should be performed at the intervals stated in the Scheduled Maintenance Program.

1. Remove the heat sink assemblies from the generator.
2. Remove all fuses from rectifier banks to prevent damage to fuses during cleaning operation. If there is no visible damage to diodes, diodes should be checked in heat sinks. If there is

reason to remove diodes before cleaning, inserts such as discarded diodes should be placed in diode holes to protect diode contact surface on the heat sinks. Use special diode wrench to remove diodes. Refer to Service Data for diode wrench part number.

WARNING

Water or cleaning solution allowed to contaminate the arc quenching sand inside the fuse body can cause the fuse to explode when it is required to isolate a shorted diode.

3. Mix a steam cleaner such as Dober Chemical Corporation Cleaner 6006 or Turco Chemical Company Steamfas in a suitable container. Use an 85 g per 3.79 litre (3 oz per gal) mixture of cleaner and water and maintain a tank temperature of approximately 60° C to 71° C (140° F to 160° F).

WARNING

Protect skin, and clothing while steam cleaning. Operator should always wear rubber apron, boots, gloves, and a plastic face shield.

4. Place steam gun suction pipe into the cleaning solution and regulate the gun to obtain a good soapy solution.

CAUTION

Do not use live steam alone to clean the assemblies, and do not soak the assemblies in a caustic solution. If diodes are removed from the heat sink, the contact surfaces of the diodes and heat sink assemblies must not be cleaned with an abrasive material or wire brush. Such cleaning will destroy the finish and reduce heat rejection capability.

5. Clean all parts of the heat sink assembly, keeping the gun nozzle 100 to 150 mm (4 to 6") from the work.
6. Thoroughly rinse the assembly with a low pressure stream of clean water to remove all residue.
7. Blow off remaining clean water with dry air.
8. After cleaning, the assembly should be checked for flash damage or damage caused by shorting to ground. If damage has occurred, dismantle the assembly and replace any defective parts with new parts. If no damage is found, assembly need not be dismantled.

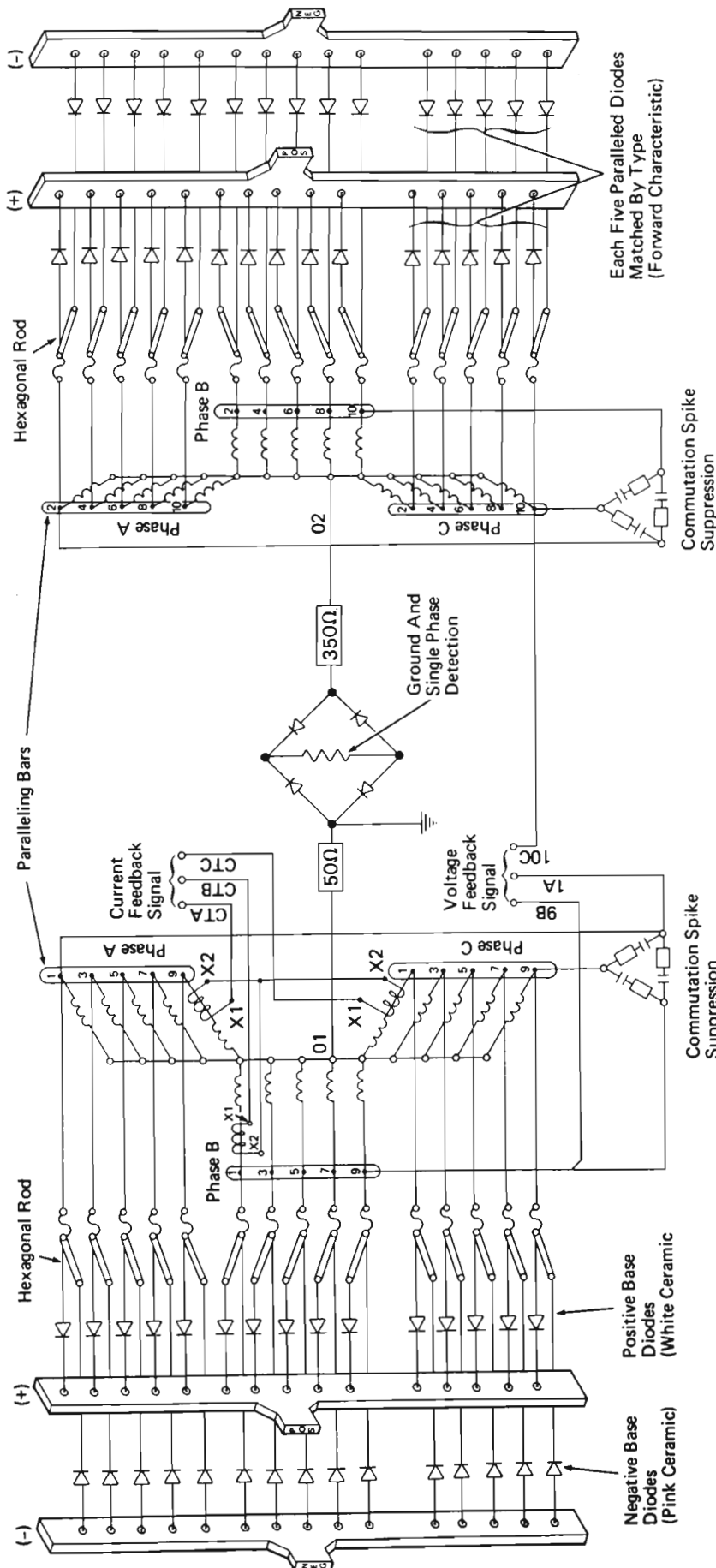

20913

Fig.5 - Simplified AR10, AR12, And AR15 Pictorial Diagram

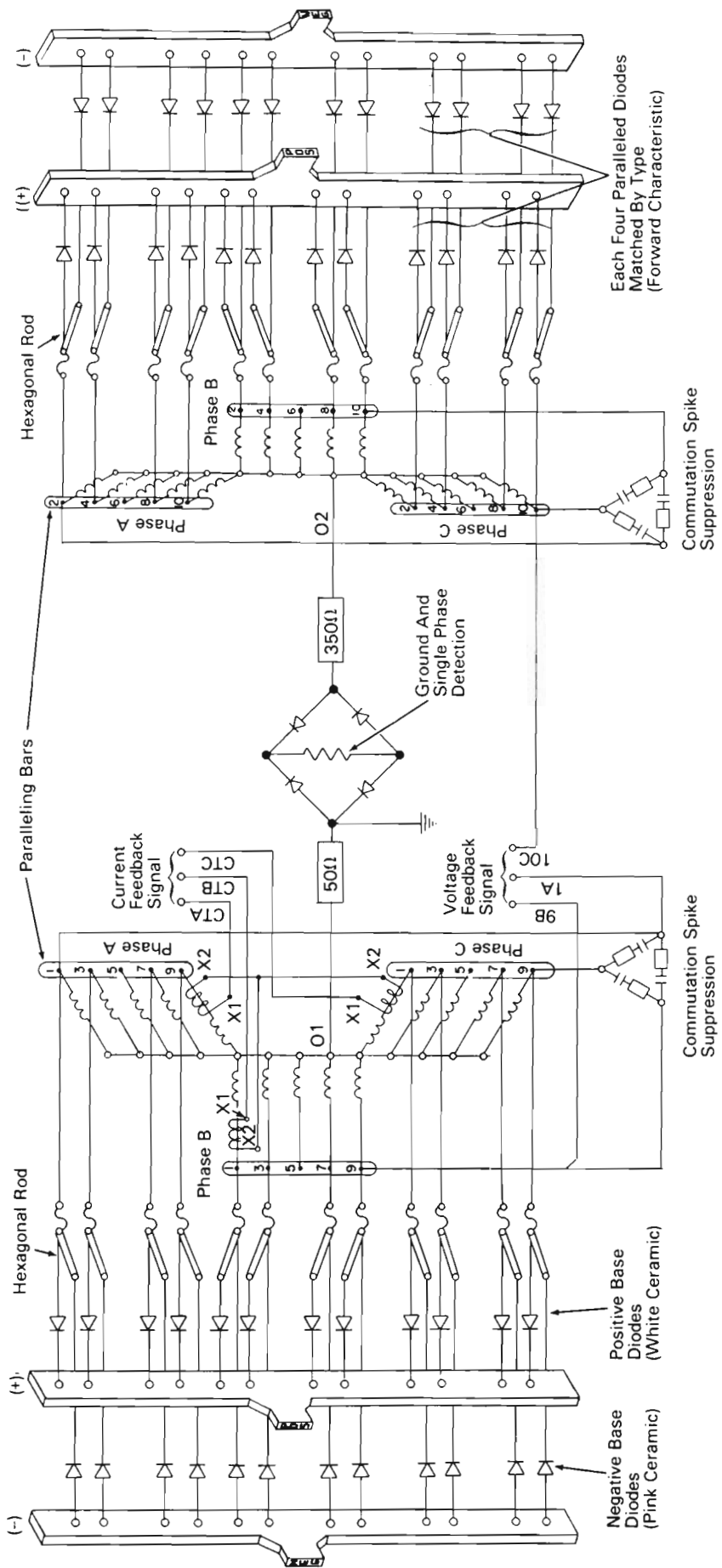

23689

Fig.6 - Simplified AR10E2 Pictorial Diagram

RECTIFIER INSPECTION

OPERATION IS PERMISSIBLE IF NO MORE THAN ONE BLOWN FUSE IS SEEN AT EACH INSPECTION PORT.

(This permits a maximum of 6 blown fuses.)

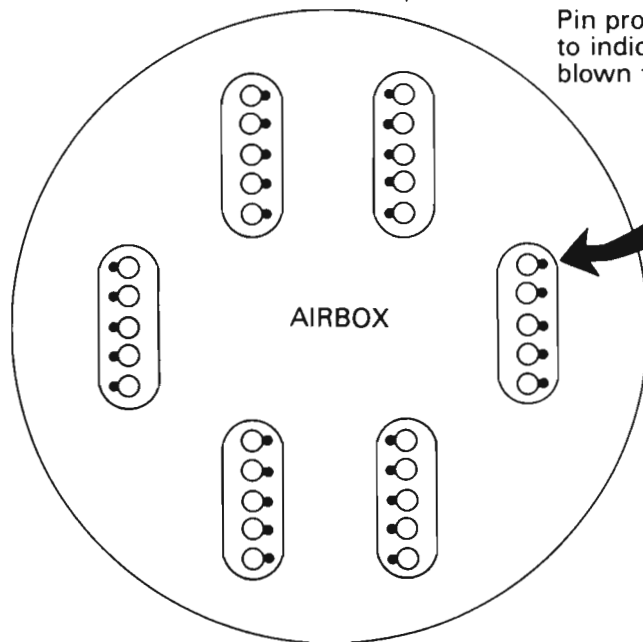

DO NOT OPERATE THE LOCOMOTIVE IF MORE THAN ONE BLOWN FUSE IS SEEN AT ANY ONE INSPECTION PORT.

(A total of 2 blown fuses may require shutdown.)

Pin protrudes to indicate blown fuse.

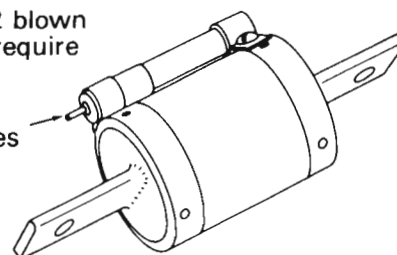

Replace blown fuses and shorted diodes as soon as practicable.

Apply all panels and covers securely after inspection.

Inspect for blown fuses and shorted diodes whenever ground relay action is reported.

NOTE

Model AR10E2 has 24 fuses (4 fuses at each port). Model AR16 has 48 fuses (8 fuses at each port).

23939

Fig.8 - Rectifier Inspection

PROTECTIVE FUSES

Current limiting fuses, Fig. 9, are provided to isolate shorted diodes. The fuses are a bolted lug type, with the lugs affixed to end blocks. Fast acting silver alloy fusible links attached to the end block are surrounded with silicon sand that acts to absorb arc energy during fault clearing. The body of the fuse is made of reinforced melamine.

A small indicating fuse is affixed to the main fuse body and is connected in parallel with the main fuse elements. When the main elements burn open, the element of the indicator also burns open. A spring in the indicator drives an indicating pin to protrude about 5 mm (3/16") from the end of the indicator.

Note that the internal-hex screw on one end of the fuse is provided only for insertion of sand by the manufacturer. The screw is staked to prevent its removal. The fusible elements cannot be renewed, and a blown fuse cannot be repaired.

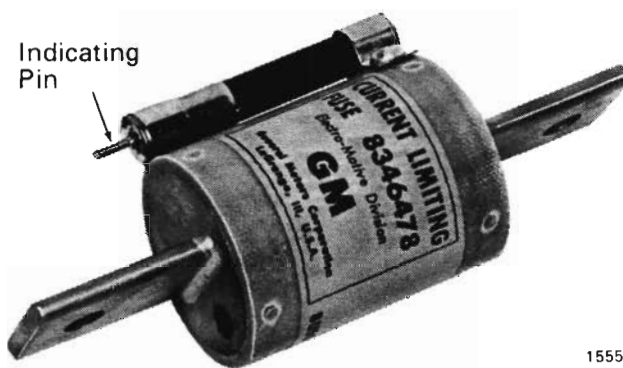

15552

Fig.9 - Current Limiting Fuse

NOTE

Two fuses with different voltage ratings are used. Models AR10X2, AR12, AR12A, AR15, and AR16 are manufactured with fuse 8407729 and the other generator models are manufactured with fuse 8346478. However, fuse 8407729 may be used as a service replacement.

DIODE INSPECTION AND REPLACEMENT

Refer to Fig. 10 for information regarding diode testing and replacement.

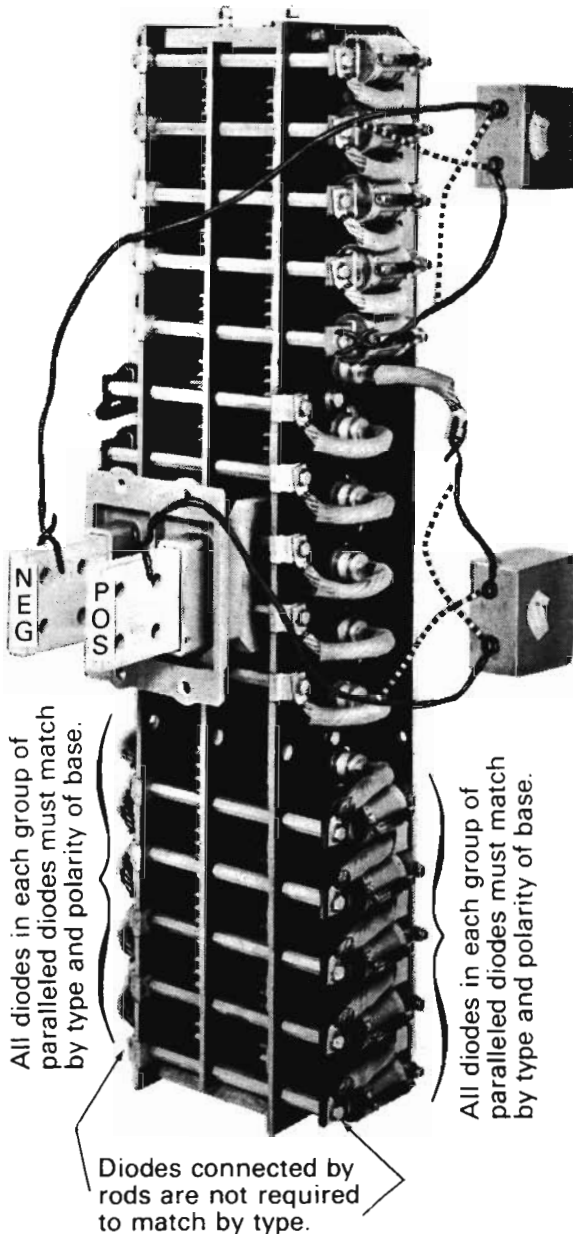

24234

DIODE INSPECTION AND REPLACEMENT

1. Indicating pin protrudes.
2. Remove bolt and unfasten diode lead. Check fuse continuity.

NOTE

If multiple failures have occurred in a single group of diodes, or if repeated failures have been observed in a single group of diodes, isolate and check all diodes in the group.

3. Place continuity tester across negative bus and connecting rod, then switch the tester leads. This checks one of the diodes.

If diode is good, the meter registers 10 to 20 ohms in one direction and above 30,000 ohms when leads are reversed.

NOTE

The 30,000 ohm value is for an individual diode isolated from the circuit. A diode not isolated from the circuit should register greater than the following values:

- AR16- 1250 ohms
- AR10E2 - 2500 ohms
- All others - 2000 ohms

4. Place continuity tester across positive bus and diode lead, then switch the tester leads. This checks the other diode.
5. Replace blown fuse with a good fuse.
6. Remove any defective diodes, using special diode wrench 8361524.
7. Wipe the diode mounting surface of the heat sink bus. Do not use abrasive material.
8. Replace defective diodes with good diodes of identical type, polarity, and voltage class (or higher voltage class). Apply a thin coating of compound 8346481 to the base of the diode hex to cover the surface. Do not apply on threads.
9. With special diode wrench and 0-50 ft-lb torque wrench, torque diodes to 34 N·m (25 ft-lbs). Make certain that the wrench is properly seated when torquing.
10. Torque diode terminal lug bolts to between 15 to 18 N·m (11 to 13 ft-lbs).
11. Replace and securely fasten all air box panels and inspection covers.

Fig.10 - Diode Inspection And Replacement

DIODE CLASSIFICATION

For service purposes the following classifications of generator diodes are significant.

1. Polarity with respect to the diode base (threaded stud). A color code is used to assist in identification.
2. Type with respect to forward voltage drop. Identification is assisted by color code and by type number impressed into the base.
3. Voltage class in respect to repetitive and non-repetitive peak inverse voltage rating. Identification is assisted by color code.

A table that relates diode service part numbers to other identifying characteristics is provided as Table I in the Service Data section of this instruction.

DIODE POLARITY

THE DIFFERENCE BETWEEN POSITIVE AND NEGATIVE BASE DIODES

The direction in which conventional electrical current flows through a diode determines its polarity. The graphical arrow symbol, Fig. 11, is oriented to indicate diode polarity.

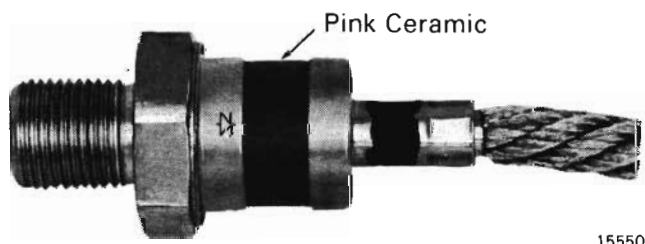

Fig.11 - Rectifier Polarity Symbol - Negative Base Diode Shown

To provide a permanent method of identification, the ceramic cases of the diodes are permanently colored as follows:

DIODE POLARITY	
Positive Base Diode	White Ceramic
Negative Base Diode	Pink Ceramic

For the diode to conduct, a positive voltage must be applied coincident with the tail of the arrow, and a negative voltage applied coincident with the point of the arrow. If the voltages are reversed, the diode will block, and only a small leakage current will pass through the diode.

Negative base diodes require a positive voltage on the stud, and a negative voltage on the flexible lead in order to conduct.

Positive base diodes require a positive voltage on the flexible lead, and a negative voltage on the stud.

DIODE TYPES

THE DIFFERENCE BETWEEN DIODE TYPES

Because of the high DC current requirements for locomotive tractive power, diodes must be connected in parallel conducting paths. When parallel operation of silicon diodes is undertaken, means must be provided to ensure a reasonable degree of current sharing. Each diode in a parallel group must share the load to prevent overloading of diodes in parallel with it.

Current sharing of generator diodes is accomplished by paralleling only diodes whose forward characteristics (forward voltage drops) are a near match.

At the time of manufacture, diodes are segregated under specific test conditions according to their forward characteristics and are assigned a type number that is permanently impressed in the metal at the flat end of the threaded stud. In addition, a color code band is applied where the flexible lead is crimped to the diode body, Fig. 12.

DIODE TYPES	
Diode Type Number	Body Crimp Color Band
1	None
2	Red
3	Black

NOTE

The Type 1 diode is not used on new equipment and is not available as a replacement part. It may, however, be used in a rebuilt generator.

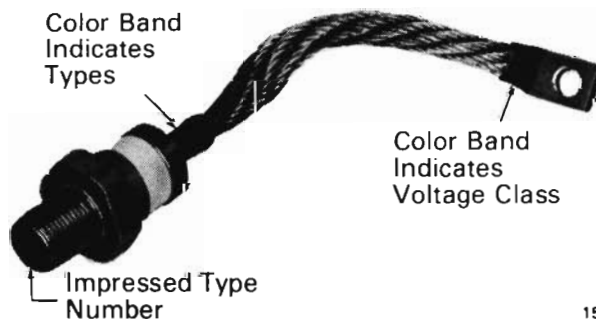

Fig.12 - Diode Type-Number And Color Bands

DIODE VOLTAGE CLASSES

Six voltage classes of diodes have been manufactured. The class identification is indicative of repetitive and non-repetitive transient peak inverse voltage capabilities under specific test conditions. A color band around the barrel at the lug end of the flexible lead indicates the diode voltage class.

DIODE VOLTAGE CLASSES	
Color Band At Lug Barrel	Voltage Class
None	1600/2000
Orange	1800/2100
Green	2000/2400
Brown	2200/2600
Blue	2200/2800
White	2200/3000

The voltage class used in a specific generator is dependent upon the type of service in which the generator is employed and upon specific characteristics of the control system that is used. Refer to Table Of Diode Identification, Table I, in Service Data section to identify diodes.

MANUFACTURER'S QUALIFICATION MARKS

A variety of qualification marks (see Fig 13) have been placed upon diodes by the manufacturer. For example; small color dots on the diode body, large color spots (not bands) on the diode body or lug, color marks at the edge of the lug, and numbers stamped onto the diode body. These marks are for manufacturer's identification only.

The only significant marks for service purposes are:

1. The color band 360 degrees around the lug barrel at the end of the flexible lead.
2. The color band 360 degrees around the crimp at the flexible lead and diode body.
3. The service part number printed on the cap of the diode body.
4. The color of the ceramic insulator.
5. The diode type number stamped into the flat end of the threaded stud.

ALL OTHER COLOR SPOTS AND STAMPINGS ARE IRRELEVANT FOR SERVICE PURPOSES AND ARE TO BE DISREGARDED COMPLETELY.

DIODE MATCHING

Fig. 14 shows an AR10 rectifier assembly with the air box removed. The illustration shows how diodes and fuses are paralleled in groups of five by use of paralleling bars.

Diodes used in the generator must be matched as follows:

1. Polarity

All diodes in any paralleled group **must** be of the same polarity (ceramic cases **must** be of the same color), and the diodes **must** be applied to the proper heat-sink bus. Negative base (pink) diodes to negative bus, and positive base (white) diodes to positive bus. Bus polarity is stamped into the end of the bus.

2. Type

All diodes in any paralleled group **should** be of the same type (same impressed type number and same type color band at the lower crimp). **MIXING OF TYPES WILL CAUSE UNEQUAL LOAD SHARING.**

Observe that hexagonal connecting rods do not connect diodes in parallel; therefore, diodes connected by rods do not necessarily **match** by type.

NOTE

Some generators are equipped with Type 1 diodes, but only Type 2 and Type 3 diodes are used in new production, and only Type 2 and Type 3 diodes may be obtained as replacement parts. If replacement for a Type 1 diode is needed, remove all diodes from the affected paralleled group and renew with Type 2 or Type 3 diodes. Test and retain all good Type 1 diodes for use as replacement parts.

If due to operating conditions mixing of types cannot be avoided, a replacement diode of the next higher type number may be used for a temporary emergency fix. This diode **should** be replaced with the proper type diode at the earliest opportunity.

3. Voltage Class

Diodes of different voltage classes may be mixed in a generator, but all diodes in any generator **must** equal or better the inverse voltage rating (voltage class) required for the particular application. For example, diodes of

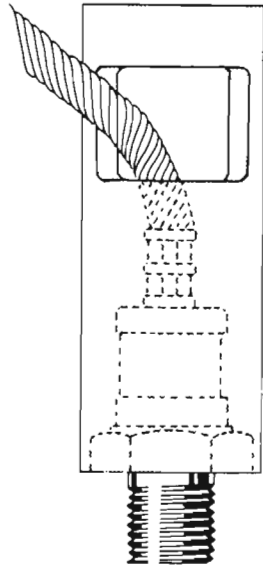

CAUTION

Make certain that socket is firmly seated. Improper seating can stress the crimped area during torquing.

Use torque wrench 8375396
 0-50 ft-lbs. 1/2" Drive
 Torque diodes to 25 ft-lbs.

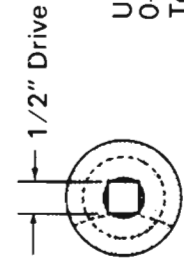

Special Diode Wrench
 8361524

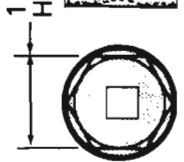

Disregard Color Marking On Very Ends Of Lugs



Silicone Rubber
 Combination
 Boot & Sleeve
 8378316

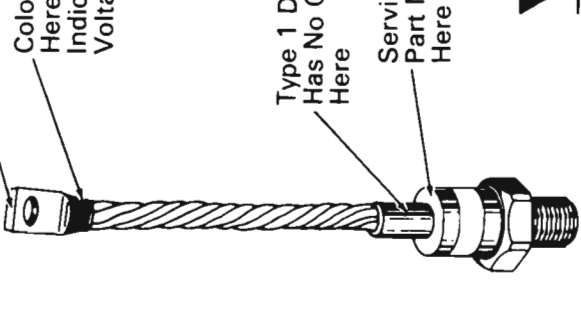
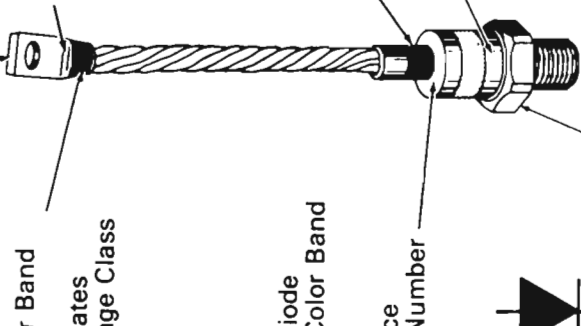
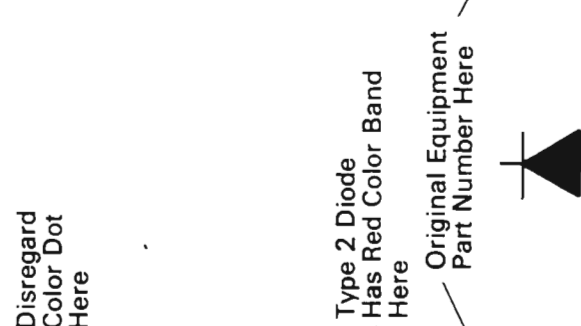
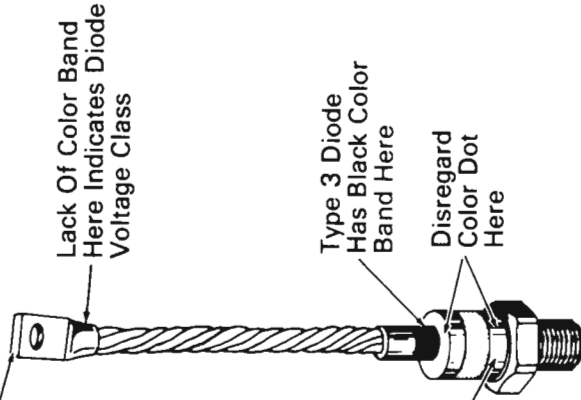

Diode Type Number
 Impressed Into
 Base Of Stud



Pink Ceramic
 Indicates
 Negative Base
 Diode



Compound 8346481 On
 Hex. Base; Not On
 Threads

White Ceramic
 Indicates
 Positive Base
 Diode



Fig.13 - Diode Identification Markings

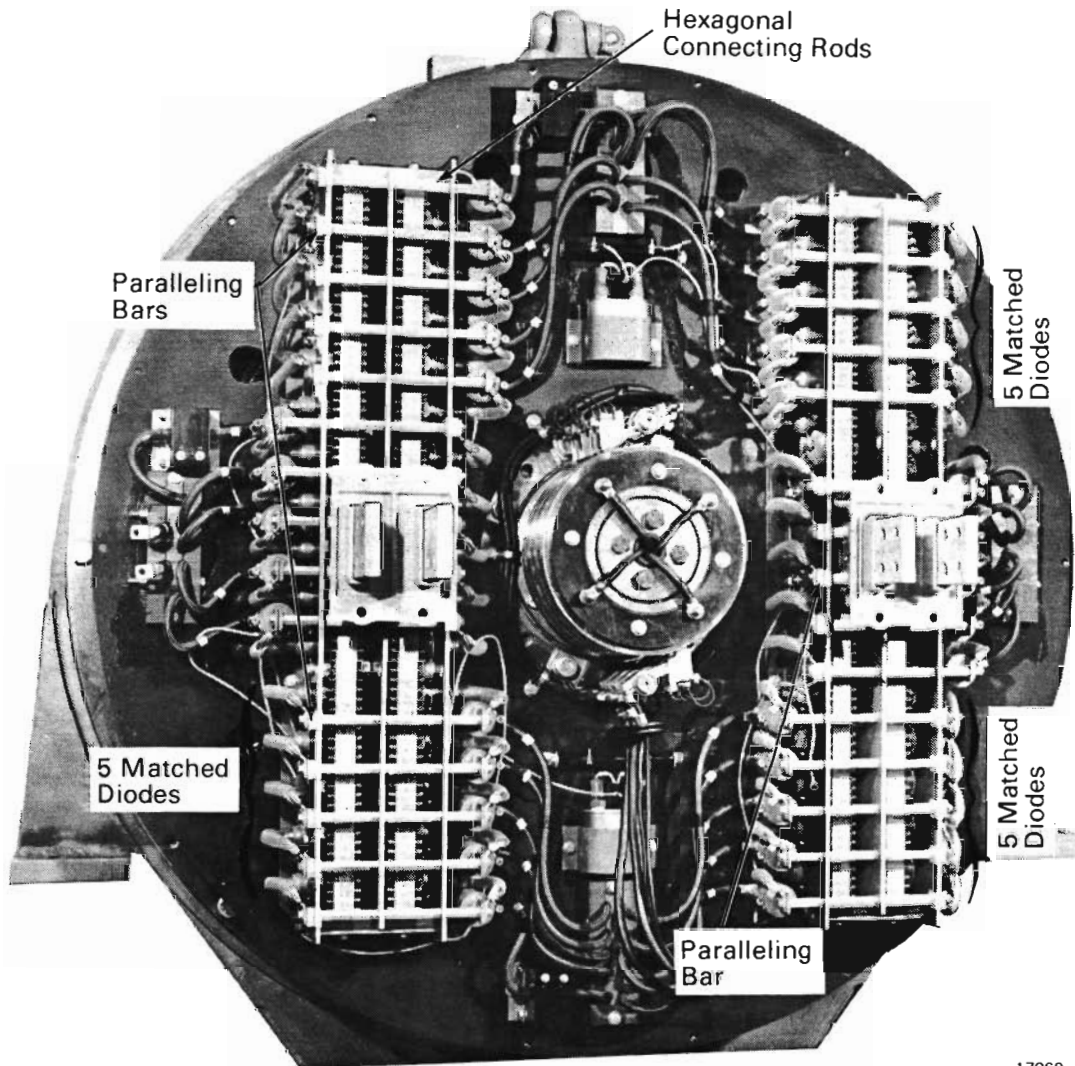

17069

Fig.14 - Diode Matching Within Groups

the 2000/2400 voltage class (green color band at upper lug barrel) may be mixed with diodes of the 1600/2000 voltage class (no color band at the upper lug) in the AR10A generator, but diodes of the 1600/2000 voltage class must not be used in the AR10B generator, because the AR10B requires diodes of a higher voltage class.

A table that relates generator model numbers to diode voltage class requirement and other pertinent data is provided as Table 2 in the Service Data section.

COMMUTATION TRANSIENT VOLTAGE SUPPRESSION

INTRODUCTION

After commutation, voltage transients are produced. The action of diodes switching from a conducting to

a blocking state in the generator is called commutation. During commutation, high reverse current flows in the diodes for a few microseconds, after which time the value of reverse current flow in the diode suddenly drops to almost zero. The rate at which current flow changes from a high value to almost zero, multiplied by circuit inductance determines the magnitude of the transient voltage spike. If this transient voltage exceeds the reverse rating of the diode, the diode will immediately fail.

The generator is provided with a system for capacitive storage of energy from circuit inductance during commutation. The system is called the commutation transient voltage suppression system.

SUPPRESSION SYSTEM DESCRIPTION

Two different suppression systems have been applied to protect the rectifiers from commutation transients. Both provide equal reliability and protection when properly connected.

WARNING

PCB (polychlorinated biphenyl) capacitors contain a toxic environmental contaminant requiring special handling and disposal in accordance with U.S. Environmental Protection Agency Regulations 40 CFR 761. For disposal information contact the nearest U.S. EPA Office.

When replacing capacitors, non-PCB capacitors should be used. PCB capacitors are no longer available as replacement parts.

Original PCB Capacitor	Replace With Non-PCB Capacitor
8380921	9332014
*8442069	*9332014
8411555	9332016
8352261	9503808

*When replacing capacitor 8442069 with capacitor 9332014, bracket 8391246 must be used.

The first of these systems, Fig. 15, uses a 4 microfarad capacitor and a 10 ohm resistor connected in series and parallel with each group of five diodes. Thus, since the DC buses are paralleled, there are 12 series resistor-capacitor circuits connected in parallel with diodes.

The second system, Fig. 16, for suppression of commutation transients uses a 2 microfarad capacitor and a 5 ohm resistor connected in series. These in turn are connected between the "A," "B," and "C" phase paralleling bars on both the left and right banks of the generator.

INSPECTION OF THE SUPPRESSION SYSTEM

An inspection of the commutation transient voltage suppression system should be made every time a faulty or failed diode is detected and replaced. The required inspection is basically visual. The following checks should be made.

1. Check that all connections are tight and are electrically correct.

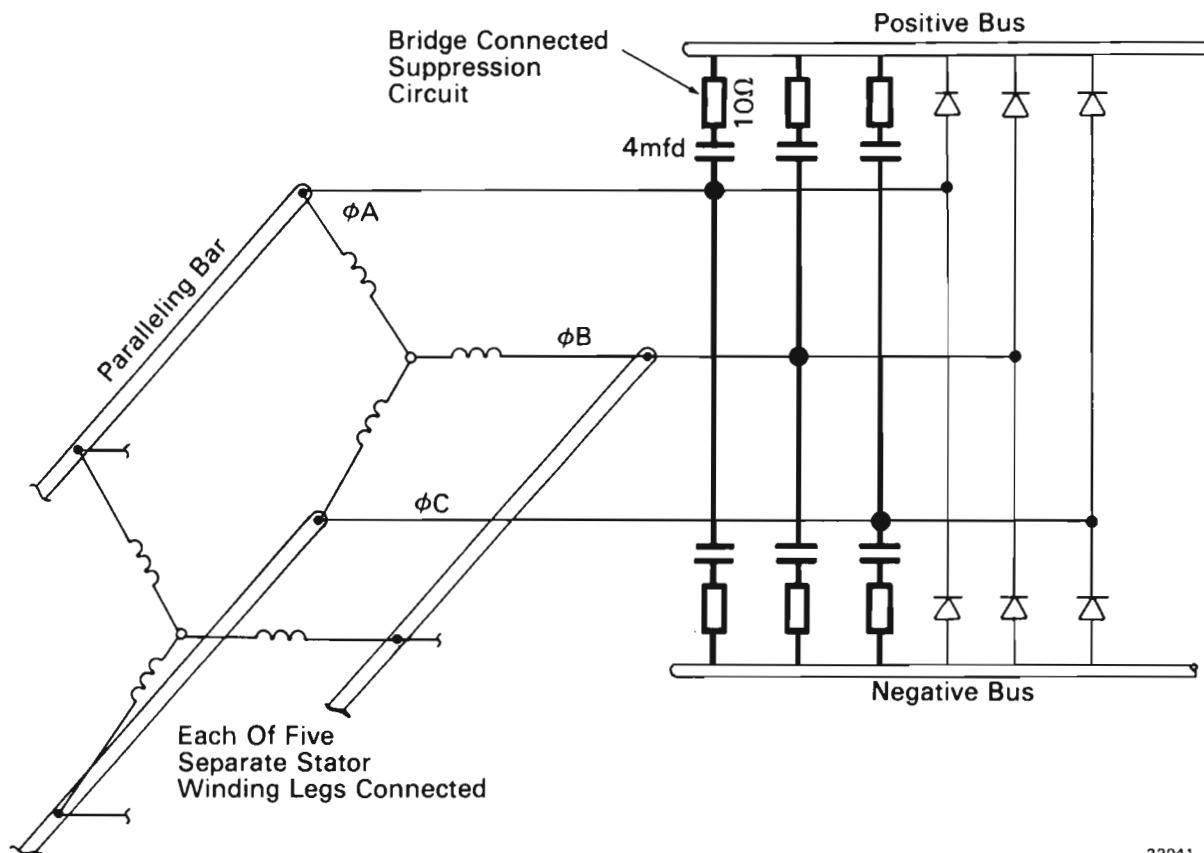
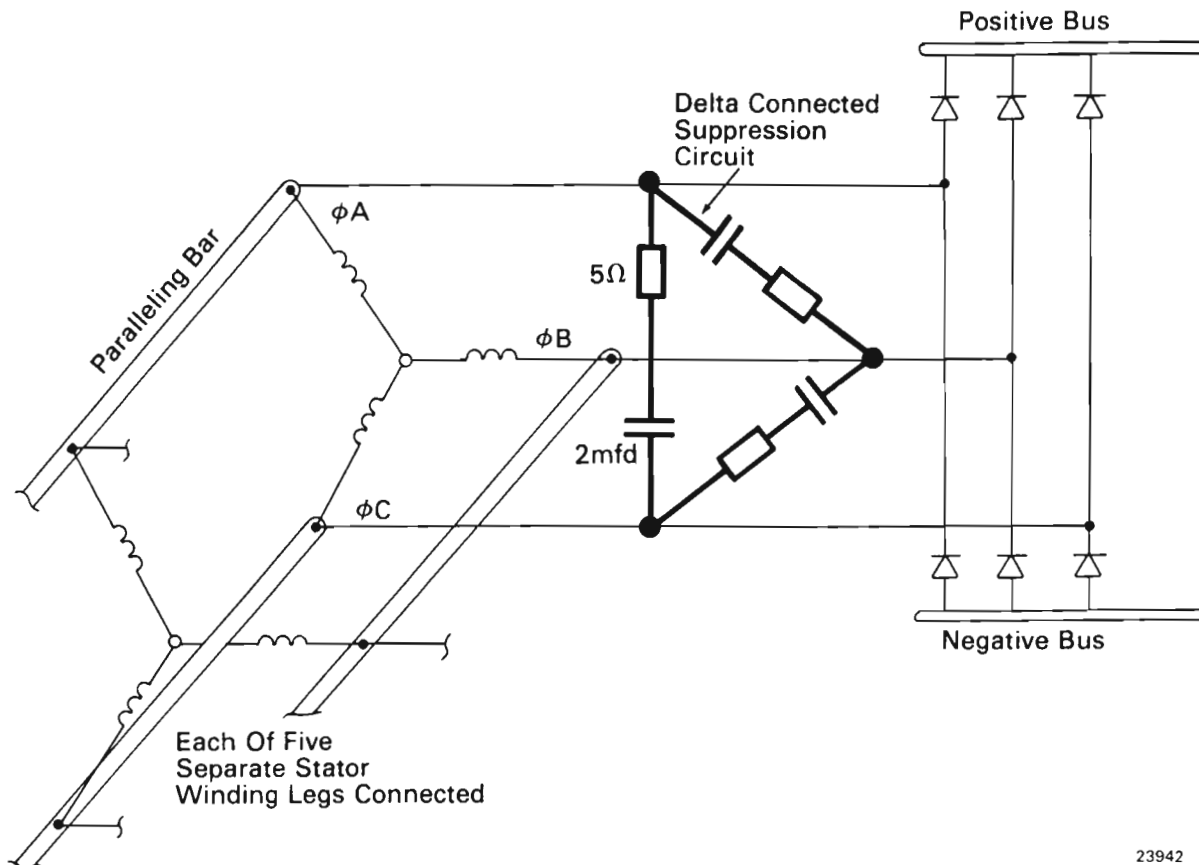

Fig.15 – Bridge Connected Suppression Circuit, Simplified Diagram

23941



23942

Fig.16 - Delta Connected Suppression Circuit, Simplified Diagram

2. Examine all resistors for evidence of overheating and open turns.
3. Examine all capacitors for oil leaks or deformation of the container. (The container top may be badly pushed out.)

TEST AND CORRECTIVE MEASURES

LOOSE OR IMPROPER CONNECTIONS

Tighten any loose connections in accordance with the applicable wiring diagram.

DAMAGED RESISTORS

Any resistors that appear to be burned or damaged should be disconnected and continuity checked. Faulty resistors must be immediately replaced with qualified resistors.

DEFECTIVE CAPACITORS

If a capacitor is suspected faulty, it should be disconnected and checked in the following manner.

1. Checks with a 500 or 1000 volt megger.
 - a. Short circuit the capacitor terminals and connect the positive lead from the megger to the terminals. Connect the megger negative lead to the capacitor case, and rotate the megger handle. The reading should be 25 megohms or more. Disconnect the megger and shorting jumper.
 - b. Connect one megger lead to one capacitor terminal and connect the other megger lead to the other capacitor terminal, and rotate the megger handle. If the capacitor is good, there will be a definite meter needle deflection

toward zero (indicating capacitor charging current) followed by a drift toward infinity as the capacitor charges. Failure of the meter needle to deflect toward zero is an indication that the capacitor is open internally.

If the capacitor is shorted, the megger will indicate zero when the megger handle is rotated. If the capacitor is open, it will indicate infinity immediately upon rotating the handle, and the reading will drop to zero when the rotation of handle is stopped.

CAUTION

Carefully discharge the capacitor after the check by using a screwdriver with an insulated handle to short across the capacitor terminals.

2. If only a 500 volt megger is available, and megger checks indicate a good capacitor but the condition of the capacitor is still suspect (burn spots appear on resistors associated with the capacitor), use a 64 VDC input, 1200 VDC output MG set as a high potential tester to induce possible flashover within the capacitor.
 - a. Connect the positive output lead from the MG set to one terminal of the capacitor. Connect the negative output lead from the MG set to the other capacitor terminal. Connect a 0-1500 VDC meter to read MG set output voltage. Connect MG set input to a 64 or 74 VDC source.
 - b. Advance MG set output voltage. The meter needle will advance as the MG set handle is rotated. If a flashover is induced in the capacitor, the meter needle will dip toward zero, indicating a bad capacitor. Immediately reduce voltage to zero, then turn off the MG set.

If the capacitor is good, voltage will remain at the high output value from the MG set. Reduce MG set voltage to zero, then turn off the set.

CAUTION

Carefully discharge the capacitor after the check by using a screwdriver with an insulated handle to short across the capacitor terminals.

GENERATOR MODELS

Several characteristics determine the particular model number given to a generator.

1. The type of suppression circuit employed, and the rating of suppression components.
2. The use or lack of current transformers.
3. The voltage class of the diodes employed.
4. Restriction as to diode type used. (Special order only.)
5. Configuration of air box.
6. Type of coupling disc employed.
7. Application of wedges at the rotor coils.

Refer to Generator Model Breakdown, Table 2 in Service Data for various model components and characteristics.

Refer to Figs. 17 through 24 for simplified wiring diagrams of Model AR10, AR12, and AR16 rectifier banks and suppression circuits.

VIEW FACING COLLECTOR RING END OF ALTERNATOR

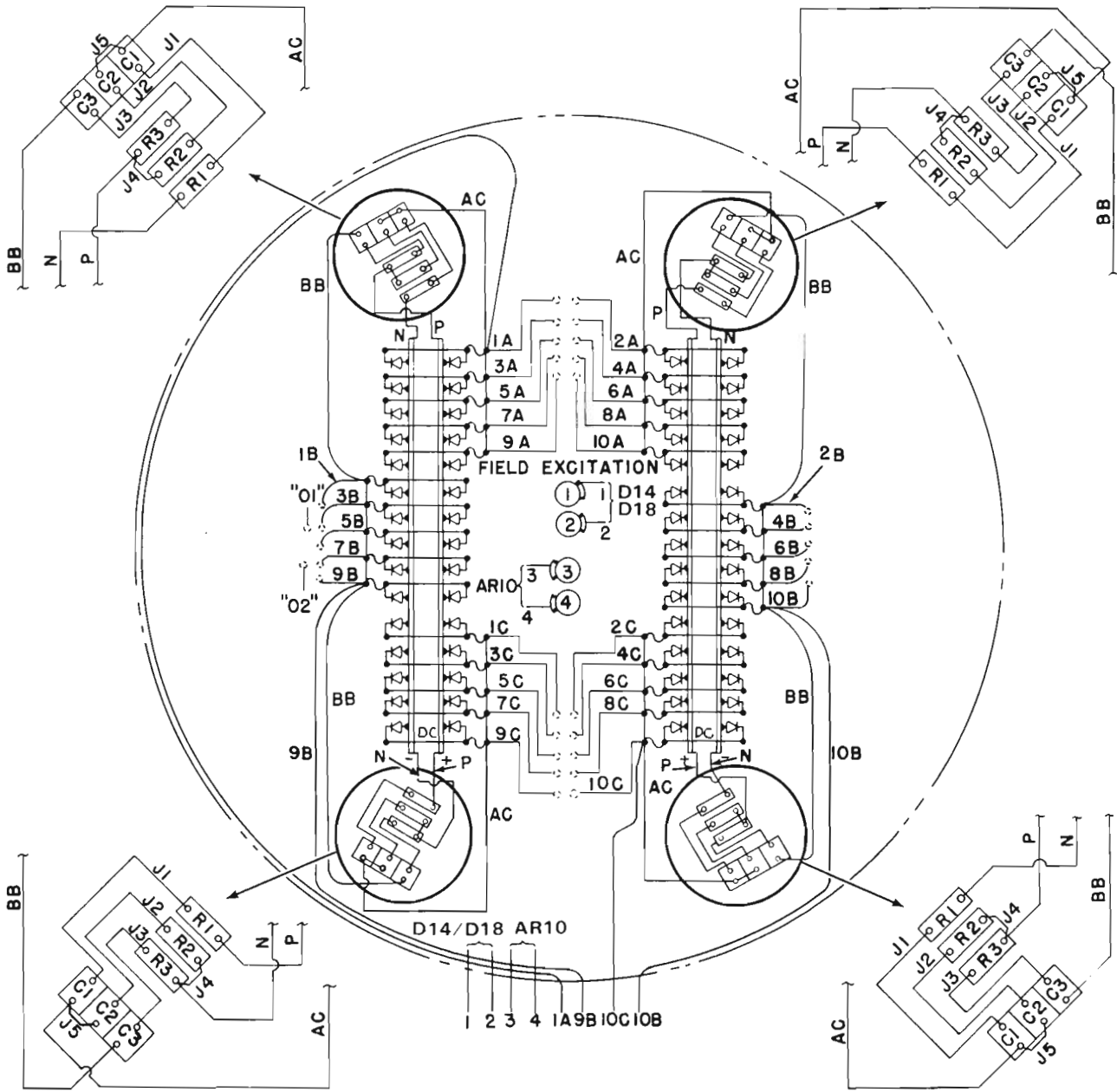

SUPPRESSION CIRCUIT COMPONENTS

- 8355837 FILTER ASSEM. - LOWER LEFT & UPPER RIGHT
- 8352224 RESISTOR BANK - R1, R2, R3
- 9503808 CAPACITOR - C1, C2, C3
- 8359406 FILTER ASSEM. - LOWER RIGHT & UPPER LEFT
- 8352224 RESISTOR BANK - R1, R2, R3
- 9503808 CAPACITOR - C1, C2, C3

27395

Fig.17 - AR10A Rectifier Banks And Suppression Circuits, Simplified Diagram

VIEW FACING COLLECTOR RING END OF ALTERNATOR

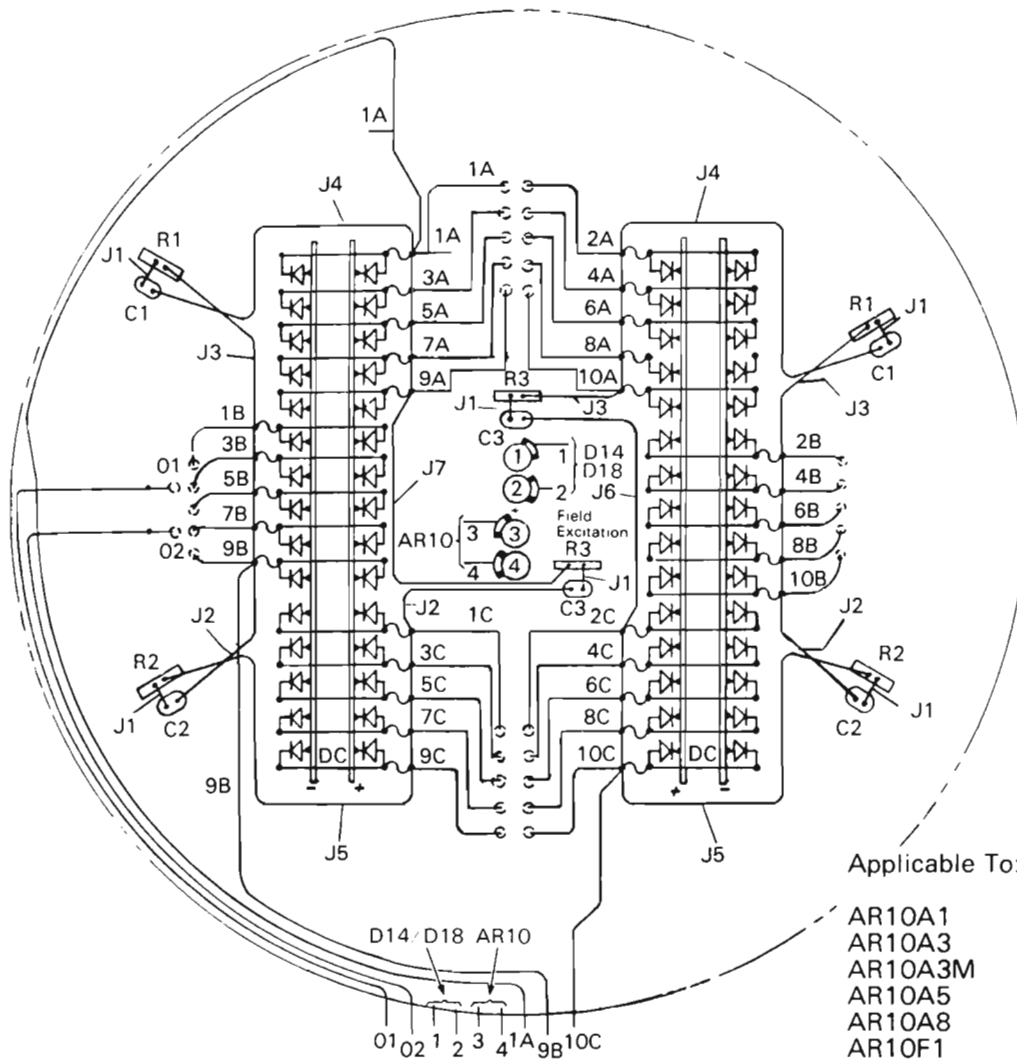

UNCONNECTED CABLE ENDS OF 1A, 9B & 10C ARE TO BE INSULATED & TERMINATED INSIDE OF AIR BOX

SUPPRESSION CIRCUIT COMPONENTS

- 9332014 CAPACITOR - C1, C2, C3
- 8380922 RESISTOR - R1, R2, R3

27396

Fig.18 - Rectifier Banks And Suppression Circuits, Simplified Diagram

VIEW FACING COLLECTOR RING END OF ALTERNATOR

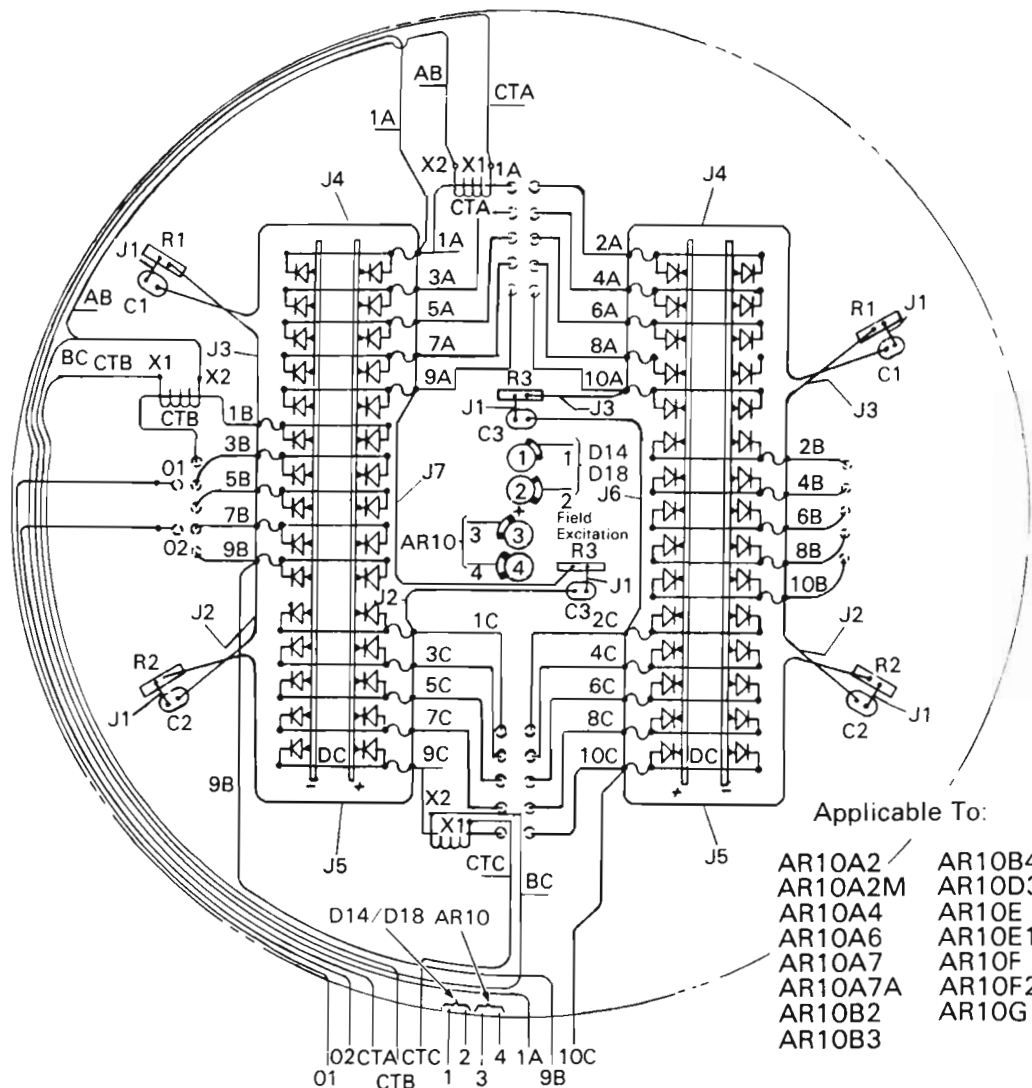

SUPPRESSION CIRCUIT COMPONENTS

- 8355837 FILTER ASSEM. - LOWER LEFT & UPPER RIGHT
- 8352224 RESISTOR BANK - R1, R2, R3
- 9503808 CAPACITOR - C1, C2, C3
- 8359406 FILTER ASSEM. - LOWER RIGHT & UPPER LEFT
- 8352224 RESISTOR BANK - R1, R2, R3
- 9503808 CAPACITOR - C1, C2, C3

27397

Fig.19 – Rectifier Banks And Suppression Circuits, Simplified Diagram

VIEW FACING COLLECTOR RING END OF ALTERNATOR

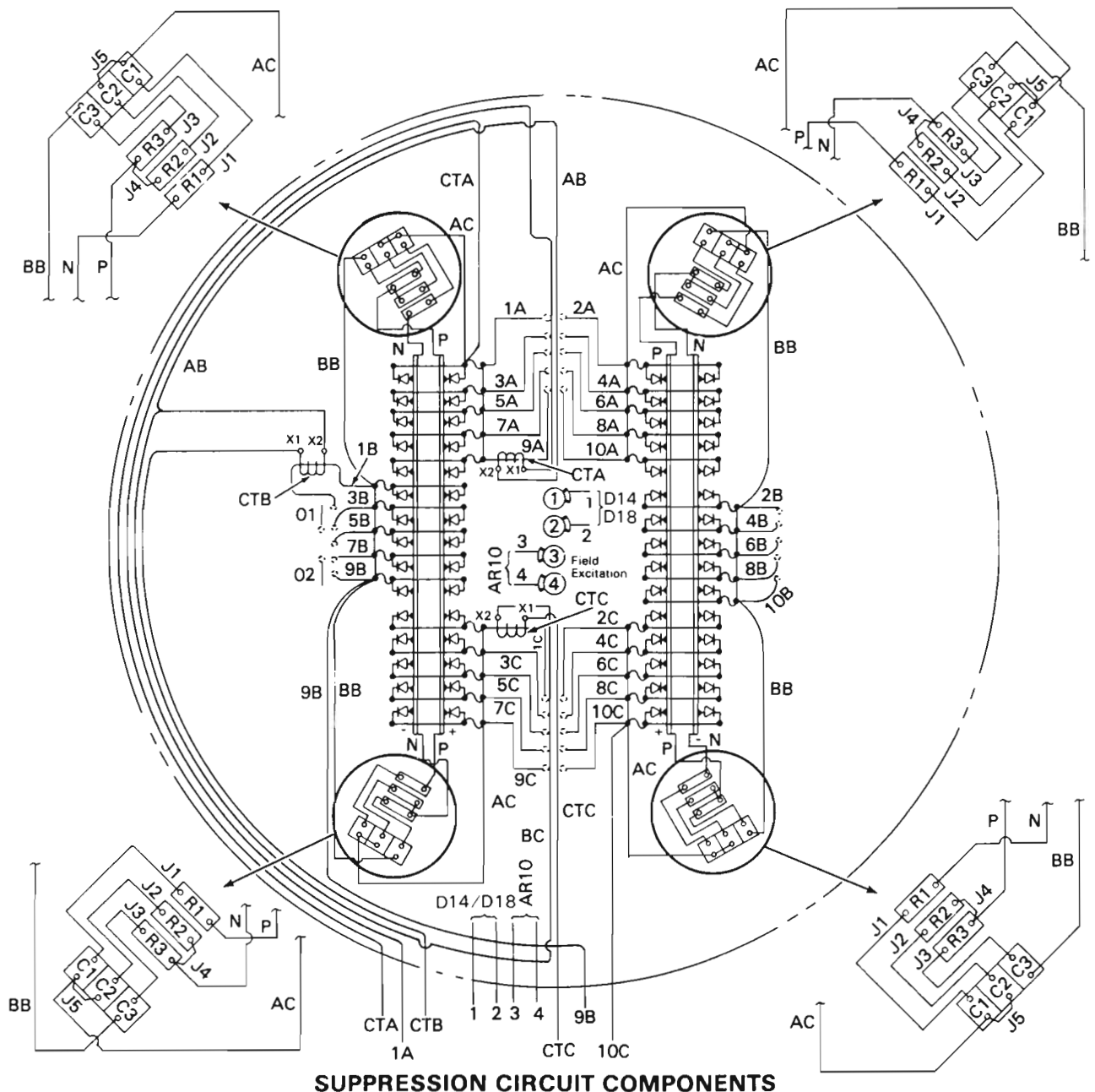

SUPPRESSION CIRCUIT COMPONENTS

- 8355837 FILTER ASSEM. - LOWER LEFT & UPPER RIGHT
- 8352224 RESISTOR BANK - R1, R2, R3
- 9503808 CAPACITOR - C1, C2, C3
- 8359406 FILTER ASSEM. - LOWER RIGHT & UPPER LEFT
- 8352224 RESISTOR BANK - R1, R2, R3
- 9503808 CAPACITOR - C1, C2, C3

27398

Fig.20 - AR10B Rectifier Banks And Suppression Circuits, Simplified Diagram

VIEW FACING COLLECTOR RING END OF ALTERNATOR

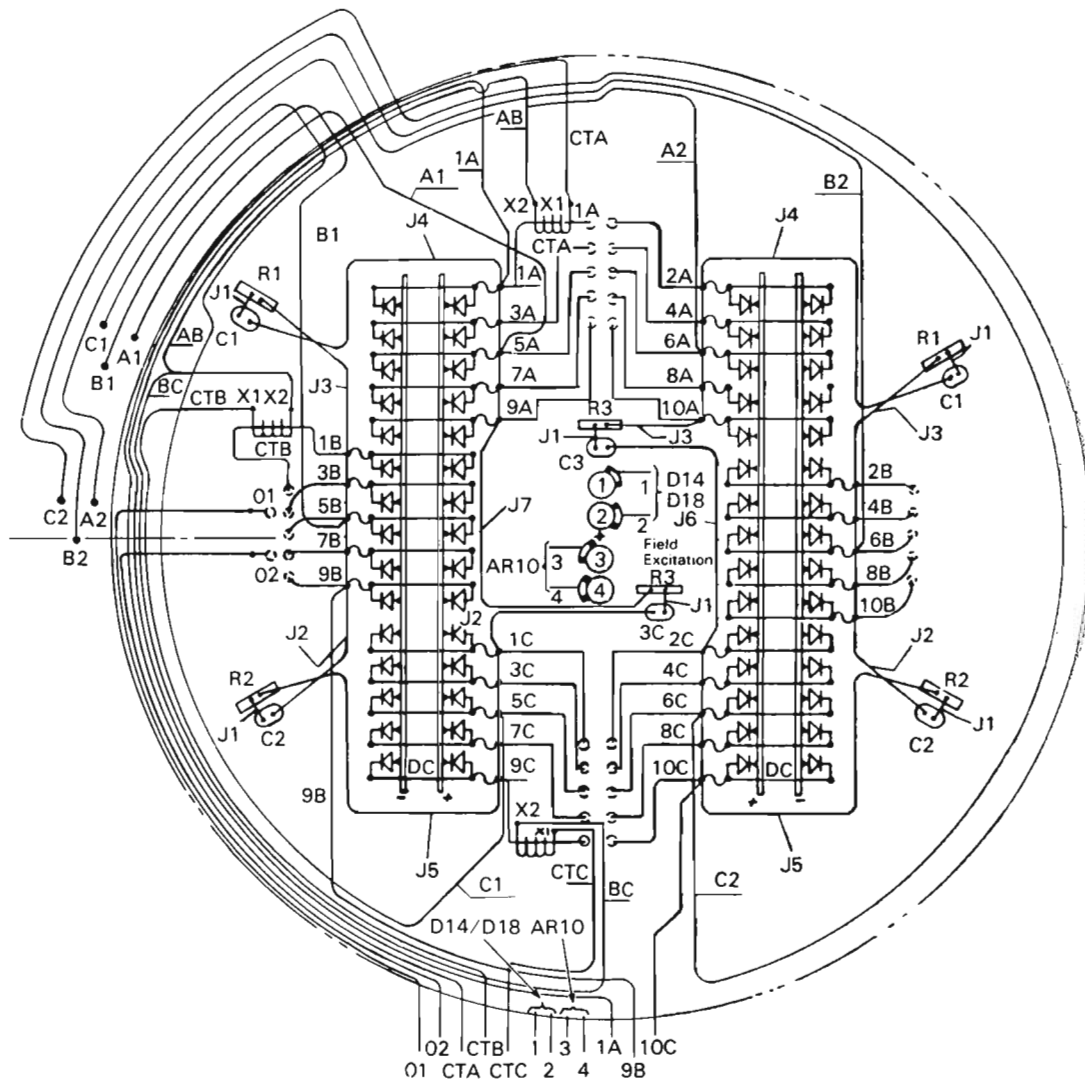

SUPPRESSION CIRCUIT COMPONENTS

8355837 FILTER ASSEM. - LOWER LEFT & UPPER RIGHT
 8352224 RESISTOR BANK - R1, R2, R3

9503808 CAPACITOR - C1, C2, C3

8359406 FILTER ASSEM. - LOWER RIGHT & UPPER LEFT
 8352224 RESISTOR BANK - R1, R2, R3

9503808 CAPACITOR - C1, C2, C3

27400

Fig.22 - AR10A7B, AR10A9 Rectifier Banks And Suppression Circuits, Simplified Diagram

VIEW FACING COLLECTOR RING END OF ALTERNATOR

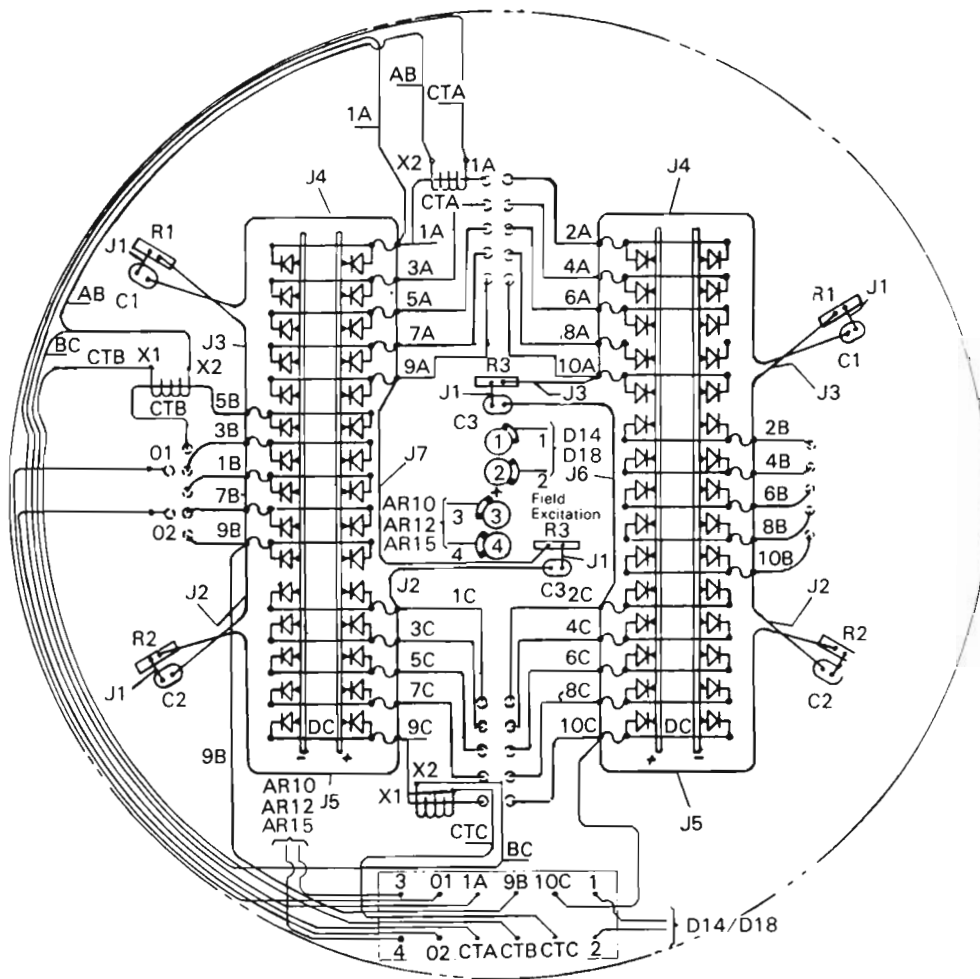

SUPPRESSION CIRCUIT COMPONENTS

8380922 RESISTOR - R1, R2, R3
 9332016 CAPACITOR - C1, C2, C3

27401

Fig.23 - AR10X2, AR12, AR12A, AR15, AR15A, Rectifier Banks And Suppression Circuits, Simplified Diagram

VIEW FACING COLLECTOR RING END OF ALTERNATOR

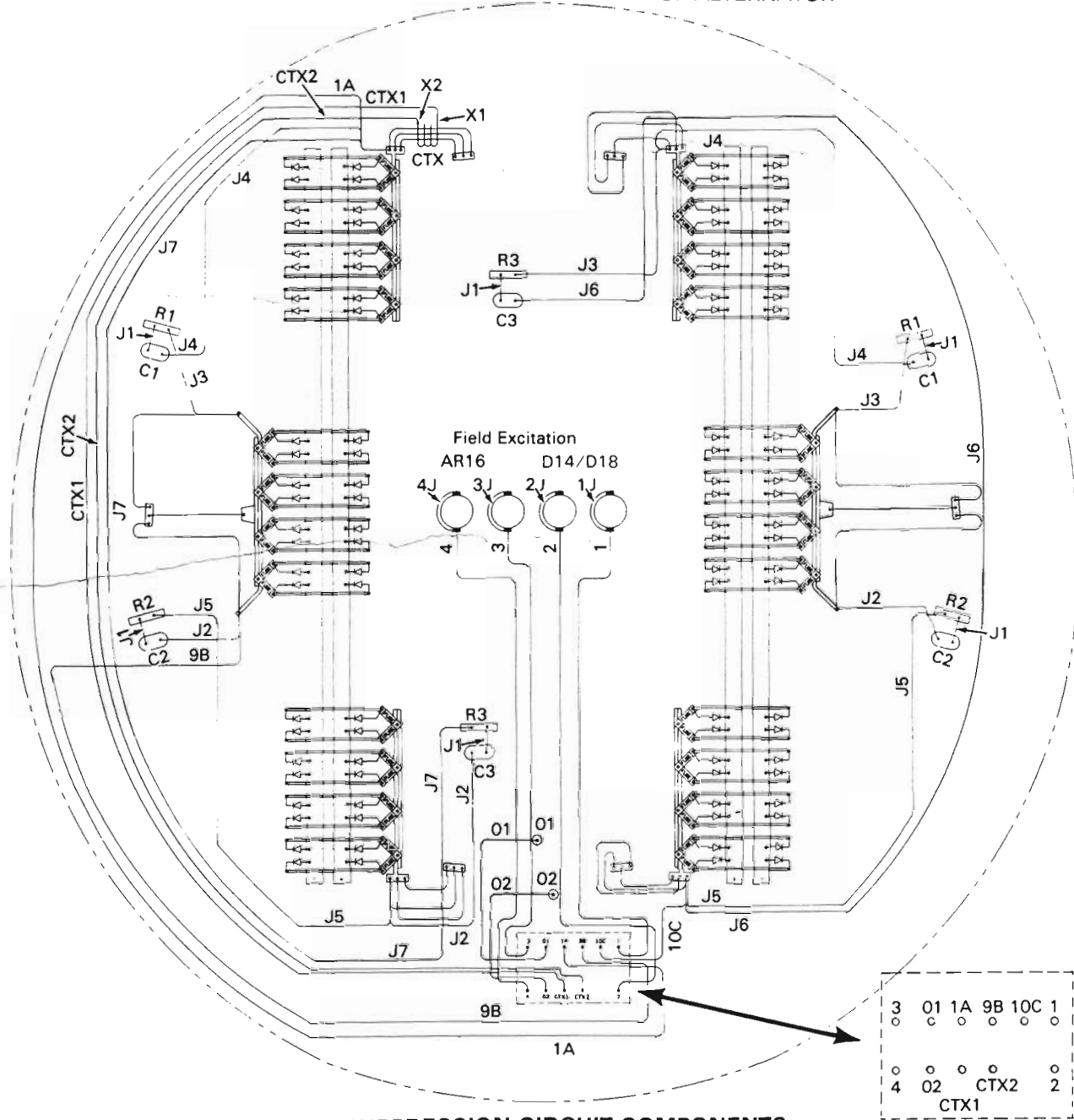

SUPPRESSION CIRCUIT COMPONENTS

8380922 RESISTOR - R1, R2, R3
 9332016 CAPACITOR - C1, C2, C3

27402

Fig.24 - AR16 Rectifier Banks And Suppression Circuits, Simplified Diagram

SERVICE DATA

SERVICE	ORIGINAL EQUIPMENT	VOLTAGE CLASS (SEE NOTE)	TERMINAL LUG BARREL COLOR BAND	POLARITY OF BASE	CERAMIC COLOR	DIODE TYPE	BODY CRIMP COLOR BAND
	8346480 8346479	1600/2000 1600/2000	None None	Negative Positive	Pink White	1, 2, or 3 1, 2, or 3	None, Red, Black None, Red, Black
8365631 8365633 8365630 8365632 8379517 8379519		1600/2000 1600/2000 1600/2000 1600/2000 1600/2000 1600/2000	None None None None None None	Negative Positive Negative Positive Negative Positive	Pink White Pink White Pink White	1 1 2 2 3 3	None None Red Red Black Black
	9330049 9330050	1800/2100 1800/2100	Orange Orange	Negative Positive	Pink White	2 or 3 2 or 3	Red or Black Red or Black
9330051 9330052 9330053 9330054		1800/2100 1800/2100 1800/2100 1800/2100	Orange Orange Orange Orange	Negative Positive Negative Positive	Pink White Pink White	2 2 3 3	Red Red Black Black
	8364555 8364554	2000/2400 2000/2400	Green Green	Negative Positive	Pink White	2 or 3 2 or 3	Red or Black Red or Black
8368468 8368466 8368469 8368467		2000/2400 2000/2400 2000/2400 2000/2400	Green Green Green Green	Negative Positive Negative Positive	Pink White Pink White	2 2 3 3	Red Red Black Black
	8427677 8427674	2200/2600 2200/2600	Brown Brown	Negative Positive	Pink White	2 or 3 2 or 3	Red or Black Red or Black
8447656 8447657 8427678 8427675		2200/2600 2200/2600 2200/2600 2200/2600	Brown Brown Brown Brown	Negative Positive Negative Positive	Pink White Pink White	2 2 3 3	Red Red Black Black
	8418232 8418231	2200/2800 2200/2800	Blue Blue	Negative Positive	Pink White	2 or 3 2 or 3	Red or Black Red or Black
8447654 8447655 8418563 8418565		2200/2800 2200/2800 2200/2800 2200/2800	Blue Blue Blue Blue	Negative Positive Negative Positive	Pink White Pink White	2 2 3 3	Red Red Black Black

NOTE

The voltage class is indicative of repetitive/non-repetitive peak inverse voltage capabilities under specific test conditions.

Table 1 - Diode Identification

Generator		Current Transformer		Diodes			Rectifier Assembly Part No.		Usage Guide For Reference Only	
Model	Part No.	Yes	No	Voltage	Type	Part No.	Neg. Pos.	Fabricated Type		Molded Type
AR10A D14	8356380		X	2000	2 or 3	<u>8346480</u> <u>8346479</u>		8357712	9084996	GP40, SD40, SDP40
AR10A1 D14	8391418		X	2000	2 or 3	<u>8346480</u> <u>8346479</u>		8357712	9084996	SD40, SDP40
AR10A2 D14	8391244	X		2000	2 or 3	<u>8346480</u> <u>8346479</u>		8357712	9084996	GP40, GP40P
AR10A2M D14	8448421	X		2400	2 or 3	<u>8364555</u> <u>8364554</u>		8364553	9084995	GP40
AR10A3 D14	8416708		X	2400	2 or 3	<u>8364555</u> <u>8364554</u>		8364553	9084995	SD40
AR10A3M D14	8449397		X	2400	2 or 3	<u>8364555</u> <u>8364554</u>		8364553	9084995	SD40
AR10A4 D14	8431191	X		2400	2 or 3	<u>8364555</u> <u>8364554</u>		8364553	9084995	GP40, GP39
AR10A5 D14	8441144		X	2400	3	<u>8368469</u> <u>8368467</u>		8448671	9084997	GT26, GT26CW
AR10A6 D14	8447750	X		2400	2 or 3	<u>8364555</u> <u>8364554</u>		8364553	9084995	GP40, GP40-2, GP39-2
AR10A7 D14	8447751	X		2400	2 or 3	<u>8364555</u> <u>8364554</u>		8364553	9084995	SD40, SD40-2, SDP40F
AR10A7 D18	9518140	X		2400	2 or 3	<u>8364555</u> <u>8364554</u>		8364553	9084995	GP40-2, SDL40-2, SD40-2, SD40T-2, GP39-2
AR10A7A D14	9099025	X		2400	3	<u>8368469</u> <u>8368467</u>		8448671	9084997	GT26CW
AR10A7A D18	9538477	X		2400	3	<u>8368469</u> <u>8368467</u>		8448671	9084997	GT26CW
AR10A7A1 D14	9507677	X		2400	3	<u>8368469</u> <u>8368467</u>		8448671	9084997	SD40-2
AR10A7B D14	9334331	X		2400	2 or 3	<u>8464555</u> <u>8364554</u>		8493244	9084998	F40PH
AR10A8 D14	8448660		X	2400	2 or 3	<u>8364555</u> <u>8364554</u>		8364553	9084995	SD40
AR10A9 D14	8493245	X		2400	2 or 3	<u>8364555</u> <u>8364554</u>		8493244	9084998	F40C
AR10A9 D18	9537757	X		2400	2 or 3	<u>8364555</u> <u>8364554</u>		8493244	9084998	F40PH-2, F40PH
AR10B D14	8364551	X		2400	2 or 3	<u>8364555</u> <u>8364554</u>		8364553	9084995	SD45, SDP45, F45, FP45
AR10B2 D14	8391417	X		2400	2 or 3	<u>8364555</u> <u>8364554</u>		8364553	9084995	SD45, SDP45, F45, FP45
AR10B3 D14	8432870	X		2400	2 or 3	<u>8364555</u> <u>8364554</u>		8364553	9084995	SD45, SDP45, F45
AR10B4 D14	8447752	X		2400	2 or 3	<u>8364555</u> <u>8364554</u>		8364553	9084995	SD45, SD45-2, F45
AR10D3 D14	9099500	X		2400	3	<u>8368469</u> <u>8368467</u>		8448671	9084997	JT22CW
AR10DF D14	9516096	X		2400	3	<u>8368469</u> <u>8368467</u>		8448671	9084997	J26CW
AR10E D14	8434954	X		2400	2 or 3	<u>8364555</u> <u>8364554</u>		8364553	9084995	GP38AC

Table 2 - Generator Model Breakdown (For Reference Only)
Continued On Page 26

Generator		Current Transformer		Diodes			Rectifier Assembly Part No.		Usage Guide For Reference Only
Model	Part No.	Yes	No	Voltage	Type	Part No. ^{Neg.} _{Pos.}	Fabricated Type	Molded Type	
AR10E1 D14	8447753	X		2400	2 or 3	<u>8364555</u> <u>8364554</u>	8364553	9084995	GP38AC, GP38-2, SD38AC, SD38-2
AR10E1 D18	9535722	X		2400	2 or 3	<u>8364555</u> <u>8364554</u>	8364553	9084995	GP38-2, MP15
AR10E1B D14	9513889	X		2400	2 or 3	<u>8364555</u> <u>8364554</u>	8493244	9084998	GP38-2
AR10E1B D18	9541206	X		2400	2 or 3	<u>8364555</u> <u>8364554</u>	8493244	9084998	F40PH-2
AR10E2 D14	9334300	X		2400	3	<u>8368469</u> <u>8368467</u>	None	9324797	SD38-2, MP15AC
AR10E2 D18	9535723	X		2400	2 or 3	<u>8364555</u> <u>8364554</u>	8364553	9084995	SD38-2, MP15AC
AR10F D14	8449914	X		2400	3	<u>8368469</u> <u>8368467</u>	8448671	9084997	GT26M, GT26CU-2, GT26MC-High Feet
AR10F D18	9535724	X		2400	2 or 3	<u>8364555</u> <u>8364554</u>	8364553	9084995	GT22-CW
AR10F1 D14	8463445		X	2400	3	<u>8368469</u> <u>8368467</u>	8448671	9084997	G22, GT22CU, GT22CW, GT26CW-2-High Feet
AR10F2 D14	9323041	X		2400	2 or 3	<u>8364555</u> <u>8364554</u>	8364553	9084995	G26CU
AR10F2 D18	9541853	X		2400	2 or 3	<u>8368469</u> <u>8368467</u>	8448671	9084997	G26CW
AR10G D14	8465673	X		2400	3	<u>8368469</u> <u>8368467</u>	8448671	9084997	G22C, GL22C, GL26C
AR10X2 D14	9321012	X		2600	2 or 3	<u>8427677</u> <u>8427674</u>	None	9320548	GP40X
AR12 D14	8417620	X		2800	2 or 3	<u>8418232</u> <u>8418231</u>	8418266	9084999	DDA40X, SD45X
AR12A D14	8431195	X		2800	2 or 3	<u>8418232</u> <u>8418231</u>	8418266	9084999	DDA40X, SD45X
AR15 D14	9321012	X		2600	2 or 3	<u>8427677</u> <u>8427674</u>	None	9320548	GP50
AR15 D18	9533507	X		2600	2 or 3	<u>8427677</u> <u>8427674</u>	None	9320548	GP50, GP50T, GP49
AR15A D14	9526354	X		2800	2 or 3	<u>8418232</u> <u>8418231</u>	8418266	9084999	GP50
AR15A D18	9534241	X		2800	2 or 3	<u>8418232</u> <u>8418231</u>	8418266	9084999	—
AR16 D14	9335776	X		2400	2 or 3	<u>8364555</u> <u>8364554</u>	9335431	9513862	SD40-2(SS), SD40X
AR16 D18	9512743	X		2400	2 or 3	<u>8364555</u> <u>8364554</u>	9335431	9513862	—
AR16A D18	9530070	X		2400	2 or 3	<u>8364555</u> <u>8364554</u>	9535431	9513862	—

Table 2 - Generator Model Breakdown (For Reference Only)
Continued From Page 25

SPECIFICATIONS

Weight Of Rectifier Bank Assembly (Approximate)

AR10, AR12, AR15	45 kg (100 lbs)
AR16	82 kg (180 lbs)

EQUIPMENT LIST

	<u>Part No.</u>
Special Diode Socket 1-17/64" Hex	8361524
Torque Wrench 0-50 Ft-Lbs - 1/2" Drive	8375396
Compound - Joint	8346481
Multimeter	8276478
Megger Tester, 0-200 megohms at 500 VDC	8174880
Leads, 3.7 m (12 ft)	8174878
Carrying Case	8174879
Dynamotor (MG Set) 1200 VDC Output - 64 VDC Input	8233558

• • • • **A Service Department Publication** • • • •

Electro-Motive Division Of General Motors La Grange, Illinois 60525

