

**ALIGNMENT OF ROTATING EQUIPMENT****GENERAL ALIGNMENT**

The purpose of aligning connected machines is to eliminate all unnecessary stresses in the shafts and couplings. Accurate alignment of coupled shafts of all types of rotating equipment is very important and must be maintained in order to assure trouble-free operation. Misalignment causes vibration, bending of shafts and unequal bearing loadings.

In addition to shaft alignment, other factors must be considered when installing equipment, which depend on the specific equipment. For example, in motors and generators, rotors must be correctly located in the stators to provide freedom of operation. Equal in importance is the positioning of the stator to the rotor radial clearance or air gap equalization. Also, bearings must be located so as to provide clearance for longitudinal shaft expansion, and end play which does not restrict normal positioning of the rotor during operation. Limiting dimensions governing these factors are given in this instruction covering the particular piece of equipment.

At the time of original installation, the preceding factors of alignment are applied to correctly align the equipment, and the various items are securely fastened and doweled to their base to maintain their correct position.

It is important to remember that it is the shafts of connected machines that require

alignment, not the couplings. Coupling surfaces may be inaccurate and not at right angles to the respective shafts. Misalignment of the shafts may be radial or angular or a combination of these two.

Radial misalignment, Fig. 1, is indicated when the centers of the two shafts do not coincide. In addition to causing excessive vibration, this radial displacement also causes the two halves of the coupling to move radially in respect to each other. This movement results in excessive wear within the coupling. Radial displacement shortens bearing life by causing pulsating loads on the bearings. The magnitude of the pulsating load will depend upon the resistance of the coupling to radial movement.

Angular misalignment, Fig. 1, is indicated by the two shafts coming together at a slight angle. In addition to causing vibration, depending upon the type of coupling,

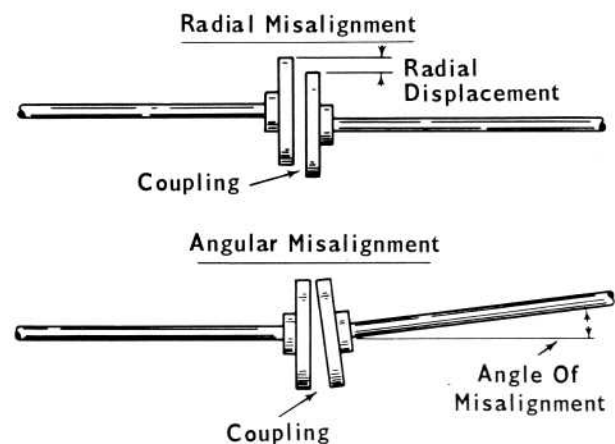

Fig. 1 — Radial And Angular Misalignment

14882

\*This bulletin is completely revised and supersedes previous issues of this number.

angular misalignment causes bending stresses to be set up in the shafts, plus additional bearing loads. The amount of stress set up depends upon the resistance of the coupling to bending.

The method of alignment will vary with the number of bearings on each shaft and the type of coupling used.

In general, where each shaft to be coupled has more than one bearing, a coupling must be used which will tolerate some angular and radial displacement. This is important since it is almost impossible to secure absolute alignment between two shafts carried in separate housings. The fact that such a coupling is used is no excuse for not aligning the shafts as accurately as possible.

When two shafts are to be coupled together and one has two or more bearings and the other one has a single bearing, a coupling must be used which does not have radial flexibility. Such a coupling must, however, be provided with angular flexibility. An example of this type of coupling is used between the diesel engine and the single bearing generator. If two mating surfaces on each half of the coupling are coupled together and are concentric with their respective shafts, the shafts will be in radial alignment, and it will only be necessary to check angular alignment. However, in the case of generators, the rotor, stator, and bearing positions must be adjusted.

Three possible methods to check shaft alignment are shown in Fig. 2. These methods respectively are:

1. Straight edge and thickness gauge
2. Dial indicator and micrometer
3. Recommended method using two dial indicators

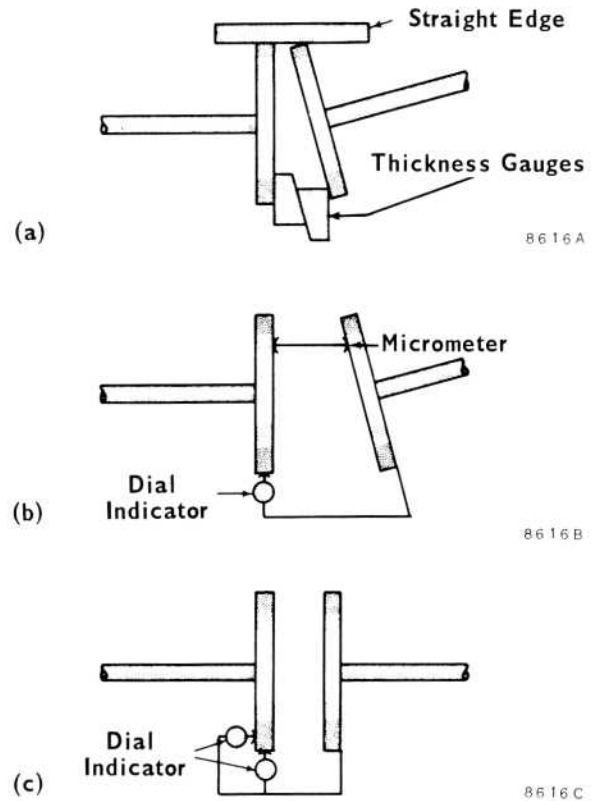

Fig. 2 — Methods Of Shaft Alignment

The plunger of one indicator shown in Fig. 2-C, is parallel to the shaft with its button resting on the coupling face at a radius equal to or greater than the coupling disc. The plunger of the other indicator is at right angles to the shaft, with its button resting on the rim of the coupling.

When positioning the indicators, Fig. 3, the plungers should be depressed about

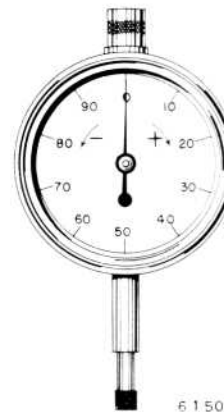

Fig. 3 — Dial Indicator

half the total travel. This will permit the indicator to show plus or minus readings when the shafts and couplings are rotated.

After the indicators are applied, the coupling halves should be rotated together and both indicators brought to the uppermost or top position. In this position the bezels or movable faces of the indicators should be turned so the indicator pointers register zero.

Two circles, Fig. 4, should be drawn on a sheet of paper with the figure "zero" written at the top of each circle. ("Zero," of course, is the reading on the dial indicator at the start of the check.)

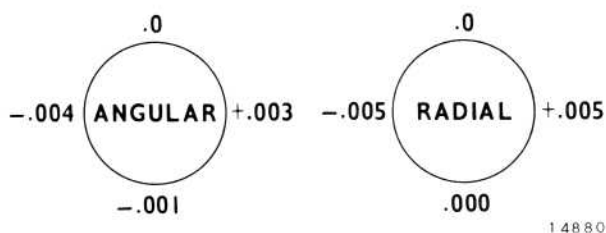

Fig. 4 — Typical Set Of Indicator Readings

One circle should be used to record the angular displacement and the other to record the radial displacement. The shafts, both driving and driven, should now be rotated together through  $90^\circ$  or one-fourth of a turn and a set of readings taken.

The reading on the indicator that is riding the face or back, as the case may be, of the driven flange will show the angular displacement in thousandths of an inch. This reading will be written either as a zero if the indicator does not show movement, or as a plus or minus value. If the pointer moves in the direction of increasing numbers, that is, 10-20-30 etc., it should be written as a plus value. If the indicator reads in the opposite direction such as 90-80-70 etc., it should be written as minus (-) 10, 20, 30 etc., respectively. We will assume it reads a + .003" for this example and therefore will record it as such.

Next the indicator riding on the rim of the driven coupling is read. The result shows the amount of radial displacement at this point and is recorded. For example, we will assume it reads + .005".

This procedure is repeated at  $90^\circ$  intervals and the reading recorded until the indicators are back to the same point they were at the start of the check, that is, the top. At this point both indicators should again read zero. If they do not read zero, the readings just taken should be disregarded and the entire setup checked for tightness and a new set of readings taken. If the indicators return to zero, it may be assumed that the obtained indicator readings are accurate. A typical set of readings is shown in Fig. 4.

These readings show a maximum indicator reading of .004" for coupling angularity, and a maximum indicator reading of .005" for radial run-out.

Generally speaking, the alignment of this coupling would be satisfactory for service; in most cases limits of .010" total indicator reading for angular misalignment, and a .010" total indicator reading for radial misalignment are allowable.

In the preceding example, if it were desired to improve the radial alignment, a look at the figures makes it evident that the shaft is satisfactory as far as the vertical plane is concerned; in other words, there is no need to raise or lower the shaft. It is apparent, however, that by moving the shaft a distance of .005" horizontally towards the side having the minus (-) .005" reading, the total indicator reading for radial alignment will be reduced to zero; this is a very desirable reading but seldom attainable in actual practice.

Corrections for angular misalignment are made by moving the driven shaft so that its centerline coincides with the centerline of the driving shaft. In the case where

the radial alignment is good and angular alignment is out of limits, it is apparent that the coupling end of the driven shaft is located properly, but that its remote end must be moved to correct angular misalignment.

Alignment correction is usually a combined operation calculated to correct both angular and radial misalignment at the same time. It is difficult to give a hard and fast rule governing the thickness in shims to be removed to make a certain correction in alignment because of the varying distances from the coupling to the point at which the shaft is supported. For the correction of radial misalignment when angular alignment is within limits, it is a fairly simple matter to move the shaft at right angles to its axis, the amount shown on the dial indicator where its reading is greatest. It is well worth a few extra minutes of study of the readings taken so that when the move to correct alignment is made it will be in the right direction.

There will be cases where no special tools or instructions are available to accomplish alignment of some particular piece of equipment. Some ingenuity on the part of the operator will take care of such situations. However, it should be remembered that the indicators must be securely mounted to read accurately and both shafts should be rotated together. Make a circle and record the indicator readings, and before making a move of the equipment be confident that the readings have been correctly evaluated.

In case a piece of equipment is being changed out, it is good practice to mount the replacement part on the original shims. This, generally speaking, will give the best possible starting point for alignment.

It is recommended that the alignment tools and dial indicator gauges listed in the

latest revision of the Service Tools Catalog, should be obtained to facilitate alignment procedures used on EMD rotating equipment.

## RUBBER COUPLING ALIGNMENT

### AIR COMPRESSOR COUPLINGS

A representative application of the rubber drive coupling is shown in Fig. 5. Two inspections are required when aligning or checking alignment of these couplings. The first inspection is a length measurement, or the distance between the coupling and the shaft. The second inspection is of the angular misalignment which can be checked by either one of two methods. The first method employs a dial indicator, while the second method requires the use of feeler gauges.

#### LENGTH MEASUREMENT

The distance between the mating faces, at the 6 o'clock or bottom vertical position, as shown in Fig. 5, must be held to  $.500'' + .020'' - .000''$ , for applications where the compressor is coupled to the engine, or  $.520 + .020'' - .000''$  for applications where the compressor is coupled to the generator. The engine should be at room temperature. If the engine crankshaft is hot, that is, if the engine has been running, the measurement will be reduced and may be as low as  $.470''$  and  $.490''$  respectively.

#### ANGULAR ALIGNMENT

##### Using Dial Indicator

Angular alignment at each flexing member can be measured by attaching a dial indicator, Fig. 5, to coupling flange and indicating against the face of the mating flange. Both indicators should be in the same plane when checking at two couplings.

Mount the indicators on brackets and set the dials at zero with the indicator at the

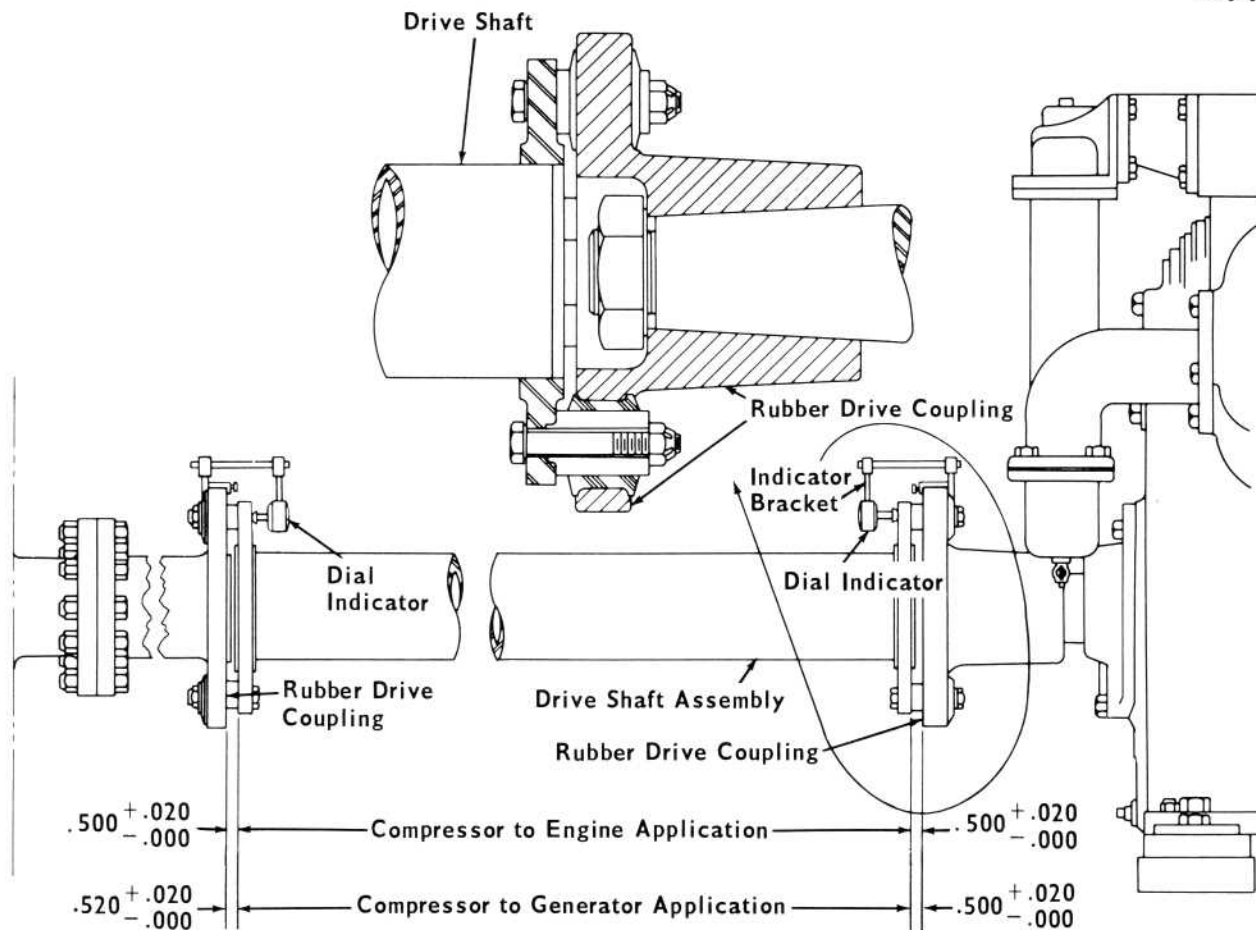

14888

Fig. 5 — Application Of Air Compressor Couplings

12 o'clock position. During rotation of the shaft, record the indicator readings every 90° of rotation. Angular misalignment must not exceed .020" total indicator reading when indicating point is on not less than a 10" diameter.

#### Using Feeler Gauges

Angular alignment at each flexible member can be inspected by measuring the distance between the mating flanges at 90° intervals (four points). Rotate the shaft 180° and again measure at 90° intervals. The readings taken (8 for each coupling) must be within .020" of each other.

#### REPLACEMENT OF AIR COMPRESSOR RUBBER BUSHING

The air compressor rubber couplings do not require any routine maintenance or

lubrication. However, it may be necessary or desirable to replace the bonded rubber bushings. The need for replacement is evidenced by accumulations of small rubber particles directly under the coupling.

To facilitate the removal and application of the rubber bonded bushing, a puller tool may be used. As shown in Fig. 6, the tool parts are used in opposite sides of the coupling depending upon removal or application of the bushings.

When installing the rubber bonded joint bushings, a small amount of rubber lubricant should be applied on the leading pressed rubber edge of the bushing. This lubricant is mixed with three to five parts or water before use, and should be stirred occasionally while in use. Other lubricants which are not detrimental to the rubber bushing may be used.

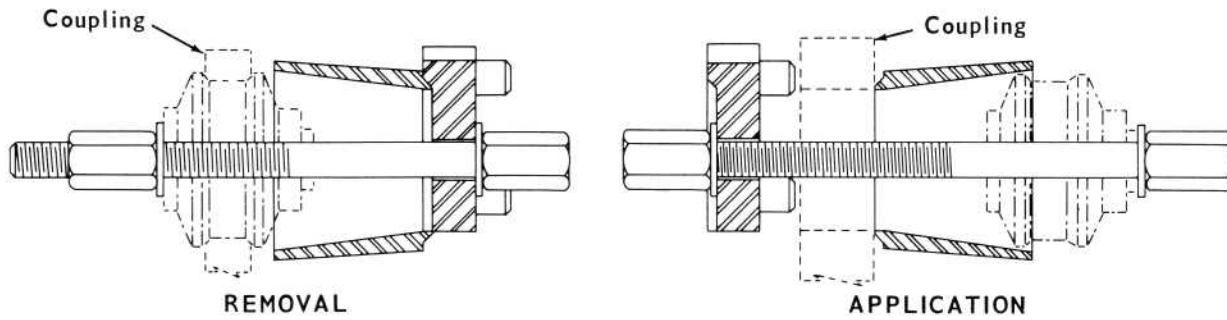

Fig. 6 — Rubber Coupling Bonded Joint Puller

14881

NOTE: After bushing application, it is recommended that at least 72 hours elapse before installing the coupling. This waiting period is required to allow the rubber lubricant to dry. When the lubricant is still wet, the bushing can easily move from its desired location.

The bonded joint bushing must be installed past its normal location to properly seat the lips of the bushing. Bonded joint bushing installing and removing tool must be reversed and the bushing centered or until a  $.470'' \pm .010''$  dimension shown in Fig. 7

is obtained to maintain the bushing faces in the same plane. If installing tool is not available, a press may be used.

A bushing application gauge, Fig. 8, is available to measure the  $.470'' \pm .010''$  dimension. This gauge consists of a tripod-legged base supporting a lever indicating arrangement at its center. To measure the  $.470'' \pm .010''$  dimension, the gauge is positioned so its large tripod legs rest on the flange of the coupling and its center actuating disc contacts the metal center sleeve of the bushing, inside the locating prongs. If the bonded joint bushing is properly located, the pointer of the gauge will be within the limiting scribe marks on the gauge scale.

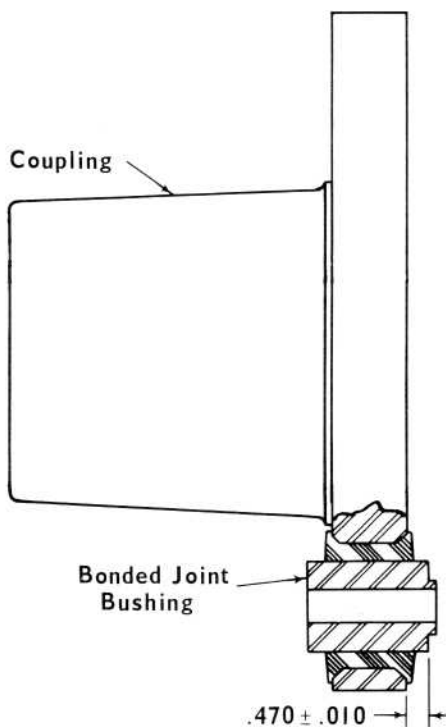

8970

Fig. 7 — Bushing To Coupling Application

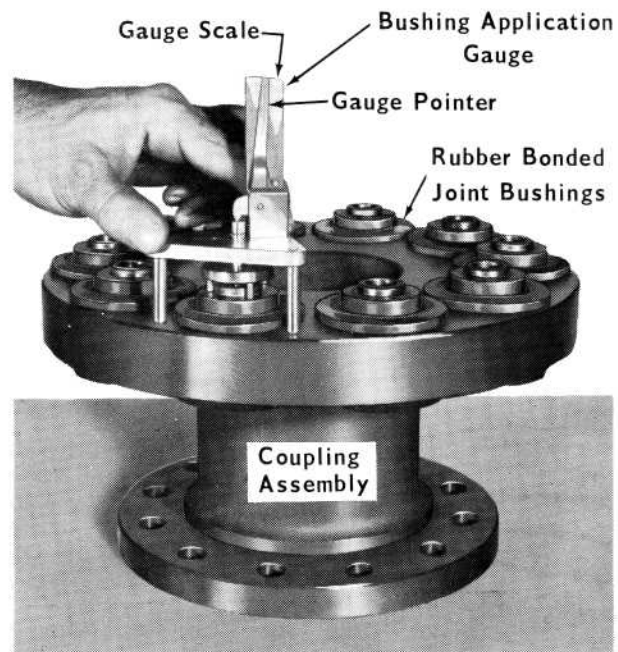

Fig. 8 — Bonded Joint Bushing Application Gauge

8971

A calibration fixture having three calibrating discs, .460", .470", and .480" is part of this gauge to provide a check on the pointer accuracy. A large disc simulates the coupling and the smaller discs are placed on the large disc. The gauge is placed on this assembly to check the pointer positioning.

## AUXILIARY GENERATOR COUPLING

The auxiliary generator must be installed so that the mounting distance between the coupling flanges on the driving and driven assemblies do not vary from the coupling assembly free length more than  $1/32"$ . The driving shaft on the engine should be pulled out from the engine to take up end play before this measurement is taken. See the Maintenance Data for the correct distance between the coupling flanges for specific model locomotives.

The flexible type couplings used in this installation will generally absorb the misalignment factor incurred in the installation making it unnecessary to use dial indicators to check the alignment. However, if it is desirable to use dial indicators they may be mounted as shown in Fig. 9. The indicators are attached to brackets secured to the respective drive flange with the indicating button contacting the inner face of the inside coupling flange. Position the indicators directly across

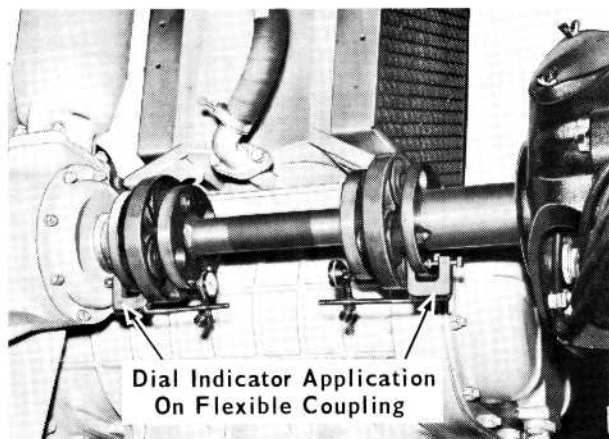

Dial Indicator Application  
On Flexible Coupling

8631

Fig. 9 — Auxiliary Generator Drive  
Coupling Alignment

from each other and set the dials to zero. Rotate the coupling by turning the engine crankshaft, taking readings at the 3 and 9 o'clock positions only. The angular deflection shown on either indicator should not exceed .020" total indicator reading.

## SPEED INCREASER COUPLING

The speed increaser drive shaft couplings are installed as shown in Fig. 10. The shaft must be located in the taper bushing to provide the correct distance between shaft flange and face of speed increaser flywheel when the taper bushing is tight. See Maintenance Data for specific model.

Angular alignment should be checked at each flexing member by attaching a dial indicator to the coupling flange and indicating against the face of the mating flange. Angular misalignment should not exceed .020" total indicator reading when revolving both shafts together.

## GENERATOR TO ENGINE ALIGNMENT

Engines and generators are correctly aligned and tested before the locomotive is delivered. The alignment should be checked or inspected at intervals specified in the Scheduled Maintenance Program. When aligning or checking alignment, the limits given for the particular generator should be followed.

To make the engine and generator revolve true and comparatively free from vibration, the alignment through the coupling must be exact. In order that the generator may perform correctly in its electrical phase of operation, the air gap between the main poles and the armature must be held to the correct dimension and be evenly distributed at all poles.

The generator armature is in effect the flywheel for the engine and is joined to the engine crankshaft by means of a flexible coupling. An engine coupling disc and a generator coupling disc comprise the

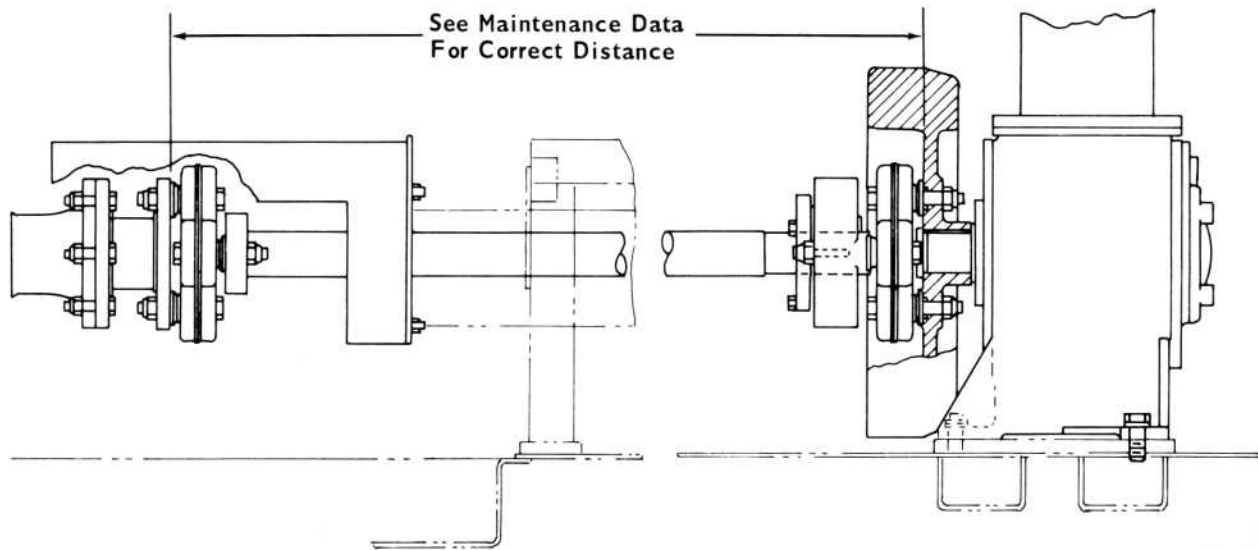

Fig. 10 — Speed Increaser Drive Coupling Alignment

14889

flexible coupling. Each disc is mounted at its center to its respective part by mounting bolts and both discs are joined at the rim or outer circumference by coupling bolts. The engine coupling disc rim has degree markings around its circumference and holes provided for an engine jack or turning bar for rotating the crankshaft.

Fundamentally all flexible couplings connecting the engine and generator are the same, however, they do differ somewhat in design.

Current couplings have a "V" channel in the engine coupling disc and a "V" serration in the generator disc. Mounting bolts, both rim and center have clearance holes at the couplings. This design provides for interchange between units not possible with earlier body bound or reamed fit mounting bolts. However, the following recommendations should be adhered to in the application of the serrated coupling.

After installation of the generator, the generator coupling disc is mated to the engine coupling disc and the rim bolts applied and properly torqued to 295 ft-lbs. The coupling is then checked as follows:

1. The gap between engine and generator coupling disc at the rim bolts should not be less than .0015". Care should be taken to tighten all coupling bolts

uniformly to avoid cocking the coupling on the serrations.

2. The recessed indicator surface and the serrations on the coupling are held concentric with the center bore. The entire rotating assembly is balanced about this same center. Thus the run-out of the indicator surface is a measure of out of balance. Concentricity is not held at the outside rim of the coupling disc, except at the fan pilot on generators equipped with fans.

## GENERATOR ALIGNMENT INFORMATION

The alignment of generator with engine is divided into three operations:

1. Thrust - Finding the longitudinal position of armature with respect to the generator frame.
2. Angular - Neutralizing the angularity of generator to engine coupling.
3. Radial - Balancing and setting the air gap between the generator armature and field poles.

Angular and radial alignment is carried out simultaneously. The following procedure can be used when aligning all single bearing type generators. However, due to minor changes each generator will also be considered separately.

1. After the generator is coupled to the engine, it is very important to locate the generator frame to have the bearing located axially to avoid a thrust load in either direction. The bearing float for each generator is given in the cross-section illustration for each generator and is also stamped on the bearing cover or the end housing depending on the type of generator.
  2. Remove one oil pan handhole cover and take out all the crankshaft thrust by prying against a crankshaft web and crankcase. Move all crankshaft thrust toward the generator end of engine.
  3. Locate a measurement number "x" stamped with 1/2" numbers on the end housing. This measurement is determined during final generator assembly with the armature or rotor (depending on the type of generator) positioned so its end play is taken up in the direction of the engine coupling.
  4. Move the generator frame in either direction away from or toward the engine to obtain a measurement which will be  $1/16" + 3/64" - 1/64"$  greater than the measure "x" stamped on the generator.
- NOTE: This measurement will be  $1/8" + 0" - 1/32"$  for AR10 generators.
5. The radial and angular alignment can be accomplished by using two dial indicators mounted on a support rod which is screwed into a 1/4" hole in the coupling adapter. Both indicators revolve with the coupling adapter. In most cases the plunger of one indicator rides on the back of the coupling disc and the plunger of the other indicator on the outside vertical face of the stator housing. (Except the AR10 generator which must have the second indicator mounted so the plunger rides on the O.D. of the D-14 alternator.)
  6. With the engine turning jack assembly, the flywheel should be turned so that the indicator rod is in a vertical position. This will place both indicators near the top of the generator.
  7. After clamping the indicators on the rod, the indicator buttons are brought to bear upon the surfaces on which they will ride. To set the indicators, depress the plungers about half of the total travel. This will permit the indicator to show plus or minus readings as the coupling is rotated.
  8. With the indicator set, turn the flywheel, with the engine turning jack,  $180^\circ$  in a clockwise direction, when facing the bearing end of the generator. Then rotate the flywheel  $270^\circ$  in a counterclockwise direction. The counterclockwise rotation instead of continued clockwise rotation is necessary to prevent the indicators from striking the alternator terminal board, if so equipped. As the indicators revolve around the generator, readings should be taken at each  $90^\circ$  increment. When the indicators return to the original starting point they should register zero. If they do not register zero, reset and make another check or replace indicators if defective.
  9. If the indicator readings are within the limits given for each generator, the generator is considered aligned and the mounting and coupling bolts can be tightened to the specified torque.
  10. Since any movement of the generator frame affects both the coupling and air gap, readings for both must be taken after each setting. Experience will indicate the proper shim thickness to bring the readings within the specified limits. Full length shims should be used when possible, although spot shims may be necessary to conform to the limits.

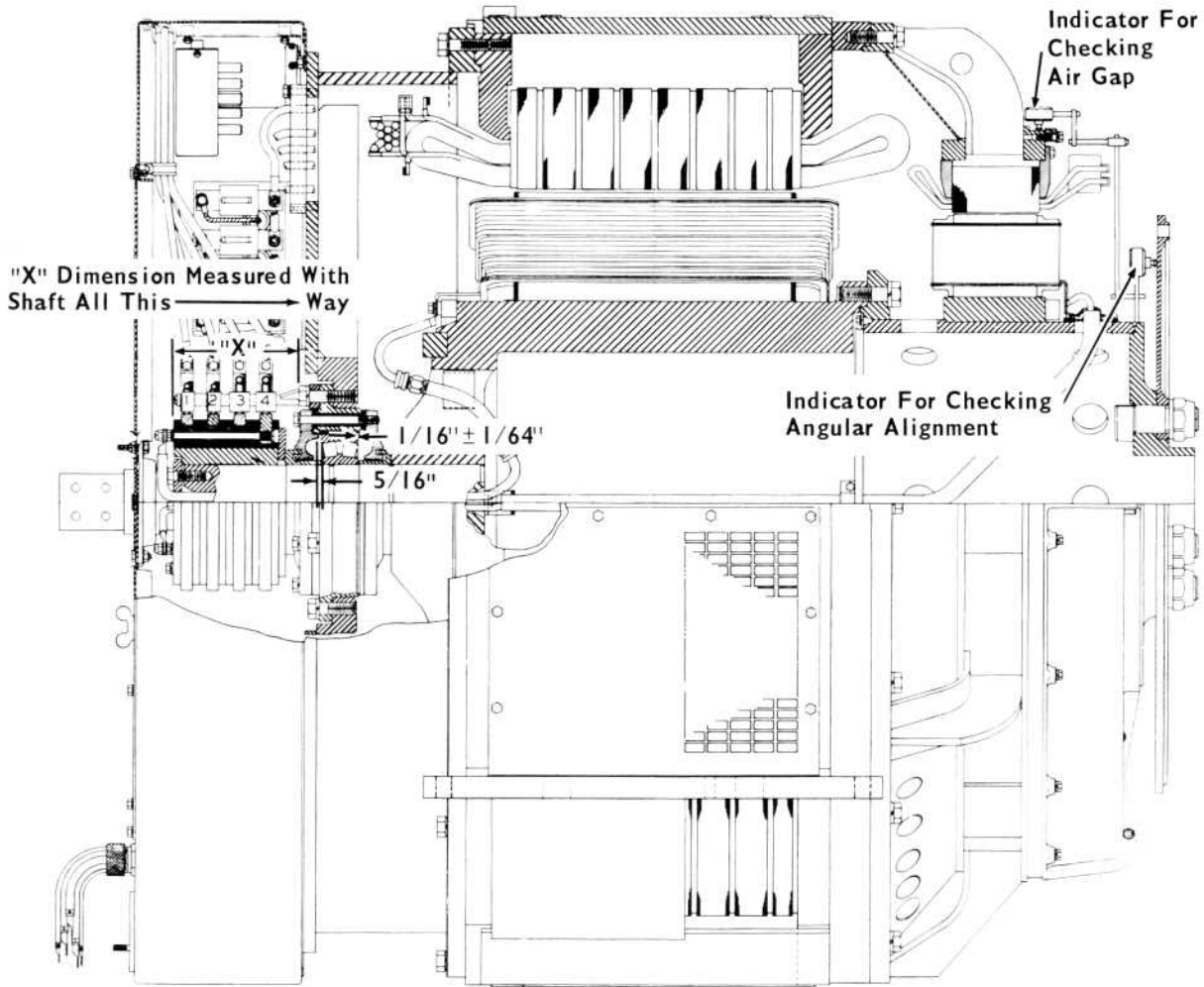

AR10 - D14

14890

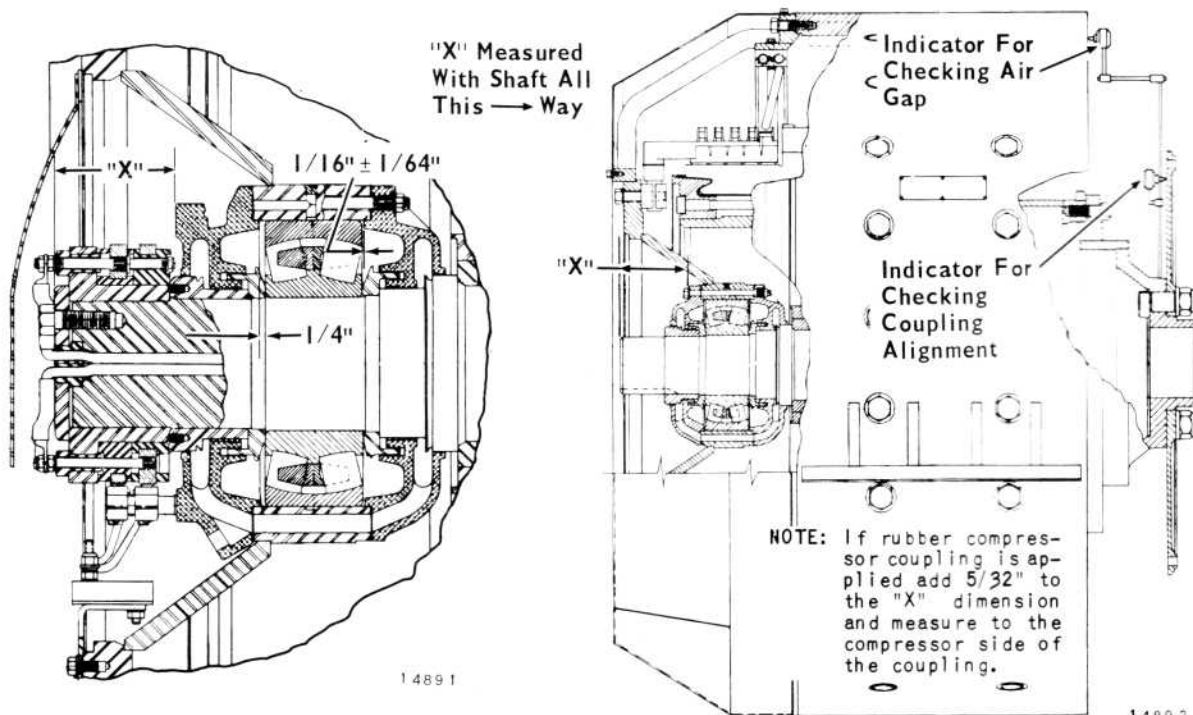

D32 - D14

D32S And D32T

14892

Fig. 11 — Alignment Cross-section

## AR10-D14, D32-D14, D32S, D32T GENERATOR

After the generator is mounted in place and connected to the engine, move the generator frame away from or toward the engine in order to obtain a measurement which is  $1/16'' + 0'' - 1/64''$  ( $1/8'' + 0'' - 1/32''$  on AR10-D14) greater than dimension "x" shown in Fig. 11. This dimension is stamped on the end housing of each generator. Also stamped on the end housing and shown in Fig. 11 is the total end movement of the bearing in the bearing housing.

Now that the longitudinal positioning of the generator has been accomplished, the angular and radial alignment can be checked. Use two dial indicators mounted on a rod which is screwed into a tapped hole in the coupling adapter, Fig. 11. Both indicators will revolve with the armature shaft. The plunger of one indicator will ride on the back of the generator coupling disc and the plunger of the other indicator will be positioned as shown in Fig. 11 for the specific model generator. Any generators equipped with a guard over the rotor must have the guard removed before applying the dial indicator rods. A special indicator with an offset pickup arm will be required to permit rotation on turbocharged engines.

Rotate the crankshaft so that the coupling adapter is turned to a point where the dial indicator rod is in a vertical position pointing upward. Set the dial indicators to zero and rotate the crankshaft so that the generator rotor turns in a clockwise direction (facing the bearing end of the generator), taking readings at  $90^\circ$  and  $180^\circ$ . Then turn the rotor  $270^\circ$  in a counterclockwise direction and again take dial indicator readings. If the figures recorded on the dial indicators are within the limits given in Fig. 12, the generator is satisfactorily aligned and may be tightened down.

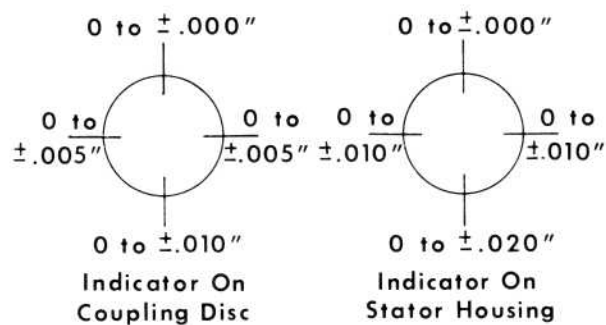

14893

Fig. 12 — Dial Indicator Alignment  
Tolerances

## D32 GENERATOR WITH FAN

After the generator is mounted in place and connected to the engine, move the generator frame away from or toward the engine in order to obtain a measurement which is  $1/16'' + 0'' - 1/64''$  greater than dimension "x" shown in Fig. 13. This dimension is stamped on the end housing of each generator. Also stamped on the end housing and shown in Fig. 13 is the total end movement of the bearing in the bearing housing.

The radial and angular alignment can be checked by using two dial indicators mounted on a rod which is screwed into a tapped hole in the coupling adapter, Fig. 13. Both indicators will revolve with the armature shaft. The plunger of one indicator will ride on the radial inside surface of the generator fan and the plunger of the other indicator will ride on the outside diameter of the frame adapter ring.

Rotate the crankshaft so that the coupling adapter is turned to a point where the dial indicator rod is in a vertical position pointing upward. Set the dial indicators to zero and rotate the crankshaft so that the generator rotor turns in a clockwise direction (facing the bearing end of the generator), taking readings at  $90^\circ$  and  $180^\circ$ . Then turn the rotor  $270^\circ$  in a counterclockwise direction and again take

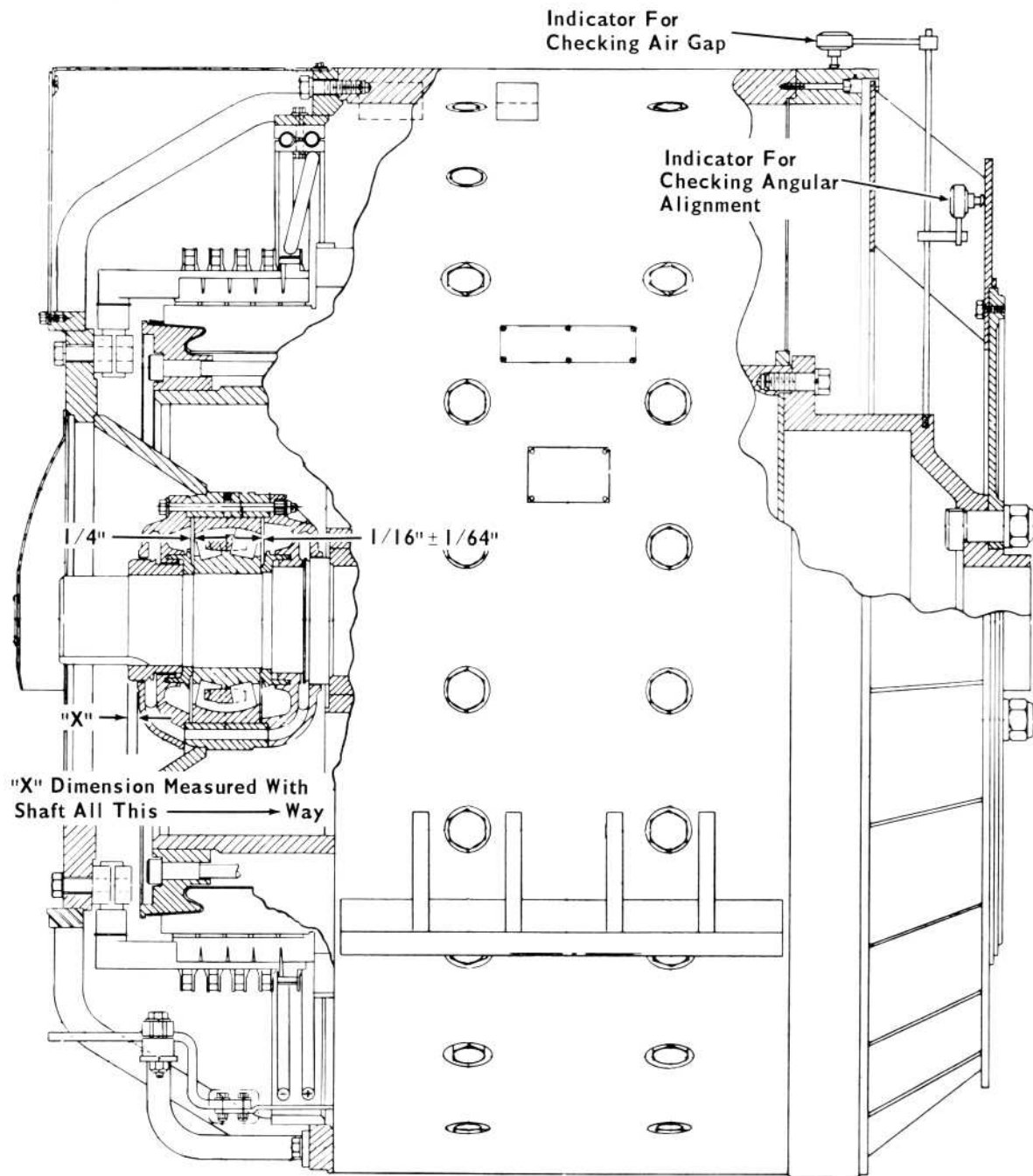

Fig. 13 — D32P Alignment Cross-section

14894

dial indicator readings. If the figures recorded on the dial indicators are within the limits given in Fig. 14, the generator is satisfactorily aligned and may be tightened down.

### D25 GENERATOR WITHOUT FAN

During the original assembly of the generator, the armature is purposely posi-

tioned so its end movement is all taken up in the direction toward the coupling disc. The total end movement of the bearing is shown in Fig. 15. The shaft retainer at the commutator end is then stamped with chisel marks at four quarter locations around the retainer. A measurement "x" is then taken from the chisel marks or the bearing cover face to the outside end face of the shaft retainer, Fig. 15. This

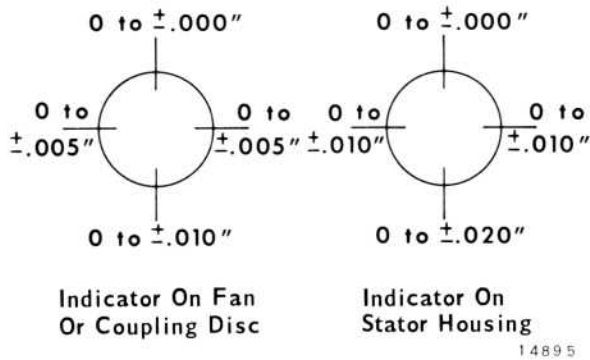

Fig. 14 — Alignment Tolerances For D32 Generator With Fan

measurement, is stamped on the end bell beneath one of the commutator covers.

When the generator is mounted in place and connected to the engine, move the commutator away from or toward the engine until a measurement of  $1/16'' + 0'' - 1/64''$  between the chisel marks and the bearing cap face is obtained. This will give a total exposed length on the retainer of  $1/16''$  more than the "x" dimension.

The angular and radial alignment can be adjusted by using two dial indicators

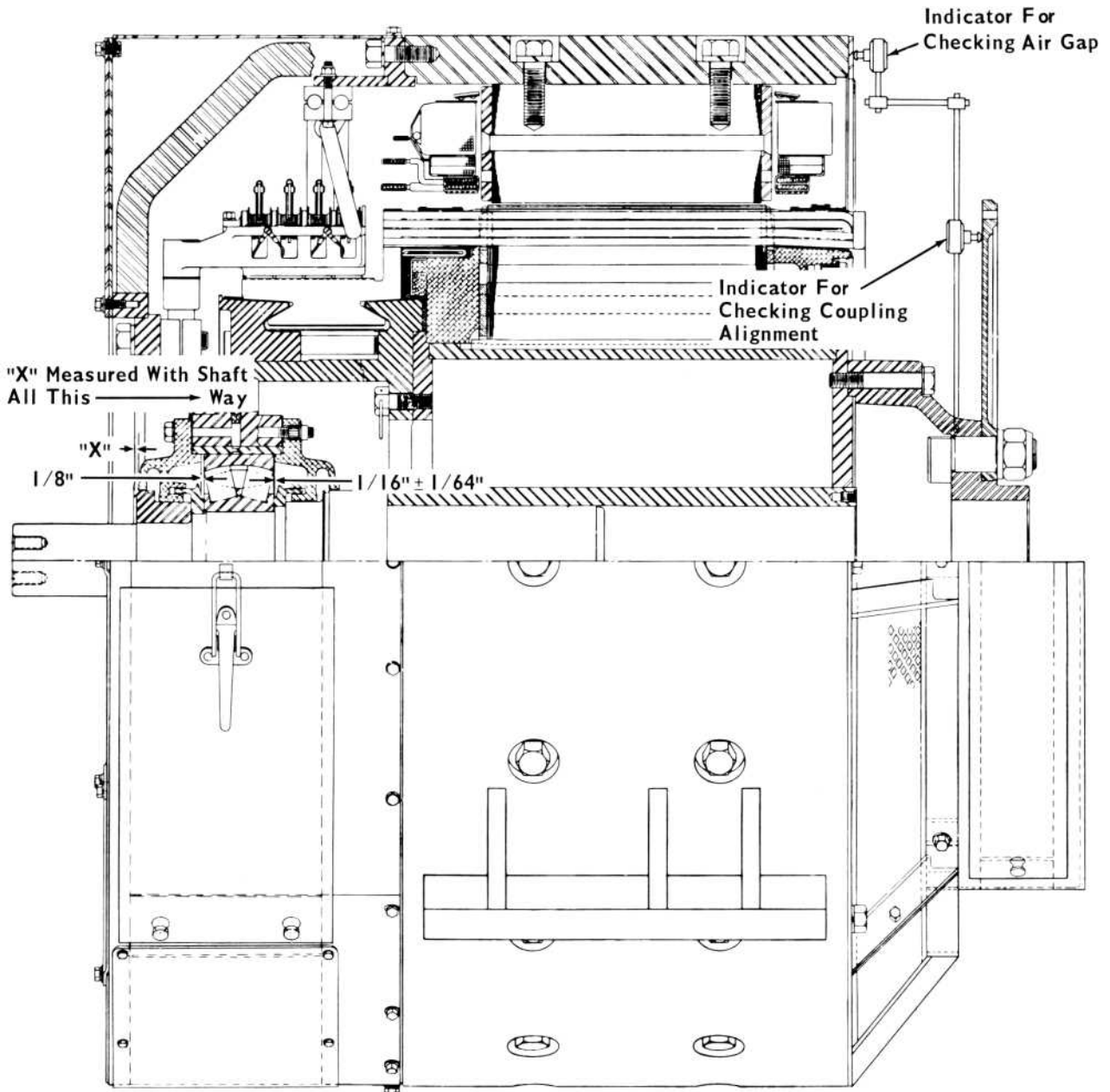

Fig. 15 — D25P Alignment Cross-section

mounted on a rod which is screwed into a tapped hole in the coupling adapter, Fig. 15. Both indicators will revolve with the armature shaft. The plunger of one indicator will ride on the back of the generator coupling disc and the plunger of the other indicator will ride on the vertical face of the stator housing. The protective guard assembly must first be removed before applying the dial indicator rods.

Rotate the crankshaft so that the coupling adapter is turned to a point where the dial indicator rod is in a vertical position pointing upward. Set the dial indicators to zero and rotate the crankshaft so the generator rotor turns in a clockwise direction (facing the bearing end of the generator), taking readings at  $90^\circ$  and  $180^\circ$ . Then turn the rotor  $270^\circ$  in a counterclockwise direction and again take dial indicator readings. If the figures

recorded on the dial indicators are within the limits given in Fig. 14, the generator is satisfactorily aligned and may be tightened down. When the dial indicator is returned to its original starting position the gauge must read zero or the alignment must be rechecked.

## D25 GENERATOR WITH FAN

During the original assembly of the generator, the armature is purposely positioned so its end movement is all taken up in the direction toward the coupling disc. The total end movement of the bearing is shown in Fig. 16. The shaft retainer at the commutator end is then stamped with chisel marks at four quarter locations around the retainer. A measurement "x" is then taken from the chisel marks or the bearing cover face to the outside end face of the shaft retainer, Fig. 16. This

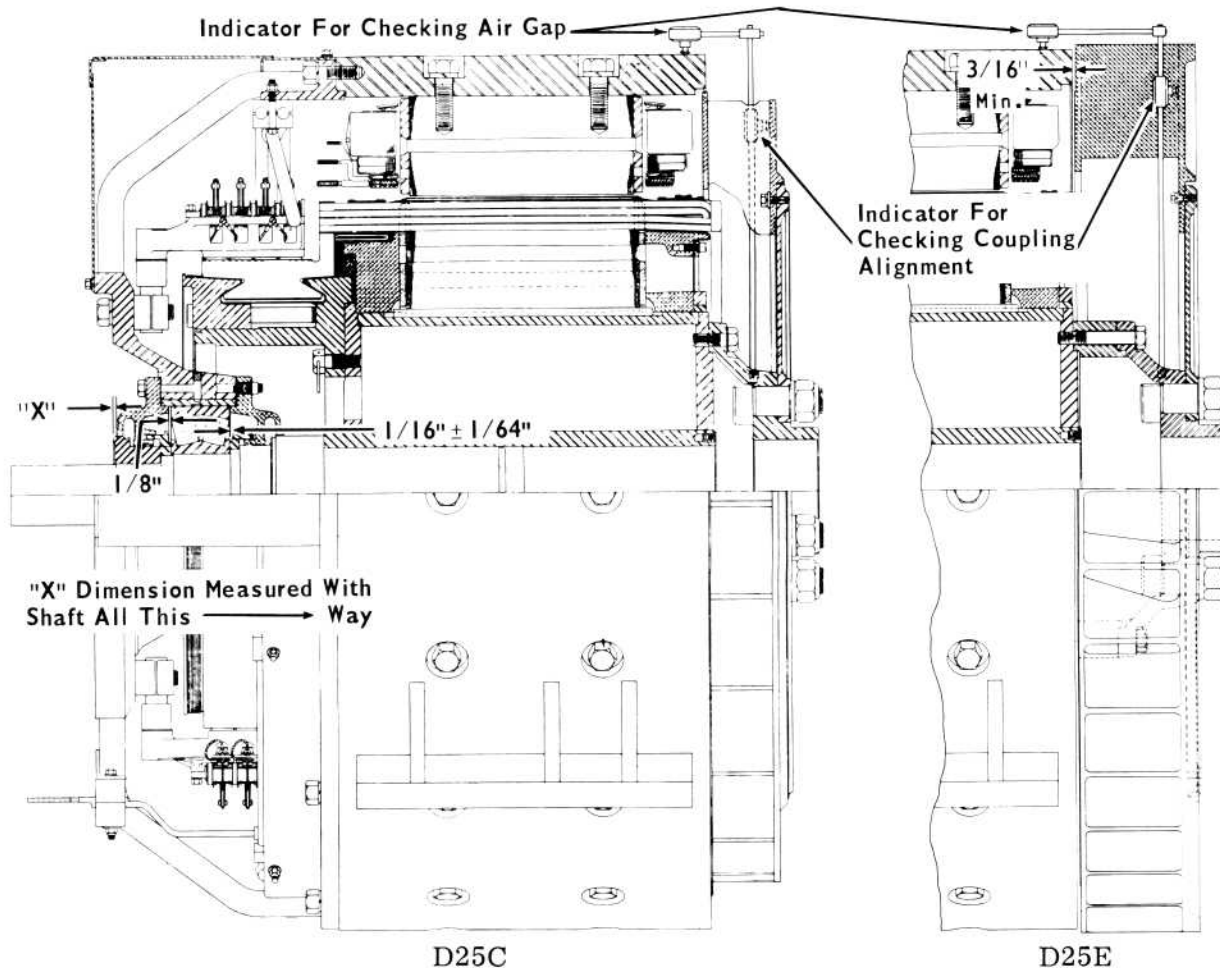

Fig. 16 — D25 Alignment Cross-section

14897

measurement is stamped on the end bell beneath one of the commutator covers.

When the generator is mounted in place and connected to the engine, move the commutator away from or toward the engine until a measurement of  $1/16'' + 0'' - 1/64''$  between the chisel marks and the bearing cap face is obtained. This will give a total exposed length on the retainer of  $1/16''$  more than the "x" dimension.

The angular and radial alignment can be adjusted by using two dial indicators mounted on a rod which is screwed into a tapped hole in the coupling adapter, Fig. 16. Both indicators will revolve with the armature shaft. The plunger of one indicator will ride on the radial inside surface of the generator fan and the plunger of the other indicator will ride on the outside diameter of the stator frame. A closed type fan will have a hole provided to insert the dial indicator, as shown in Fig. 16. An open type fan, Fig. 16, should also have the clearance checked between the fan and stator frame. If an air duct or blower housing is provided it must be removed from the generator before the dial indicators can be applied.

Rotate the crankshaft so that the coupling adapter is turned to point where the dial indicator rod is in a vertical position pointing upward. Set the dial indicator to zero and rotate the crankshaft so that the generator rotor turns in a clockwise direction (facing the bearing end of the generator), taking readings at  $90^\circ$  and  $180^\circ$ . Then turn the rotor  $270^\circ$  in a counterclockwise direction and again take dial indicator readings. If the figures recorded on the dial indicators are within the limits given in Fig. 17, the generator is satisfactorily aligned and may be tightened down. When the dial indicator is returned to its original starting position the gauge must read zero or the alignment must be rechecked.

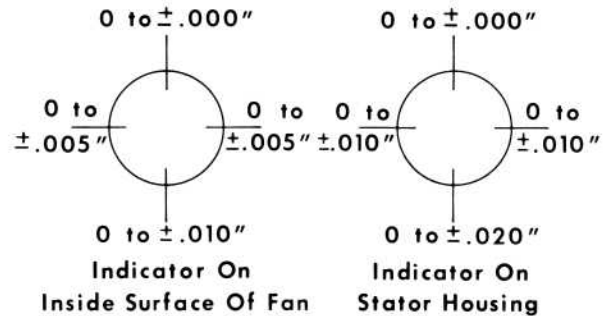

Fig. 17 — D25 Alignment Tolerances

1.4898

## MAINTENANCE DATA

### AUXILIARY GENERATOR COUPLING FLANGE DISTANCE

GP40, SD40, SD40M, SDP40 .....	22-1/8" + 1/16" - 0"
GP38, SD38, SD38M, SDP38 .....	16-5/16" + 1/16" - 0"
SD45, SDP45, FP45 .....	23-13/16" + 1/16" - 0"
SW1500 .....	14-3/4" + 1/16" - 0"
SW1000 and Export Locomotives with D25 generator .....	10-3/4" + 1/16" - 0"
SW1000 with D32 generator .....	26-1/2" ± 1/32"
Non-turbocharged Export locomotives with D32 generator .....	13-3/4" + 1/16" - 0"

## SPEED INCREASER

Distance Between Shaft Flange And Speed Increaser Flange or Flywheel

G22 .....	6' 8-25/32"
G26 .....	7' 5- 5/16"

## EQUIPMENT LIST

Bushing installing and removing tool .....	8239562
Rubber lubricant .....	8251651
Bushing application gauge .....	8254465
Dial indicator .....	8255423