



SERVICE DEPARTMENT

ELECTRO-MOTIVE DIVISION • GENERAL MOTORS CORPORATION

MAINTENANCE INSTRUCTION *plbho*

FLEXICOIL TRUCK ASSEMBLIES (ELECTRIC DRIVE)

DESCRIPTION

The truck assembly, Figs. 1 and 2, is one of the major parts of the locomotive. Two truck assemblies support the entire weight of the locomotive and provide a means for the transmission of tractive effort to the rails. They are designed to withstand the stresses resulting from road shock due to normal variations in the roadbed and other conditions encountered during operation. An important function of the truck assembly is to absorb and isolate these shocks so that they will not be transmitted to the locomotive underframe and the equipment mounted on the underframe.

The diesel locomotive tractive horsepower is supplied to the traction motors mounted in the truck. The traction motors are geared to the driving axles to supply the power to the driving wheels which, in turn, apply this force at the points where they contact the rail. The traction force, in turn, is transmitted through the axle journal boxes to the truck frame, and through truck frame pressure areas to mating pressure areas in the truck bolster. The bolster then transmits the force through its center bearing to the center bearing of the mating carbody bolster to move the locomotive and supply the locomotive drawbar horsepower. The drawbar horsepower is the horsepower available for moving the train.

The speed control of the locomotive is applied through the truck assembly. The forward and reverse accelerating speed control is accomplished through the traction motors and their geared connection to the driving axle. Decelerating locomotive speed control may be obtained through reduction in power applied to the traction motors, or through the dynamic brake function of the traction motors when they are electrically arranged to absorb the momentum of the locomotive or train when they are driven as generators. In addition to the dynamic brake, locomotive speed is controlled by the application of

friction type brake shoes against the truck wheels.

Brake cylinders, brake levers and links, sand boxes and connected sand traps (if used), sand delivery valves and piping, and the traction motor suspension arrangement are also components of the truck assembly.

The basic function of all trucks is the same, however, truck construction varies depending on the truck application. Direct electric driven trucks are classified as two axle-two motor trucks (B-B designation); three axle-three motor trucks (C-C designation); and three axle-two motor trucks (A1A designation). The three axle-two motor truck has an idler axle and non-driving wheels to support part of the weight of the locomotive. Two sizes of traction motors are used on the truck assemblies, the large standard broad gauge motor, and the smaller universal gauge motor. The standard broad gauge motor can be used on all gauges of 4' 8-1/2" and wider. The universal gauge motor can be used on meter gauges up through the widest gauge.

The locomotive carbody is free to move relative to the trucks both laterally and vertically within limits. Stabilizers are used to damp the vertical spring action between the bolster and truck frame, and safety straps or holders tie the truck to the carbody but permit freedom of movement of the truck within the set limits for curve negotiation.

SIX WHEEL - THREE MOTOR TRUCK

A typical six wheel-three motor truck equipped with standard gauge traction motors is shown in Fig. 1. Trucks are manufactured with several different side frame and wheel spacing widths to suit the particular track gauge on which the truck is to be used.

The "H" design bolster (1) is supported at each of the ends by two springs (18) held in spring

*This bulletin is revised and supersedes previous issues of this number.

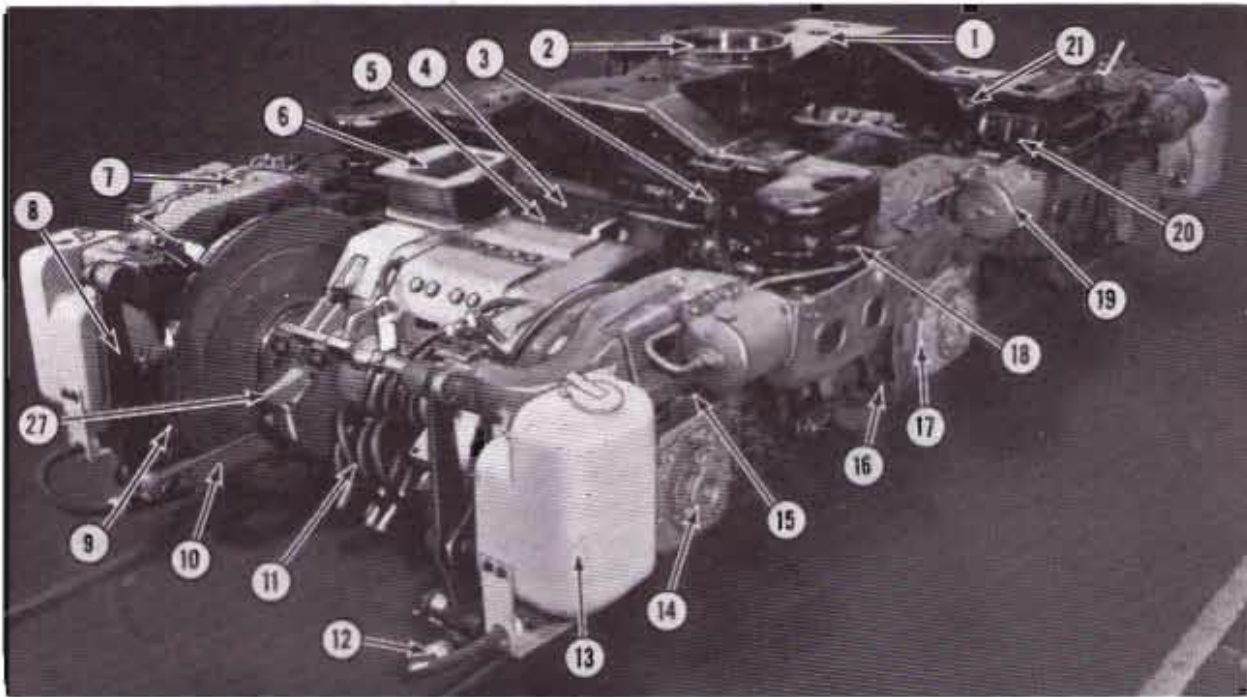

18897

Top View

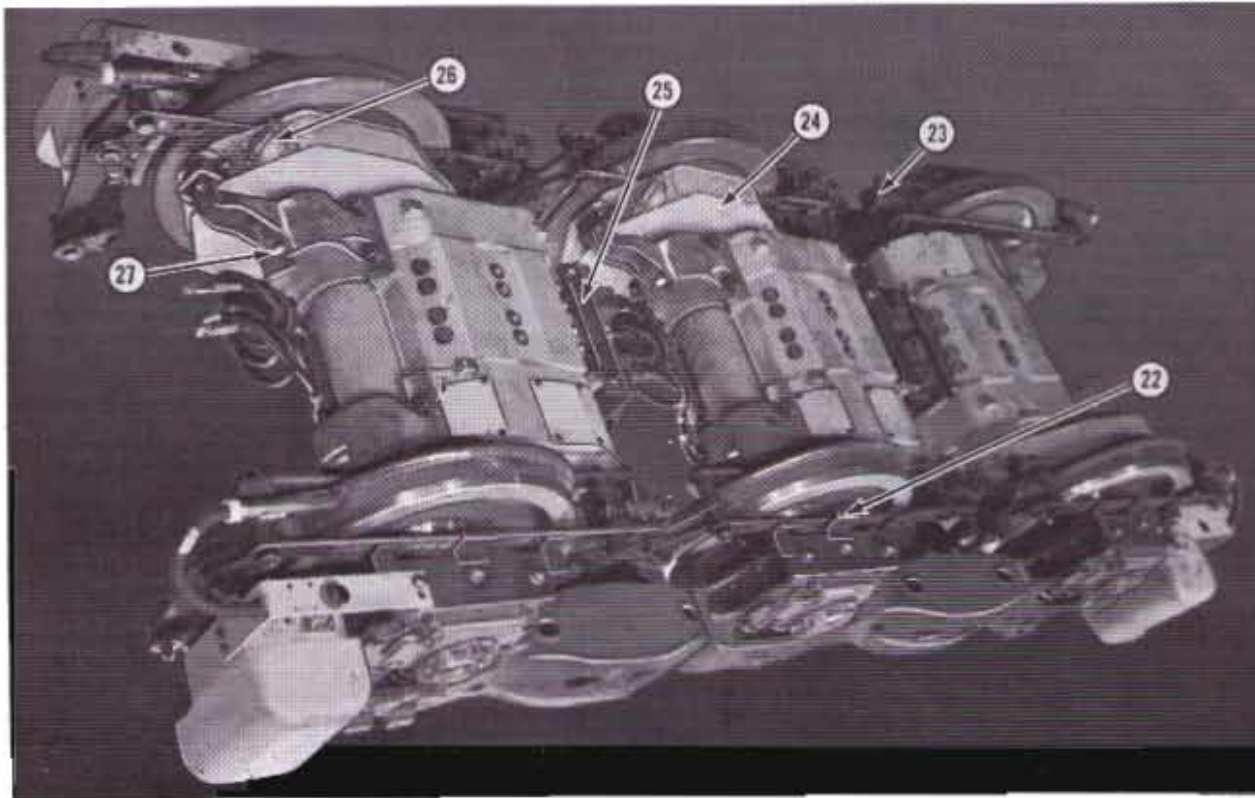

11306

Bottom View

- | | | |
|--|----------------------------------|--|
| 1. "H" Design Bolster | 10. Brake Lever Connecting Strap | 20. Truck Frame Bolster Pedestal |
| 2. Bolster Center Bearing | 11. Traction Motor Cable | 21. Bolster Stop |
| 3. Safety Link | 12. Sand Application Hose | 22. Brake Connector Strap Guide |
| 4. Truck Frame Transom | 13. Sand Box | 23. Brake Slack Adjuster |
| 5. Traction Motor Nose Suspension Location | 14. Journal Box | 24. Gear Case |
| 6. Traction Motor Air Duct | 15. Journal Box To Frame Springs | 25. Traction Motor Suspension Pin Keeper |
| 7. Main Truck Frame | 16. Main Frame Pedestal | 26. Gear Case Inspection Opening |
| 8. Brake Rigging Lever | 17. Journal Box Pedestal Flange | 27. Traction Motor Support Bearing Box |
| 9. Friction Brake Shoe | 18. Bolster Support Springs | |
| | 19. Brake Cylinder | |

Fig. 1 - Typical Flexicoil Electric Drive Six Wheel-Three Motor Truck

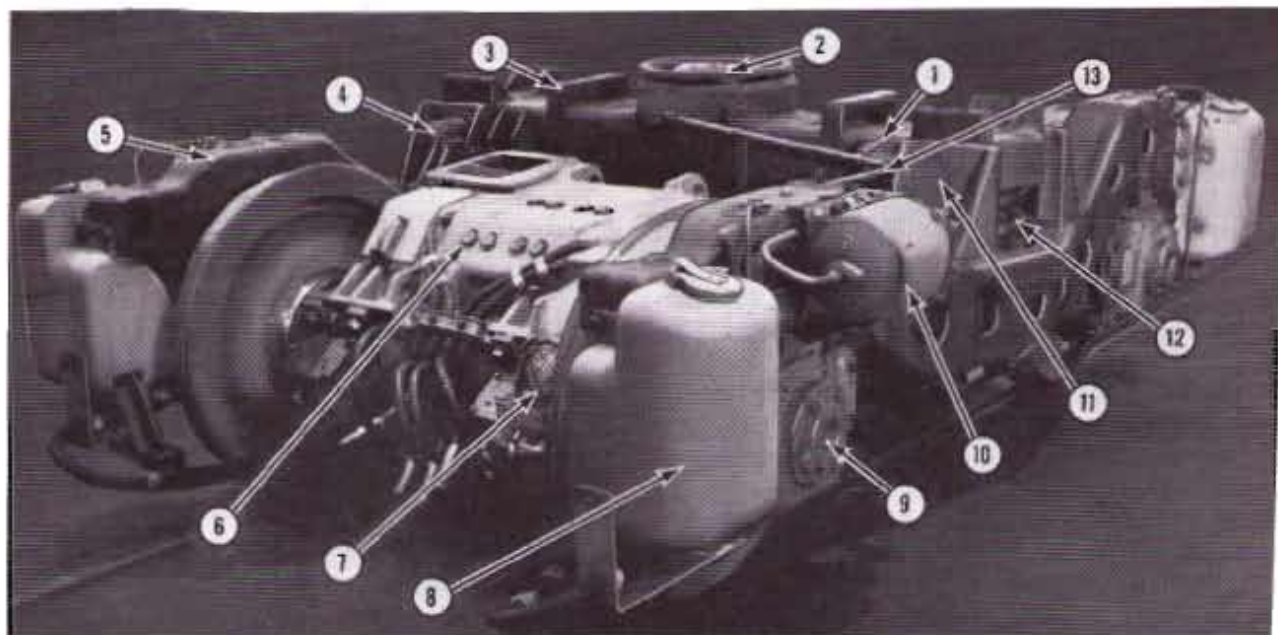

Top View

11307

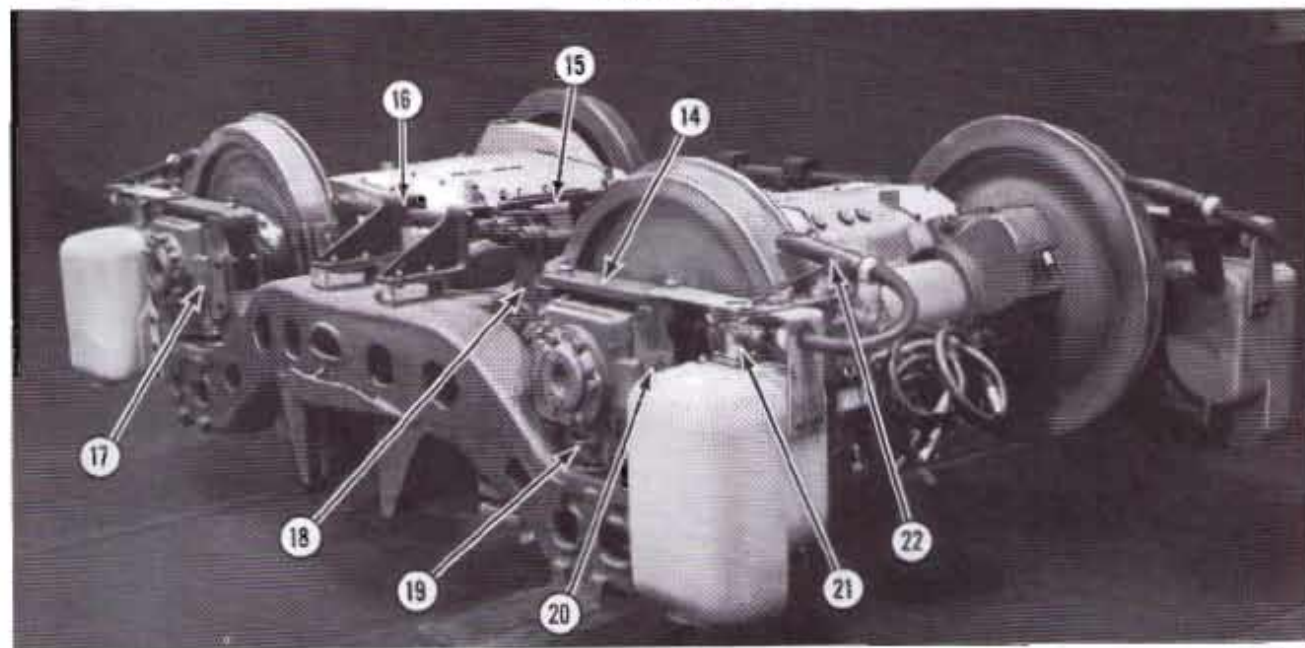

Bottom View

11308

- | | | |
|---|-------------------------------------|--|
| 1. Bridge Design Bolster | 8. Sand Box | 15. Traction Motor Suspension Pin Keeper |
| 2. Truck Center Bearing With Protective Ring Guard | 9. Journal Box | 16. Brake Rigging Guide |
| 3. Side Bearing | 10. Brake Cylinder | 17. Journal Box Pedestal Flange |
| 4. Piston Friction Device Housing | 11. Truck Frame Bolster Pedestal | 18. Brake Lever |
| 5. Main Truck Frame | 12. Bolster Spring | 19. Journal Box Springs |
| 6. Traction Motor | 13. Safety Support Pin | 20. Truck Pedestal |
| 7. Gear Case Inspection Opening | 14. Pedestal Tie Bar | 21. Sand Trap |
| | | 22. Sand Application Nozzle |

Fig. 2 - Typical Electric Drive Four Wheel-Two Motor Truck

pockets in the main truck frame (7). Two of the four ends of the "H" are held between upright pedestals (20) which are an integral part of the truck frame. Through this arrangement, motive force of the truck is transmitted to the bolster. Bolster stops (21) limit the side movement of the

bolster. Spring-loaded friction pistons at the pedestal ends of the bolster damp vertical spring movement. The bolster center bearing (2) receives the locomotive carbody center bearing. Two links (3), one of which is shown, connect the bolster to the main frame, but permit vertical movement

of the bolster. The safety link also prevents separation of the bolster from the truck assembly.

The main truck frame (7) is supported on springs above each axle journal box (14). Two double coil spring assemblies (15) are used at each journal box between the journal box and the truck frame. Each journal box is held between two pedestals (16) which are an integral part of the truck frame. The pedestals are joined at the bottom by a pedestal tie bar which is bolted to the bottom of each pedestal. Journal box pedestal flanges (17) limit the lateral or side movement of the journal box. The coil springs at the journal boxes and the springs between the main truck frame and the bolster absorb vibration and road shock during locomotive operation.

Pistons in brake cylinders (19) are connected to brake levers to actuate the brake rigging. Either clasp brakes or single shoe brakes are available.

Each traction motor is supported on its own drive axle and at a rubber nose suspension arrangement (not shown), which is located on one of the transverse truck frame transoms (4). Clean cooling air is supplied to the traction motor through the air duct (6). A flexible bellows assembly attached to the bottom of the carbody contacts, but is free to move on the air inlet flange on the traction motor when the carbody is supported by the truck. In some cases, the flexible bellows are mounted on the traction motors and are free to move on the carbody.

A sand box (13) is mounted at each corner of the truck frame. Sand traps are installed at the bottom of each sand box. Air lines are connected to each sand trap and a sand application hose (12) extends from each trap to its respective wheel.

FOUR WHEEL - TWO MOTOR TRUCK

The truck shown in Fig. 2 is a typical four wheel-two motor truck equipped with standard gauge motors, however, universal gauge motors may be used. The truck frame and wheel spacing can be obtained in different widths to suit the particular track gauge on which the truck is to be used.

This truck has a bridge design bolster (1) held at each end between upright pedestals (11) on the truck frame and supported on a double coil

spring assembly (12) at each end of the bolster. Motive force is transmitted to the bolster through the pedestal arrangement (11). A spring-loaded friction device (4), having a phenolic piston is contained in one bolster pedestal at each side of the truck. The piston presses against the bolster plate to damp action of the bolster support spring. Safety support pins (13) in each end of the bolster contact a stop on the truck frame to prevent separation of the bolster from the frame, but do not interfere with normal bolster movement.

The main truck frame (5) is supported on two coil spring assemblies at each journal box. Each journal box is held between two pedestals (20) extending below the truck frame. Each pedestal has a replaceable wear plate or liner. Pedestal flanges (17) on the journal box limit the journal box lateral movement. The ends of the pedestals are joined by a tie bar (14) bolted to the end of each pedestal, which transfers part of one pedestal load to the other pedestal. The truck frame sides and the two transoms are cast as a unit to provide ample strength and rigidity.

The two electric traction motors are supported on their respective drive axles and by a rubber spring suspension arrangement mounted on each frame transom. A flexible bellows mounted on each traction motor or on the carbody conducts cooling air into the motor from a mating opening in the carbody or traction motor.

One brake cylinder (10) is mounted on each side of the truck frame and is connected, by means of linkage, to the brakes at the two wheels on one side of the truck.

A sand box (8) is mounted at each corner of the truck frame. Sand traps are installed at the bottom of each sand box. Air lines are connected to each sand trap and sand discharge lines extend from each trap to its respective wheel.

MAINTENANCE

NOTE: Clearance and dimensional limits used in this instruction are defined as follows:

1. New limits are those to which new parts are manufactured (drawing tolerances).
2. Rebuild limits are dimensions which should be followed at the time of rebuild, to ensure satisfactory service until the time of the next scheduled overhaul.

3. Condemning limits are dimensions beyond which satisfactory operation cannot be ensured. Parts having clearance and/or dimensional measurements beyond these limits should not be used.

TRUCK CLEANING UNDER LOCOMOTIVE

The trucks should be cleaned periodically while under the locomotive to eliminate any accumulation of oil and road dirt. An oily accumulation presents a fire hazard and tends to increase the wear of moving parts on the truck, as well as detract from the general appearance of the trucks.

A wetting agent and an alkaline solution type cleaner can be used on the truck. Spray the wetting agent over the surfaces of the truck and let it remain for 10-15 minutes. Then using steam and an alkaline solution in a mixing gun, spray the truck assembly thoroughly. The assembly may be rinsed using hot water if desired, however, rinsing is not generally required.

When cleaning the trucks under the locomotive, the engine should be running to supply air under pressure to the traction motors. Air discharge from the motors will help to prevent any liquid spray from entering the motor. The spray, also, should be directed during cleaning so that it will not enter any openings in the motors.

TANK CLEANING OF INDIVIDUAL TRUCKS

When the truck assembly is removed from the locomotive, the traction motors, wheels, axles, and journal boxes should be removed and the remaining parts of the truck cleaned in a cleaning tank containing an alkaline solution. After a sufficient time to ensure removal of all foreign material, remove the remaining parts and rinse them with hot water.

TRUCK REMOVAL

The locomotive may be raised as shown in Fig. 3, using an overhead crane, to permit truck removal.



Fig. 3 - Locomotive Being Lifted From Trucks

11309

A drop pit arrangement, or jacks and blocks may also be used to raise and support the locomotive when removing the trucks.

Before attempting truck removal, the safety interlocks or side bearing clips, Figs. 4 and 5, must be released. They are attached to the underside of the carbody underframe and lock into recesses in the truck bolster. They can be either a bolted or pinned swing hook arrangement. Make certain that all other physical connections between the truck and the carbody, such as air brake lines, sanding air lines, traction motor cables, hand brake chain, and speed recorder drive are also disconnected.

Even though only one truck is to be removed from a locomotive, it is necessary to raise the locomotive at the opposite truck bolster until the carbody center bearing clears the bolster bearing,



Fig. 4 - Safety Interlock Assembly
Three Axle Trucks

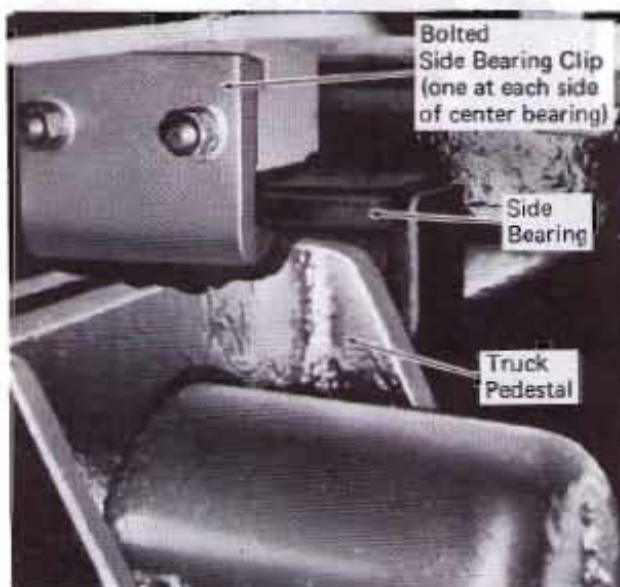

Fig. 5 - Side Bearing Clip Assembly
Two Axle Trucks

so as to prevent injury to the bearing. The end at which the truck is being removed may then be raised as necessary to allow removal of the truck.

When jacks are used to raise the locomotive, care must be taken that the jacks on both sides of the locomotive are raised equal amounts. This will ensure that each jack takes its share of the load, otherwise, the carbody might be sprung out of shape. The locomotive should be supported on blocking if it is to be held in a raised position.

Various facility drawings covering items used in removing and handling of trucks are available. A list of File Drawing numbers is contained in Service Data.

TRUCK DISASSEMBLY

The following general disassembly procedure can be followed for all the electric drive trucks covered in this instruction.

1. Before attempting to remove the bolster, disconnect the two safety links or two safety support pins which normally hold the bolster to the main truck assembly.
2. The piston of the piston friction device should also be secured to prevent the piston being forced out when the bolster is raised clear of the piston. There are two piston friction devices on each truck.
3. Using a suitable hoist and sling, lift the bolster from the truck.
4. Remove bolster springs.
5. Remove the traction motor gear case bolts and clips. The halves of the gear case then can be removed.
6. Remove the traction motor support bearing caps and axle guard, and the outer bearings.
7. Apply lifting chains to the bails on the traction motor at the nose suspension side and connect to a hoist.
8. Remove the traction motor suspension pin keeper bar to allow the keeper pins to drop down.
9. Using the hoist, lift the motor so as to compress the rubber nose pack of the traction motor nose suspension assembly. Holding the

suspension assembly compressed, insert temporary blocks about 1/2" thick under the bolt heads. (The suspension assembly can be compressed by jacking under the motor frame, as an alternate method.)

10. Lower the motor sufficiently to free the traction motor suspension assembly, and remove the assembly by sliding it out of its place between the truck frame lugs.
11. Using the hoist, lift the motor and allow it to rotate on the axle until the lower lip of the support bearing will clear the axle. The motor assembly is then free to be lifted clear of the axle.

CAUTION: Use care in lifting the motor so that the support bearings will not fall and be damaged. It is recommended that a pinion protector be applied to prevent damage to the pinion after the motor is removed.

12. It is recommended that the truck frame be inverted for the remainder of the disassembly. The frame, however, may be lifted from the wheel and axle assemblies in a normal position after disconnecting the brake linkage and removing the pedestal tie bars. When the truck frame is inverted, the wheels, axles and journal boxes can be removed as assemblies.

13. The remaining smaller parts of the truck are removed as desired.

INSPECTION AND RECONDITIONING

Bolster and Truck Frame Chafing Plates

The chafing plates on the truck frame and bolster wear due to the relative movement between these surfaces during the transfer of motive force to the bolster. If the clearances exceed the rebuild or condemning limits shown in Fig. 6, either the bolster or truck frame plates or both, should be replaced by new plates to bring the clearance

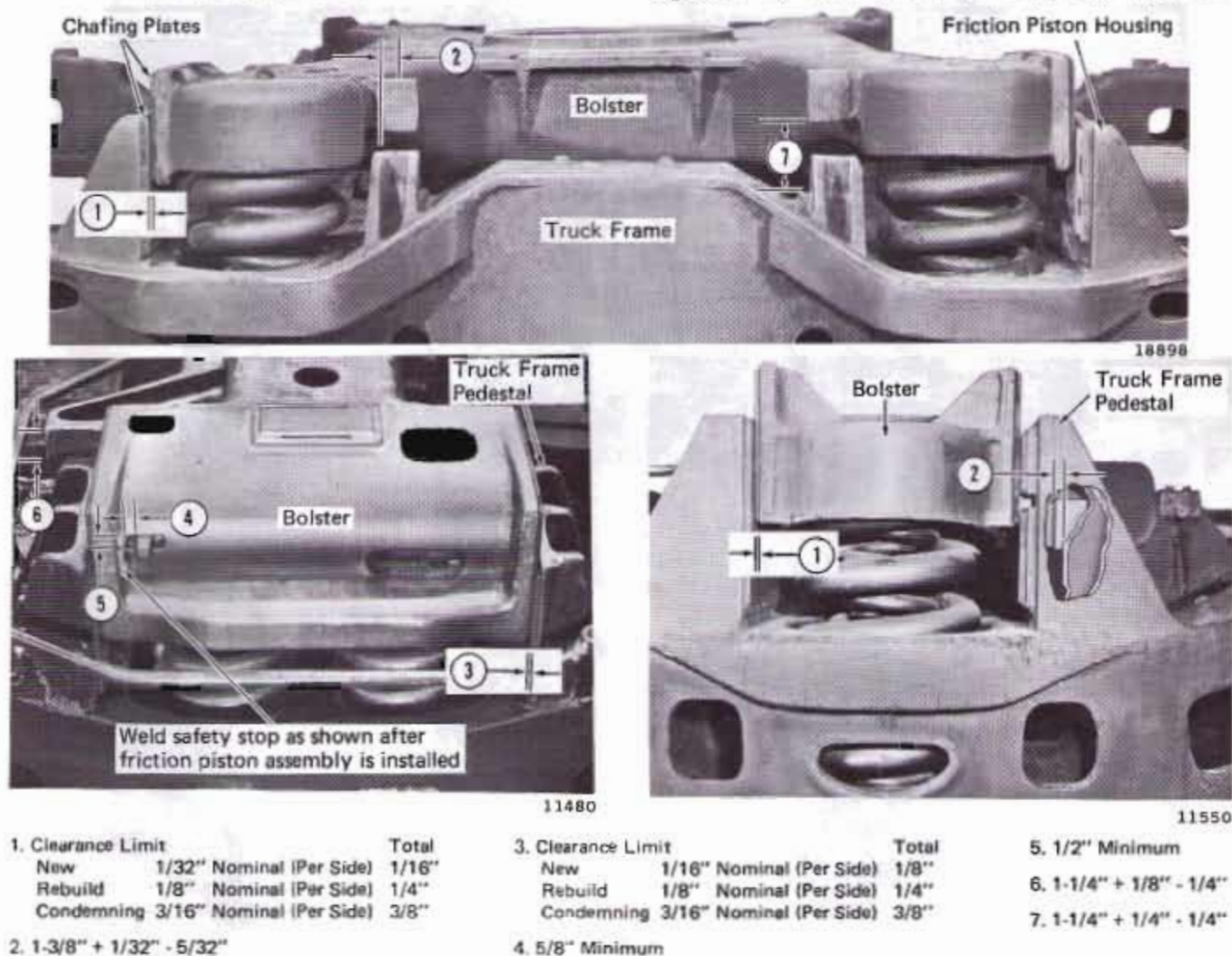

Fig. 6 - Bolster And Truck Frame Chafing Plate Clearance Limits

within the limits shown. The chafing plates and the welds which hold them to the bolster should also be inspected using a magnetic particle method of inspection. Generally residual magnetism of these truck parts is sufficient to provide an indication when the inspection particles are applied to their surfaces. The chafing plates can be removed by grinding or chipping off the fillet welds that secure the plates. If one chafing plate is removed it is recommended that the similar chafing plate in the same place on the other side of the truck also be removed as these plate surfaces should be parallel within 1/32". The replacement chafing plate should conform to the specifications of the original plate. Part

numbers of the replacement plates are given in the Parts Catalog.

Prior to weld application of the new plates, be sure that the mating surfaces of the parts to be welded are clean, smooth, and flat. The chafing plates should be welded using American Welding Society E-6016 electrodes, or equivalent. During welding, the parts should be held in the correct position and in full contact with each other. Care should also be taken that the fillet welds are not higher than the wearing surface of the plates.

Typical applications of bolster and truck frame chafing plates are shown in Figs. 7, 8, and 9.

NOTE: Apply Chafing plates to both bolster and frame. Plate surfaces to be in same plane within 1/32".

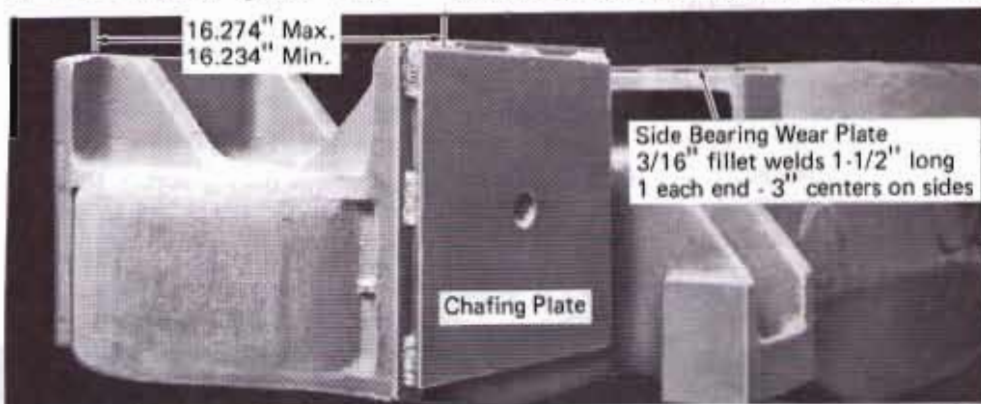

18899

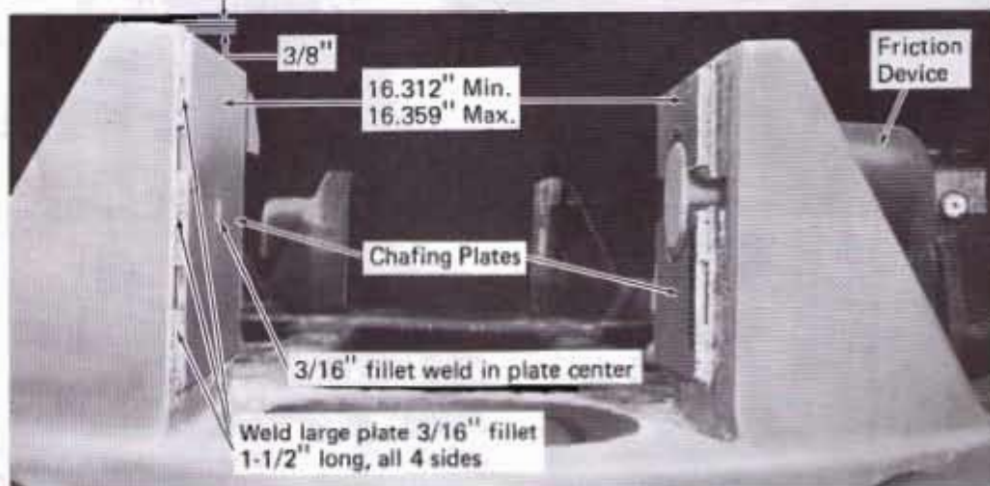

18900

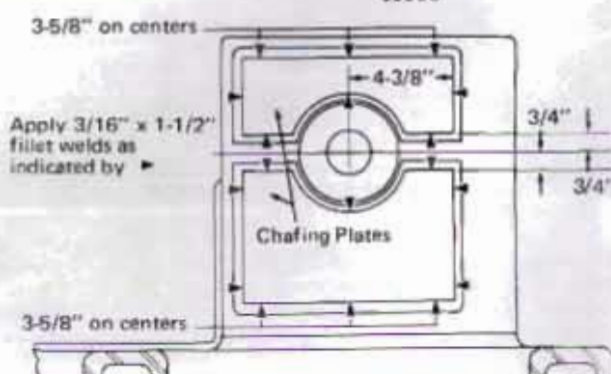
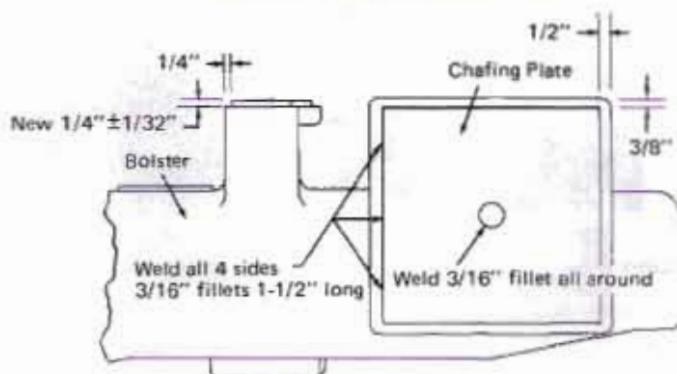

18901

Fig. 7 - Typical Chafing Plate Application To Bolster And Truck Frame - Four-Wheel Two-Motor Truck

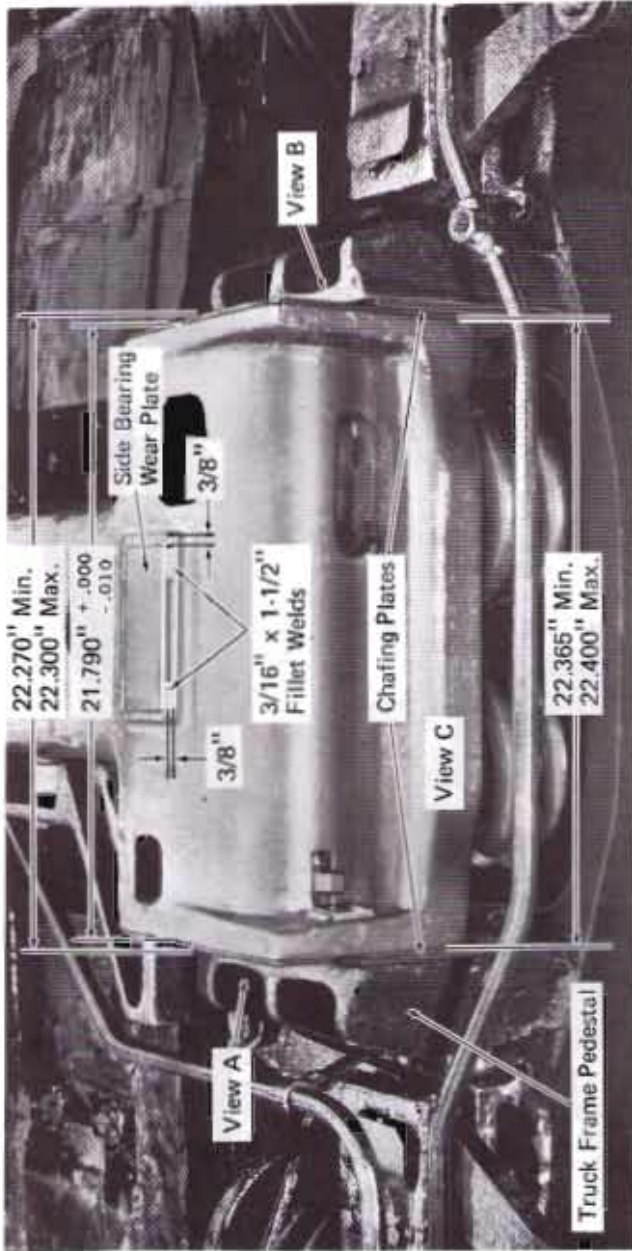

NOTE: Apply chafing plates to both ends of bolster and frame. Plate surfaces to be in same plane within 1/32"

18902

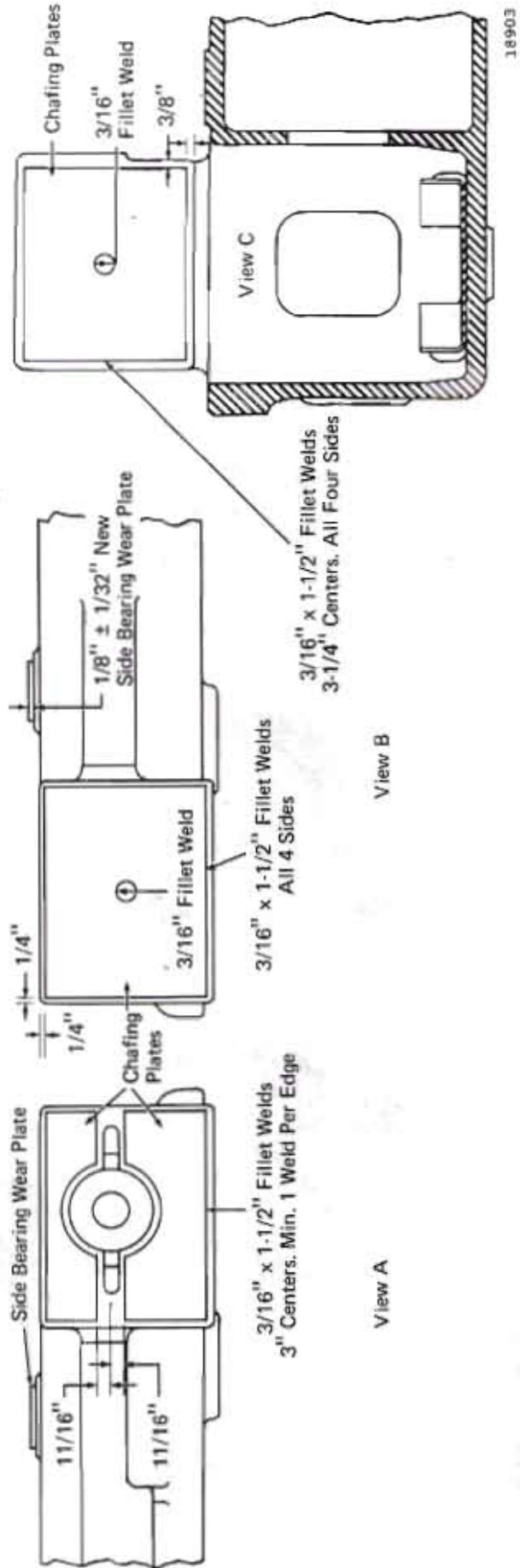
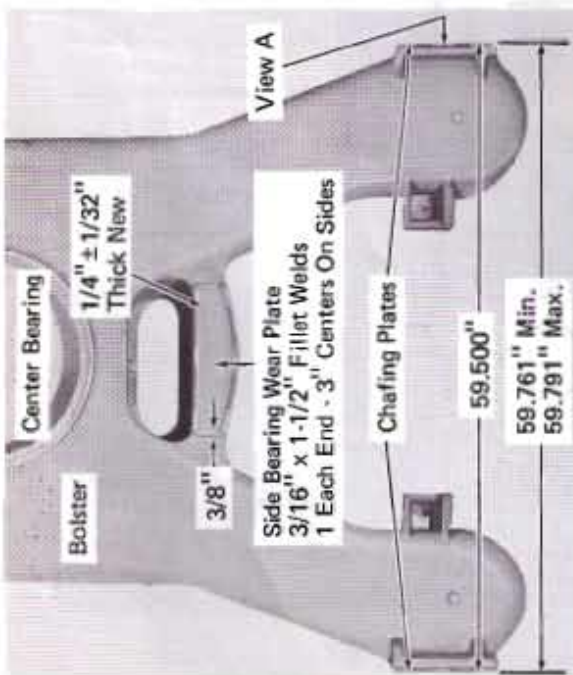
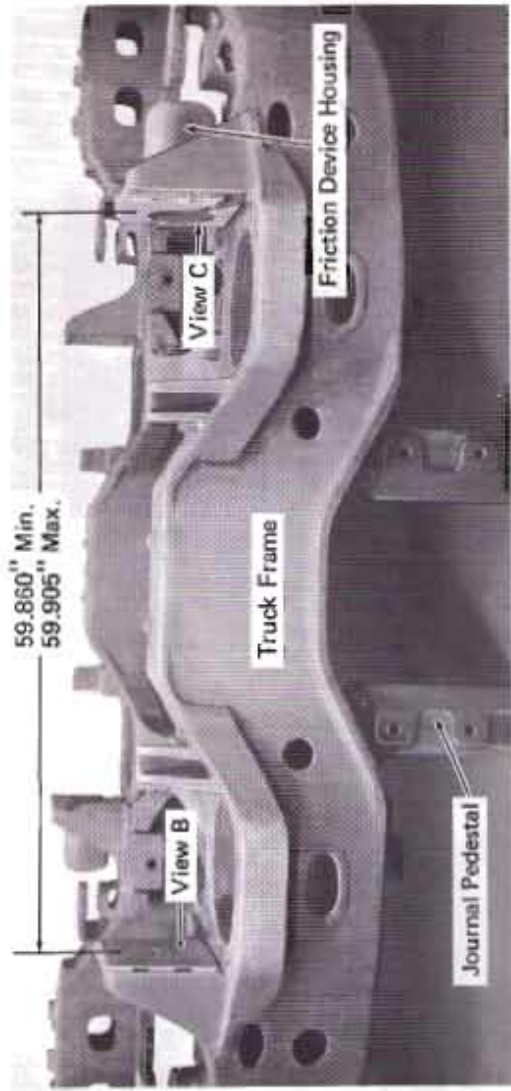

Fig. 8 - Typical Chafing Plate Application To Bolster And Truck Frame - Six-Wheel Three-Motor Trucks



18904



11570

NOTE: Surface of chafing plates should be in same vertical plane within 1/32

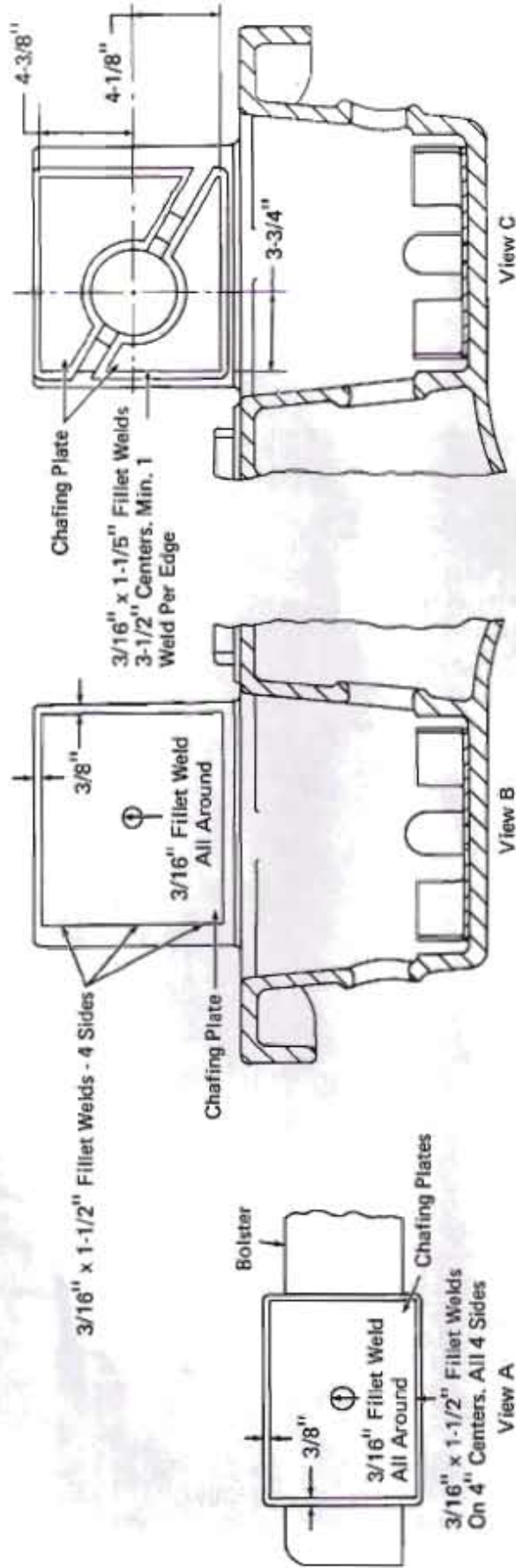

18905

Fig. 9 - Typical Chafing Plate Application To Bolster And Truck Frame - Six-Wheel Two-Motor Truck

SIDE BEARING WEAR SURFACES

The side bearing surfaces on the bolster coincide with similar side bearings on the carbody as indicated in Fig. 10. There is clearance at the side bearings in normal operation except when the locomotive leans while moving on a curved track. Side bearing contact under this condition prevents excessive tilting or leaning of the locomotive. Side bearings are not designed to carry a continuous load.

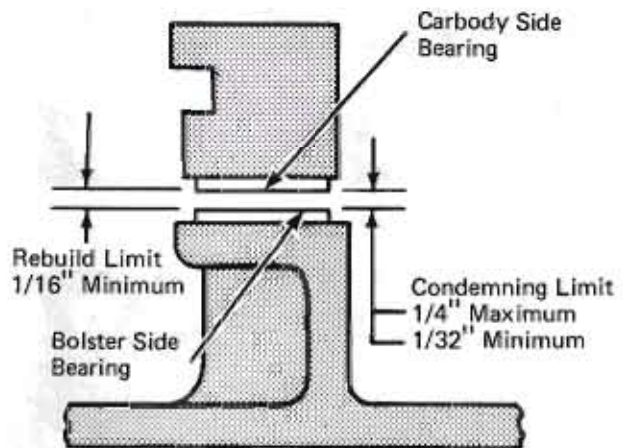

11301

Fig. 10 -- Side Bearing Wear Surfaces

Side bearing clearance on a new locomotive is $3/32''$ minimum to $1/4''$ maximum. The minimum side bearing clearance for rebuild is $1/16''$ and the condemning limit is $1/32''$. When the side bearing clearance approaches the minimum, the bolster center bearing wear plate should be replaced. The side bearing clearance should be checked before removing the truck and used to determine the rework to be done.

Application of side bearing wear plates is shown in Figs. 7, 8, or 9. It should be noted that the wear plate material used for the original side bearing plates is a mild steel. Also the thickness of the side bearing wear plate shown in Fig. 8 is $1/8'' \pm 1/32''$ as compared to a thickness of $1/4'' \pm 1/32''$ on the wear plates in figs. 7 and 9. The replacement side bearing wear plate should conform to the dimensions of the original plate being replaced.

Bolster Spring Friction Device

The bolster spring friction device is shown in Fig. 11, as it is used in the bolster assemblies. It consists of a phenolic piston, $3/8''$ thick steel

washer, and a spring contained within a cylindrical housing. The purpose of the friction device is to damp the spring action of the bolster spring to prevent harmonic spring action or excessive spring bounce. It does this by the pressing action of the phenolic piston on the surface of the bolster or truck frame chafing plate.

WARNING: When removing the bolster, the spring-loaded friction piston should be blocked to avoid possible injury when the spring is released suddenly. One method of blocking the piston is shown in Fig. 11. Also, as shown in Fig. 11, a safety stop is welded to the six wheel-three motor truck pedestal to prevent the cross pin from going through the slot in the pedestal. Application of this stop is shown in Fig. 6.

A special fixture and a jack, Fig. 11, are used to apply or remove the friction piston on six wheel-three motor trucks. Construction of this fixture is outlined in File Drawing 650, which may be obtained on request. The friction piston is applied or removed using a jack between the bolster pedestal in four wheel-two motor trucks, Fig. 11. After the piston is installed, blocking should be applied to hold the piston until the bolster has been installed.

The length of the friction piston is $3-3/8''$ new. After continued use, wear on the friction piston will gradually reduce the length and lessen the affect of the spring on the piston. As shown in Fig. 11, the minimum allowable piston length (dimension "Y") is $2-7/8''$. The total maximum wear is $1/2''$.

The piston can be continued in use until the $2-7/8''$ piston length is reached. However, when the piston reaches a dimension "Y" of $3-1/8''$, or $1/4''$ wear, a $1/4''$ thick compensating washer should be added to the standard $3/8''$ thick washer.

The piston cross pin also will be worn by movement in the guide slot. When the cross pin is worn to $3/8''$, or half the diameter, it should be removed and a new pin applied to the piston. The cross pin can be removed as outlined in the

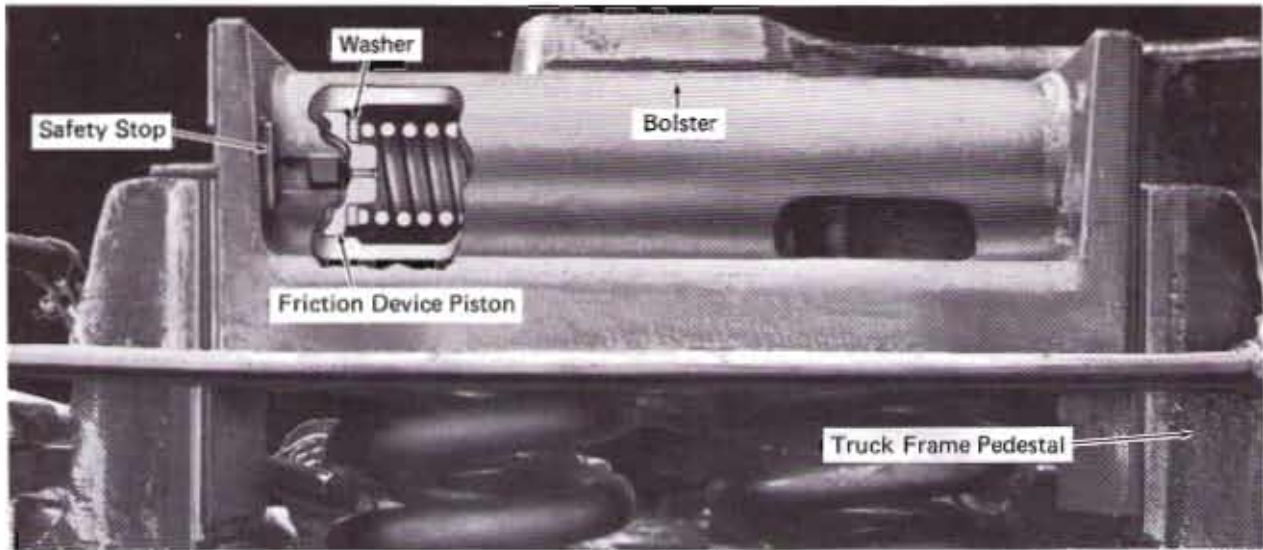

11481

Friction Device Truck – Six Wheel-Three Motor Truck Assembly

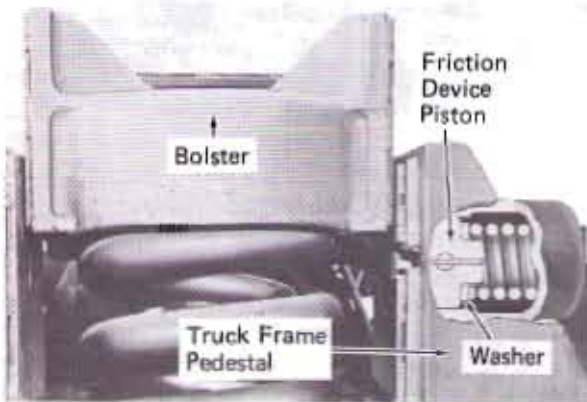

11555

Friction Device – Four Wheel-Two Motor Truck Assembly

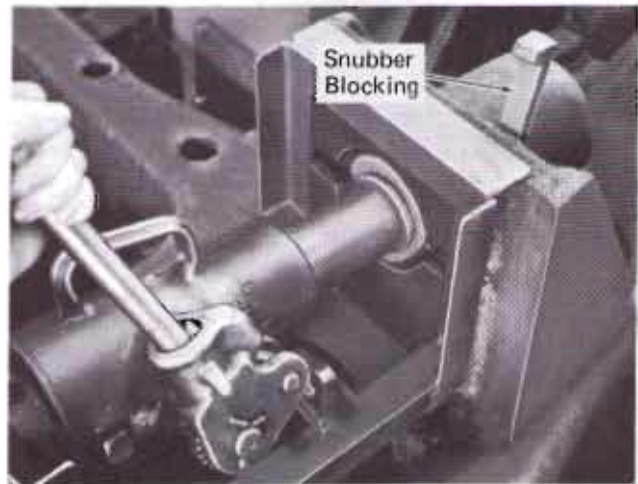

16908

Piston Jack Application – Six Wheel Truck

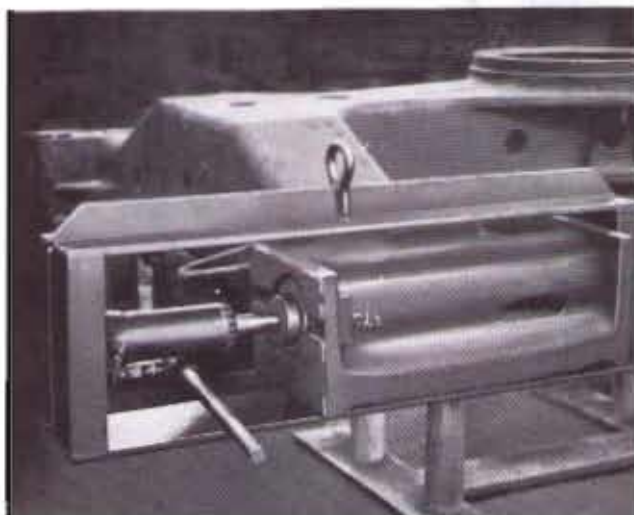

11606

Applying Piston To Bolster – Six Wheel Truck

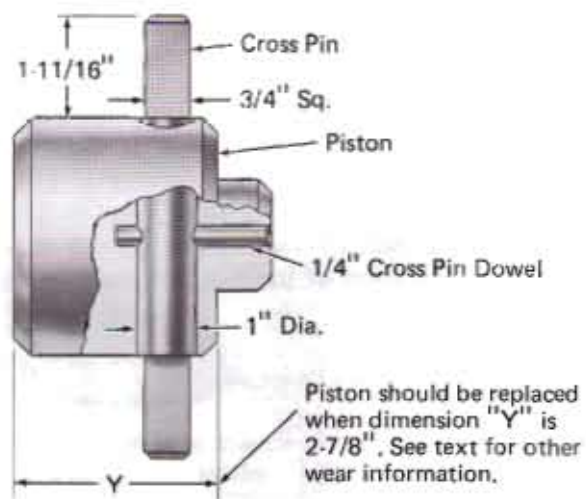

11625

Piston And Cross Pin – Six Wheel Truck

Fig. 11 – Spring Friction Devices

following procedure. Fig. 11 shows construction of the pin and provides the information needed for assembly of the pin in the piston.

1. Center punch the cross pin dowel at the end. Drill and tap it for a 10-24 thread 1" deep.
2. Apply a number of washers under the head of the 10-24 bolt and use the bolt as a puller to remove the cross pin dowel.
3. Remove the worn cross pin and apply a new pin using the dimension shown in Fig. 11.
4. Drill the new cross pin to receive a new dowel using the hole in the piston as a guide. The hole in the cross pin should be about .001" smaller than the new 1/4" dowel.
5. Insert a new cross pin dowel to securely hold the cross pin.

Center Bearing Wear Plates

The bolster center bearing on each truck supports half the weight of the locomotive. Also, the bolster center bearings transfer motive force to the locomotive carbody. The load on these parts and the relative movement between them will cause the parts to wear.

As mentioned previously, side bearing clearance close to the limit is an indication of wear at the center bearing wear plate. The rebuild and condemning limits of the center bearing wear plate are shown in Fig. 12. The thickness of the wear plate should be checked whenever the plate is accessible. When the plate reaches the condemning limit, it should be replaced by a new plate. If the thickness of the plate is greater than the rebuild limit, it may be re-used. However, if the thickness is less than the rebuild limit, it should be replaced with a new plate. The purpose of the rebuild limit is to ensure ample thickness of the plate to allow for wear until the next inspection, without exceeding the condemning limit.

The outside diameter of the carbody center plate assembly and inside diameter of the bolster center bearing should be compared or the clearance between these parts should be checked to determine the total clearance between these parts. Recommended clearance between these parts is shown in Fig. 12. When assembling these parts, the rebuild clearance limit of 1/8" between these parts should not be exceeded. The maximum or condemning limit between these parts is 1/4", Fig. 12.

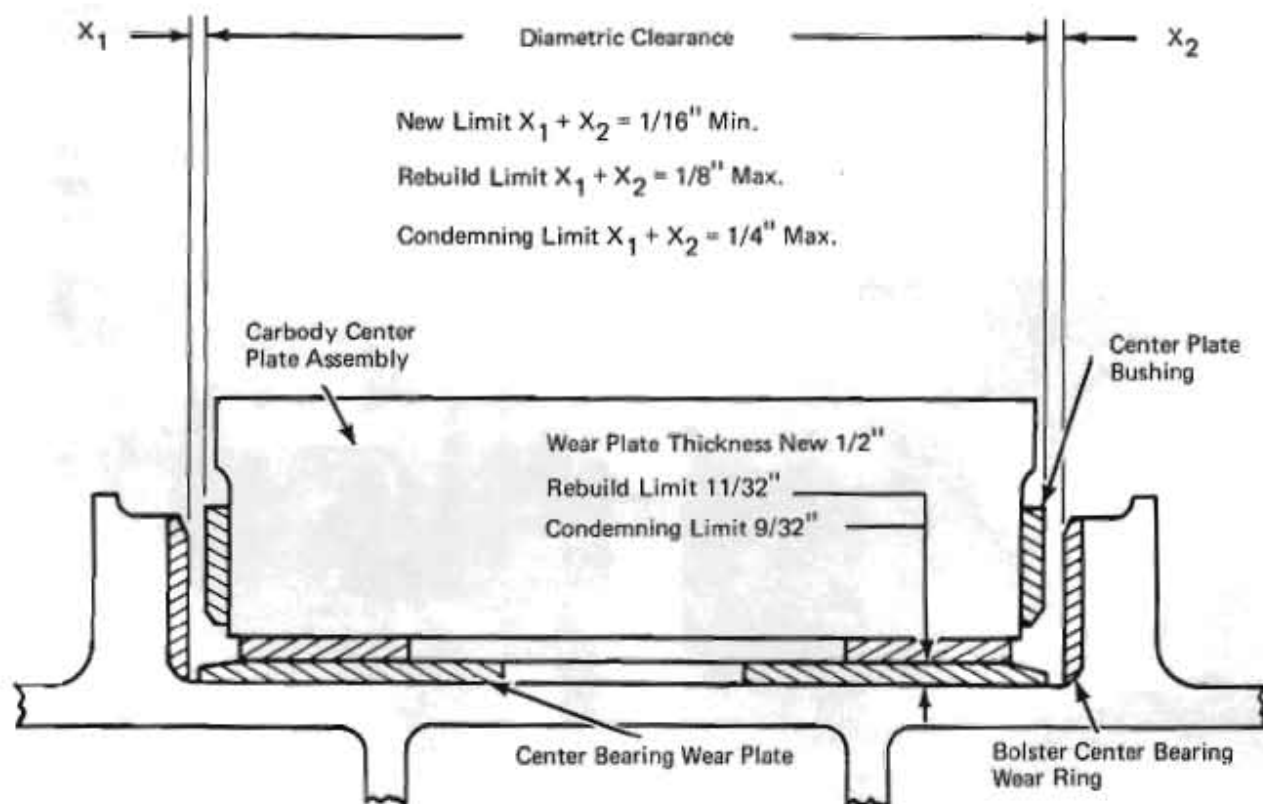

18908

Fig. 12 - Bolster Center Bearing Clearance

Center bearing wear plates and wear rings are made of 1/2" thick laminated phenolic material.

Check the center bearing area of the bolster to make sure there are no cracks or voids which might allow lubricating oil to leak out. If any cracks are found, they must be completely removed by arc air cutting, flame cutting, chipping, or grinding and a 60° "V" groove provided for welding. Weld the crack with AWS-E-7016 electrode. Peen the second weld pass and each pass thereafter to minimize distortion. Grind off excess weld metal so the surface of the center bearing plate will be flat within .020".

After the old wear plates and wear rings are removed and the necessary repairs made, the bearing bore should be cleaned and the surfaces smoothed so they offer little resistance to the application of the new replacement half rings. Check the replacement half ring surfaces to see that they are smooth. Apply a lubricant to the outside diameter of the half rings and apply the half rings to the center bearing bore. The replacement half rings have an interference fit in the bore, so they must be forced into position in the bolster center casting. Apply so that the split line between the half rings will be 90° from the longitudinal centerline of the locomotive.

NOTE: At time of manufacture, the carbody center plate bushing inside diameter is machined before application, and the outside diameter is machined after application. This is not a practical procedure for field application of a replacement bushing. Special carbody center plate bushing

rings with both sides machined are available for field application.

On current model locomotives, the carbody center plates are machined on the outside and bottom surface and no bushings or wear plates are used.

Some truck assembly bolsters have been equipped with steel wear rings made of SAE1060 steel material. Worn steel rings can be removed after grinding out the weld joining the ends of the ring. After the old ring has been removed, the bearing bore should be cleaned and the surfaces smoothed so as to offer little resistance to the application of the new replacement ring.

Check the replacement ring surfaces to see that they are smooth. Apply a lubricant to the outside diameter of the ring and apply the ring to the center bearing bore. The replacement ring has an interference fit in the bore, so it must be forced in position in the bolster center bearing.

PEDESTAL LINERS

Pedestal liners, Fig. 13, absorb the wear that occurs from the relative movement between the journal bearing housing or adapter and the pedestals. For convenience of replacement, the pedestal liners are bolted to the pedestal jaws. Either Manganese steel or Nylatron pedestal liners are available.

Clearance limits between the longitudinal or lateral wear surfaces are such that, in normal operation, the clearance will not exceed the maximum in the period between truck reconditioning.

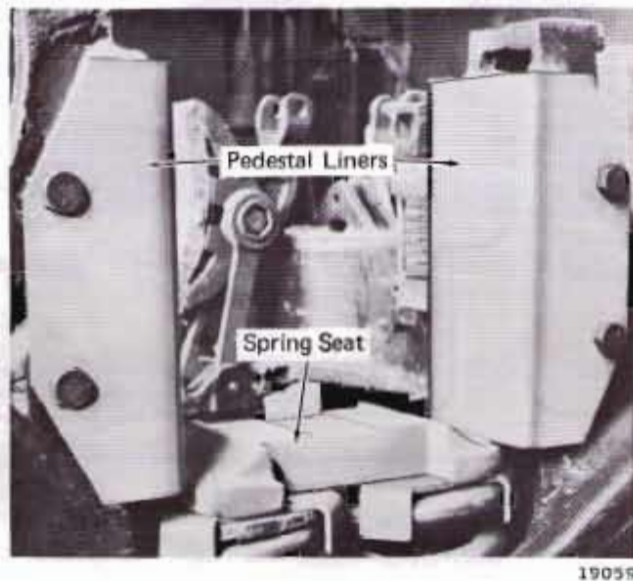
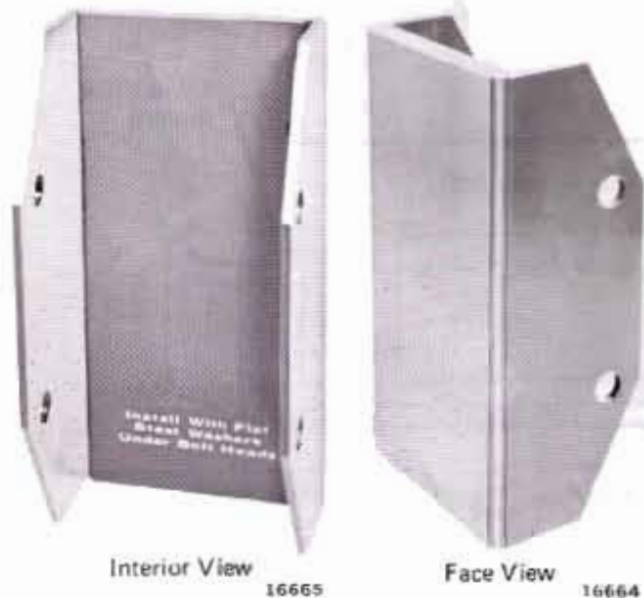
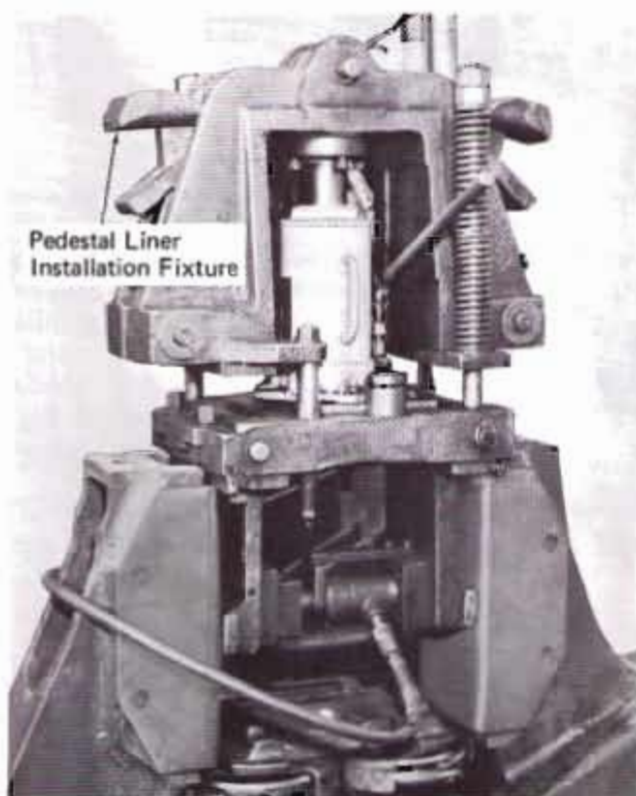

Fig. 13 - Pedestal Liners

PEDESTAL LINER APPLICATION

Inspect the pedestal jaws to be sure that the surfaces are smooth and free of any raised areas that might interfere with the application of the liners. The liners are applied as shown in Fig. 14. The liners should fit tightly on the pedestal jaw with the mounting holes mating with the pedestal bolt holes. The mounting bolts should enter the liner and pedestal bolt holes freely and should be thoroughly tightened. Particular attention should be given to the position of the worn pedestal liners before being removed so that the replacement liners can be applied in exactly the same position.



Pedestal Liner
Installation Fixture

13492

Fig. 14 - Pedestal Liner Application

The dimension between the liner faces should be 13.323"-13.385", Figs. 17 and 18. A special liner pressing tool may be made as outlined in File Drawing 649 to aid in the installation of the pedestal liners. This file drawing is available on request.

JOURNAL BEARING WEAR PLATES

Two types of journal bearings may be used. One is an oil lubricated, crowned roller box-type bearing which has the wear plates welded directly

to the housing, Fig. 15. The other is a grease lubricated, tapered roller, cartridge-type bearing utilizing an adapter to which the wear plates are welded, Fig. 16.

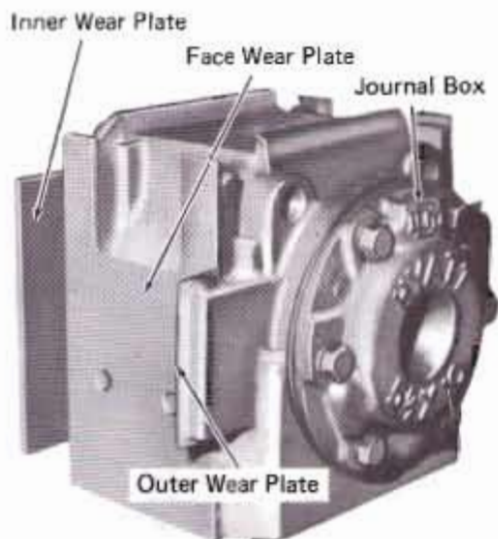

10909

Fig. 15 - Box-Type Journal Bearing

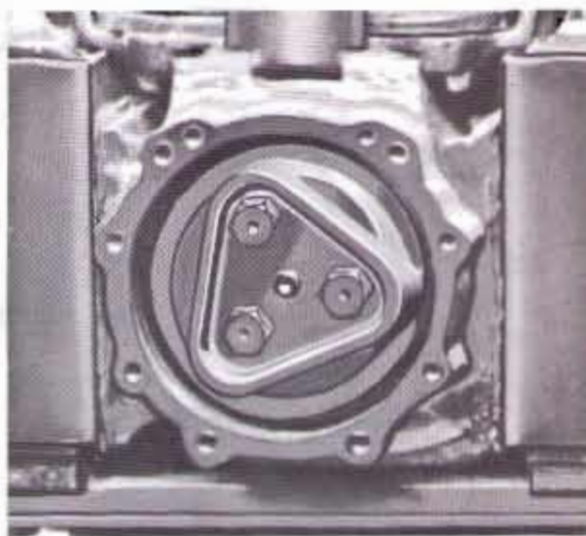

18830

Fig. 16 - Cartridge-Type Journal Bearing

Journal box housing or adapter wear plates, which are cracked or worn beyond their limits, should be replaced. The old wear plates can be removed by grinding or chipping off the welds holding the plates. The wear plates should not be removed by any form of flame cutting. Care should be taken not to damage the surfaces of the housing or adapter to which the new plates are to be applied.

Pedestal liner to housing wear limits for box-type journal boxes are shown in Fig. 17. Pedestal liner to bearing adapter clearance is shown in Fig. 18.

All parts of the journal box should be removed from the housing before applying new wear plates. The wear plates are made from steel heat treated to a predetermined hardness. AWS-E-6016 welding electrode should be used in the application of new mild steel wear plates.

AWS-E-FcMn-A welding electrode should be used with manganese steel wear plates.

All welding should be done in the down hand position with the journal box housing submerged in water, except for the area where the welds are to be applied. This procedure will tend to eliminate distortion of the housing. Welds extending beyond the wear surfaces of the plates should be ground off flush with the liner to prevent contact

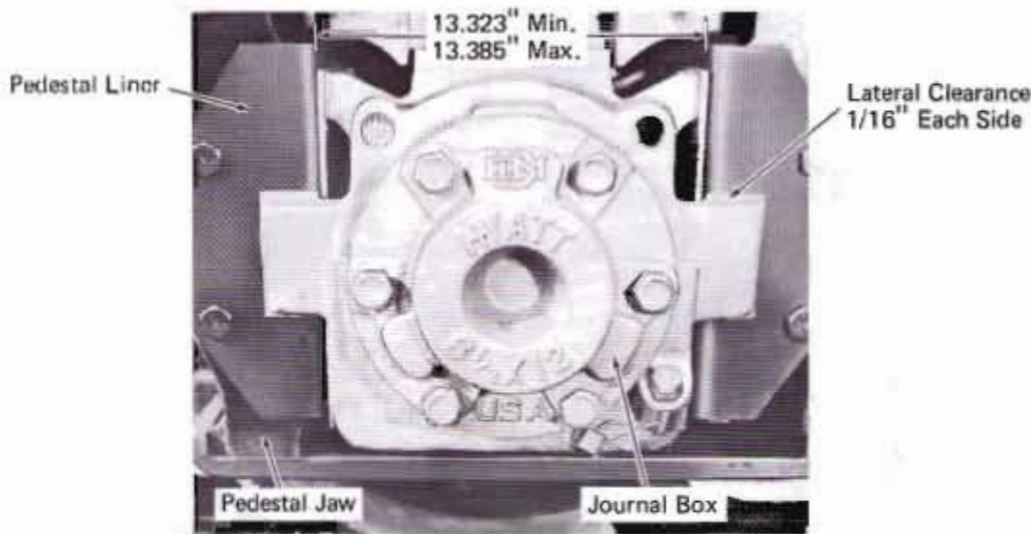

18783

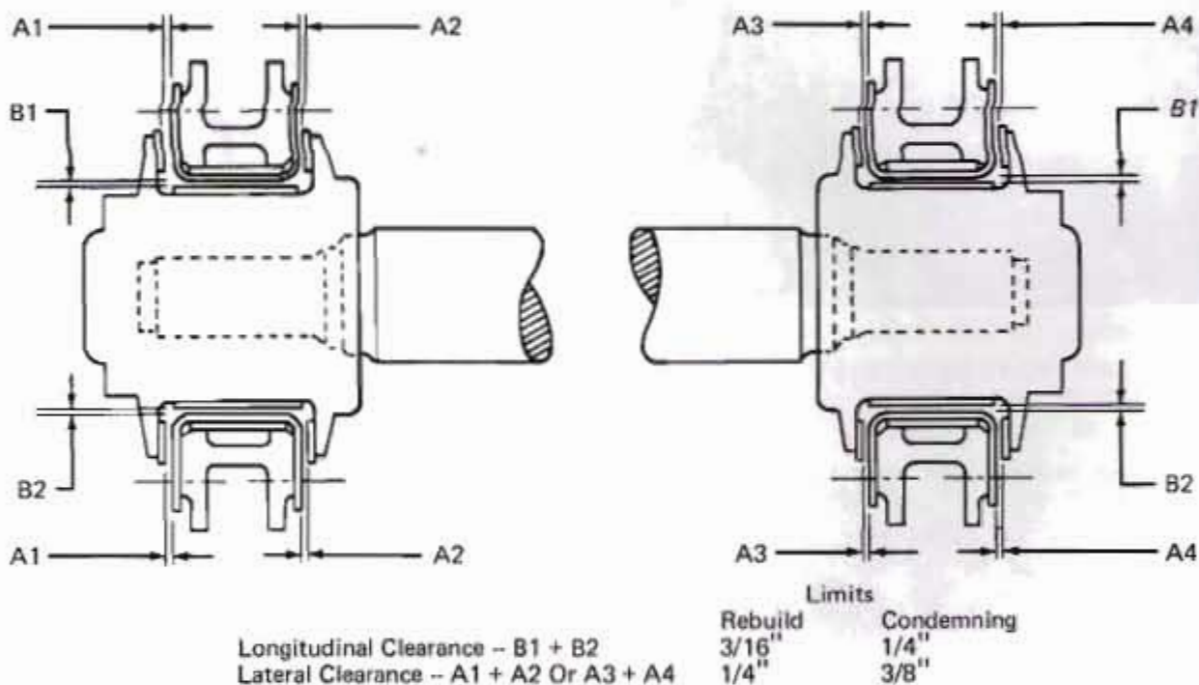

11313

Fig. 17 - Truck Pedestal To Journal Box Housing Wear Limits

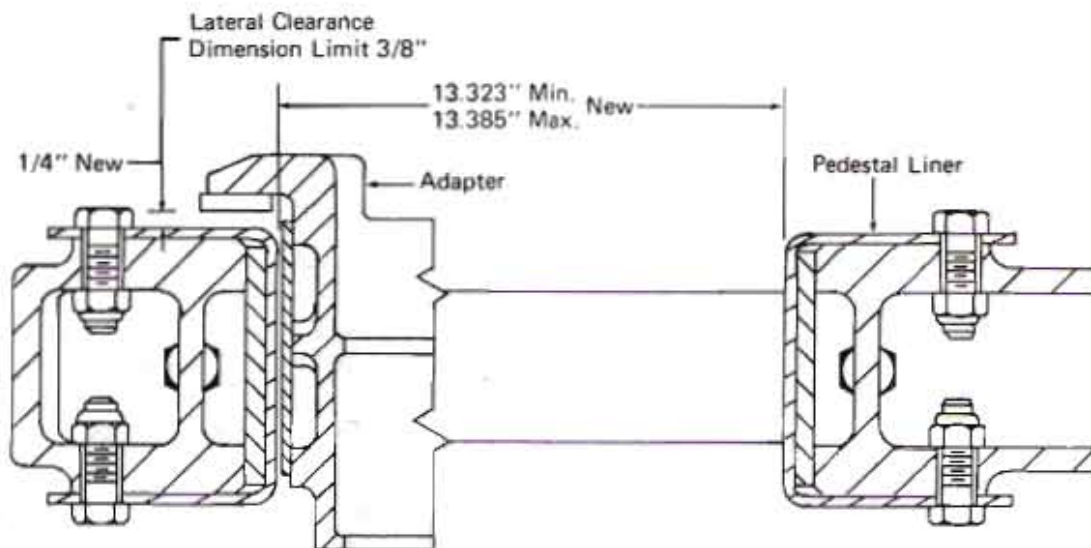

18911

Fig. 18 - Bearing Adapter To Pedestal Liner Clearance

with mating surfaces on the truck pedestals. Wear plate welding details are shown in Fig. 19. In applying wear plates that have holes provided for welding, apply the weld to the holes before welding the outer edges. This will help to ensure contact at the centers of the wear plates and prevent plate warping. Clamps should also be used to hold the wear plates tight against the journal box, while they are being applied.

The cartridge-type journal bearing should be removed from the adapter before applying new

wear plates. The wear plates are made of either mild steel or manganese steel. Welding electrode AWS-E-FeMn-A should be used in the manganese steel wear plate application. If mild steel wear plates are used, AWS-E-6016 welding electrode should be used. See Fig. 20 for welding details.

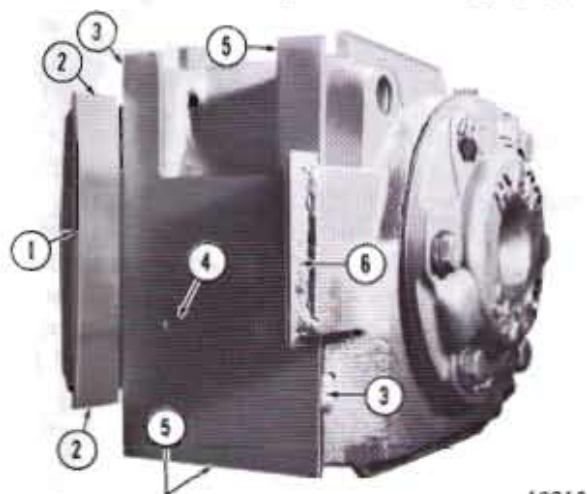

18912

1. 1/4" Fillet weld 4" long centered on 5" flut surface
2. 1/4" Fillet weld
3. Butt weld 1" long on 13-1/2" centers
4. 3/16" Fillet weld all around
5. 1/4" Fillet weld 2" long on 5-1/2" centers
6. 1/4" Fillet weld - 3 sides

Fig. 19 - Details For Welding Wear Plates To Journal Box Housing

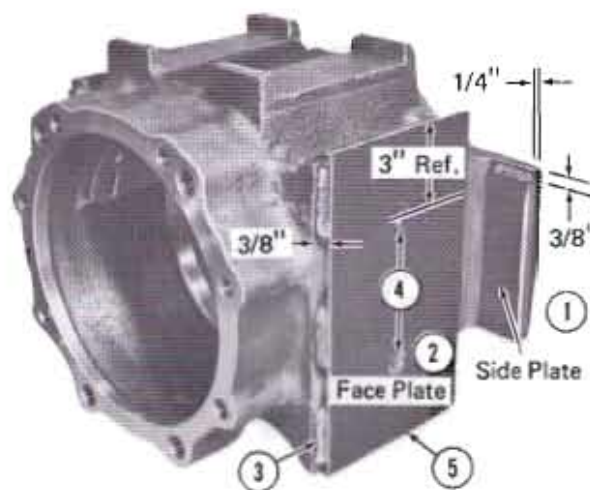

17438

1. 3/16" Bevel Weld 1-1/2" Long
2. 3/16" Bevel Weld On Both Ends
3. 3/16" Bevel Weld On Both Sides, Increments 2" Long On 4-1/2" Centers
4. 3/16" Bevel Weld Around Inside Of Each Hole
5. 3/16" Bevel Weld, Increments 1-3/4" Long On 5" Centers On Both Ends

NOTE: Beveled edges of side plate to be assembled towards outside as shown.

Fig. 20 - Journal Bearing Adapter Wear Plate Welding Details

The weld should be made with proper current to obtain a weld slightly convex and without craters. Welds extending beyond the wear surfaces of the plates should be ground off flush with the liner to prevent contact with mating surfaces on the truck pedestals.

When applying wear plates that have holes provided for welding, apply the weld to the holes before welding the outer edges. This will help to ensure contact at the centers of the wear plates and prevent warping. Clamps should also be used to hold the wear plates tightly against the bearing adapter while they are being applied.

The outside dimension across the adapter wear plates, using new plates, should be $13.310'' + .000'' - .050''$. The inside dimension between the pedestal liners is $13.323'' + .062'' - .000''$. These dimensions provide for a maximum longitudinal clearance of $.125''$ or a minimum clearance of $.013''$ when all new parts are used. The rebuild limit between these parts is $3/16''$, and the condemning limit is $1/4''$.

TRACTION MOTOR NOSE SUSPENSION ASSEMBLY

SUSPENSION PACKS

Each time power is applied to the traction motors, the pinion of each motor tries to ride around the axle gear, raising the motor up or pulling it down, depending on the direction of motion. This movement of the motor is arrested by securing the motor to the truck frame transom through a shock damping rubber suspension pack, Fig. 21.

WEAR PLATES

The wear plates on the suspension assembly are subjected to severe shocks and tremendous pressures, causing them to wear, resulting in free movement between the traction motor frame and the suspension assembly. As this movement increases, due to wear, the severity of the shocks increases, especially during the rapid changes of torque caused by wheel slip.

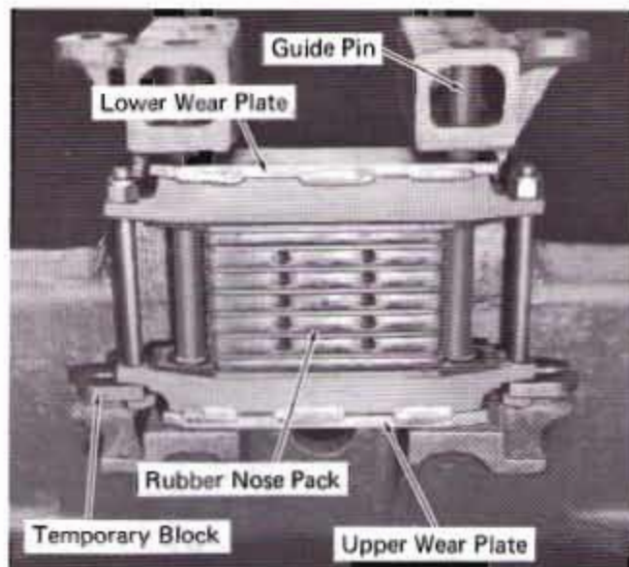

13476

Fig. 21 – Traction Motor Nose
Suspension Assembly

To obtain maximum cushioning effect from the suspension pack, wear plates should be periodically replaced to ensure there is not more than $1/4''$ free movement in the traction motor nose suspension. If the wear plates, which are $1/2''$ thick when new, are worn enough to permit more than the $1/4''$ free movement, or if the wear plates are worn more than the limits given in Fig. 22, the suspension pack should be removed and the wear plates replaced.

The upper wear plate is identical to the lower wear plate, which has a minimum limit of $7/16''$. The lower wear plate may be removed to the upper position if it is still within the $13/32''$ upper wear plate limit.

The old wear plate can be removed from the spring pack by grinding or chipping off the tack welds holding it. The new wear plate should conform to the dimensions of the original plate.

The manganese steel wear plate should be applied to the suspension pad with $3/8''$ fillet welds $2-1/4''$ long, spaced $3-3/4''$ apart. When welding manganese steel wear plates use an AWS-E-FeMn-A welding electrode.

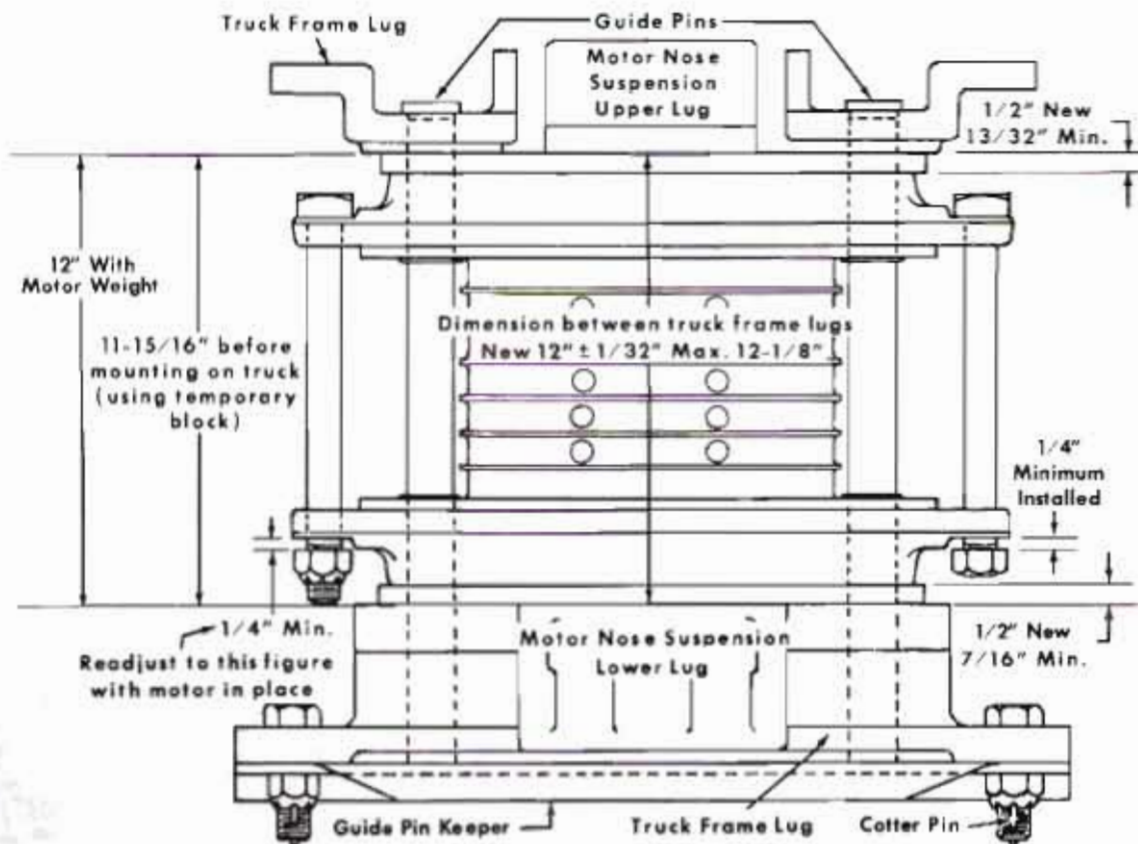

Fig. 22 - Traction Motor Nose Suspension Wear Plates

MOTOR NOSE SUSPENSION LUGS

The lugs on the truck frame transom that support the traction motor suspension assembly are subject to wear due to the chafing of the suspension assembly. The maximum dimension between these surfaces is 12-1/8" as shown in Fig. 23. If this limit is exceeded, it will be necessary to build up the lug faces, by welding and machining or grinding, to obtain the original dimension of 12" ± 1/32". The ground or machined surfaces of the lugs should be in the same plane within 1/32".

Current practice is to install a 3/16" thick manganese steel wear plate on each of the four truck frame suspension lugs. If manganese wear plates are used on the suspension assembly, they should also be used on the suspension lugs. This will reduce wear at these points and allow an extended period between rework. The wear plates are applied to the lugs with a 3/16" fillet weld using an AWS-E-FeMn-A welding electrode. Weld the plate on three sides as shown in Fig. 23. After the wear plates are applied, the surfaces must still be in the same plane and the dimension between the upper and lower lugs must be 12" ± 1/32".

The guide pin holes in the frame lugs should be checked for size. The holes are drilled to a nominal 1-5/16" diameter when new. If they become worn or elongated by 3/32" or more,

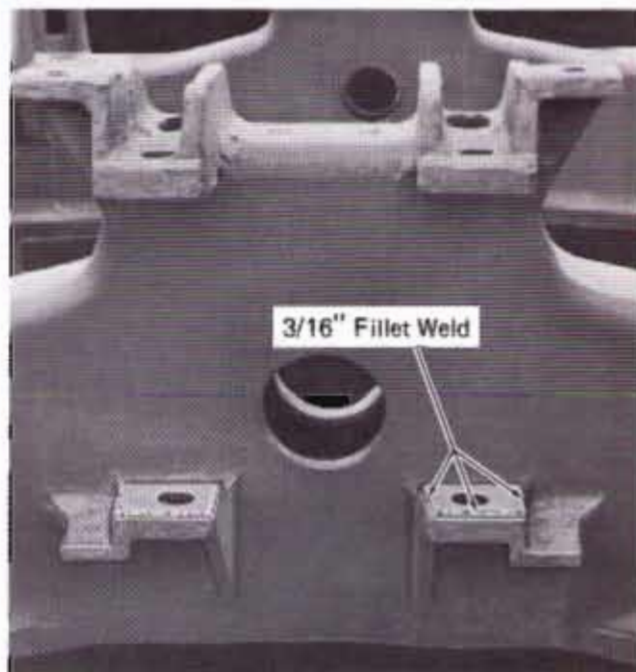

Fig. 23 - Truck Frame Motor Nose Suspension Lugs

they must be ring or plug welded and redrilled to the correct dimension. An optional method of repairing the guide pin holes is to drill the worn holes to $1.875'' \pm .002''$ and press in bushing 8308240. Weld the bushing to the support lugs after it is pressed into position. The guide pins are $1.250''$ in diameter when new, and should be replaced when worn to $1.220''$.

TRUCK FRAME PEDESTAL REPAIR

WHEELBASE SPACING

The wheelbase spacing is the measured distance between the transverse centerline of the truck and the transverse line between the jaws of the pedestals or the dimension between the axle centerlines. These dimensions are shown as "X" in Fig. 24 for a four wheel truck and Fig. 26 for a six wheel truck.

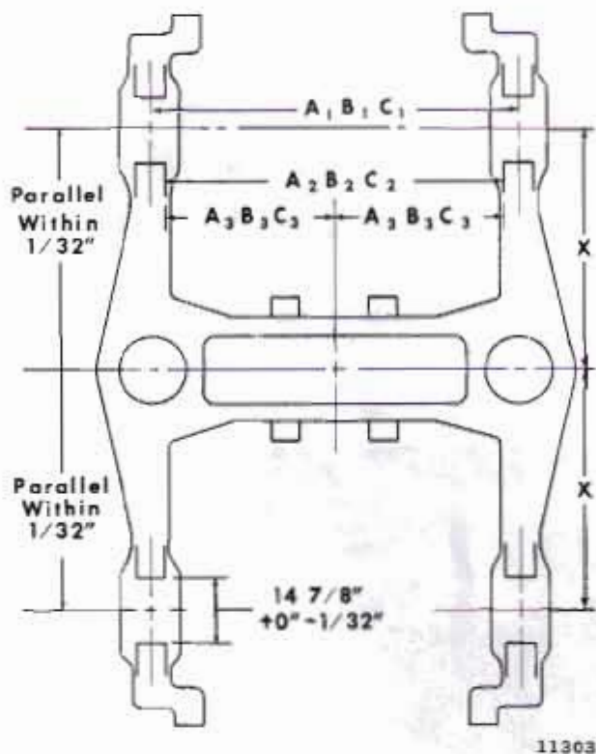

$A_1 - 63-1/2'' \pm 1/16''$
 $B_1 - 77'' \pm 1/16''$
 $C_1 - 86-1/2'' \pm 1/16''$

$A_2 - 56-17/32'' \pm 1/16''$
 $B_2 - 70-1/32'' \pm 1/16''$
 $C_2 - 79-17/32'' \pm 1/16''$

$A_3 - 28-17/64'' \pm 1/32''$
 $B_3 - 35-1/64'' \pm 1/32''$
 $C_3 - 39-49/64'' \pm 1/32''$

Fig. 24 - Four Wheel Truck Frame Measurement

Locate the truck frame transverse centerline or the middle axle centerline to obtain the wheelbase spacing. This can be accomplished by centering a straightedge between the machined surfaces to which the bolster chafing plates are welded on a four wheel truck, or measuring between the middle pedestals on a six wheel truck.

On four wheel trucks the wheelbase dimension is obtained by placing a straightedge along the face of the pedestal jaw and measuring to the centerline of the straightedge at the transverse centerline. To this dimension, add one-half the distance measured between the pedestal jaws at the approximate center of the pedestals. This will give the "X" dimension shown in Fig. 24.

On six wheel trucks, measure the distance between the pedestals as shown in Fig. 25. This will give the "X" dimension shown in Fig. 26.

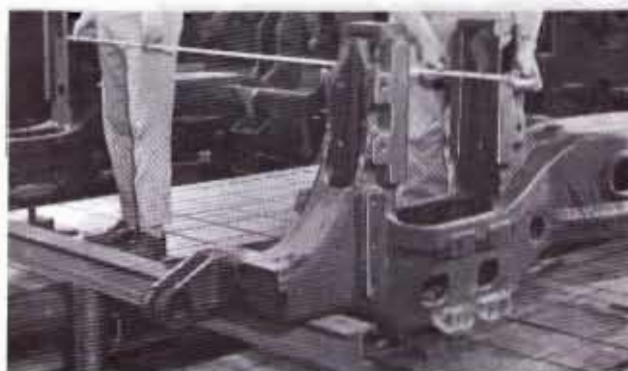
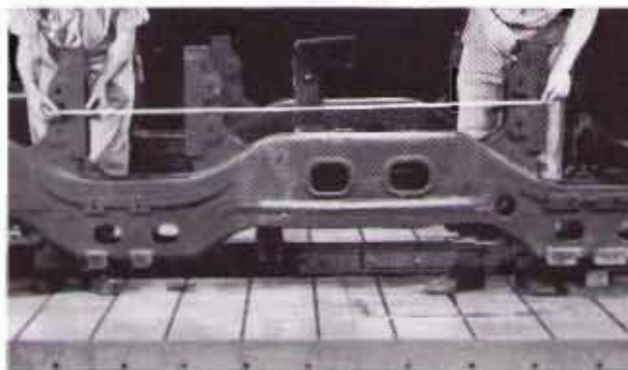

Fig. 25 - Measuring Wheel Base Dimension And Transverse Pedestal Spacing

The new wheelbase dimensions and service limits for all trucks are given in Table A.

TRANSVERSE PEDESTAL SPACING

The transverse pedestal spacing refers to the dimension between the inside machined surfaces of pedestal jaws on opposite sides of the truck,

TABLE A
WHEELBASE DIMENSIONS

| Truck Designation | Wheelbase "X" Dimension In Figs. 24 & 26 | | | |
|---------------------------|--|-------------------|--------------------|-------------------|
| | New | | Limit | |
| B-B Four Wheel-Two Motor | 48" ± 1/16" | | 48" ± 1/8" | |
| A1A Six Wheel-Two Motor | 63" ± 1/16" | | 63" ± 1/8" | |
| | Short End Of Truck | Long End Of Truck | Short End Of Truck | Long End Of Truck |
| C-C Six Wheel-Three Motor | 66-1/2" ± 1/16" | 79-1/2" ± 1/16" | 66-1/2" ± 1/8" | 79-1/2" ± 1/8" |

or between the inside machined surface of the pedestal jaw and the longitudinal centerline of the truck. These dimensions are determined by the rail gauge and are designated in Figs. 24 and 26 as A₂, B₂, C₂ and A₃, B₃, C₃. The transverse measurements may be made as shown in Fig. 25. The dimensions A₂ and A₃ refer to narrow gauge trucks (meter gauge 39-3/8" and 3' 6" gauge). The B₂ and B₃ dimensions refer to standard gauge trucks (4' 8-1/2"). The C₂ and C₃ dimensions refer to broad gauge trucks (5' 3" and 5' 6"). (There is an exception to standard gauge truck 8228607 equipped with truck frame 8230010. On this frame, B₂ dimension is 71-1/32" and C₂ is 35-17/32".)

There is a tolerance of ± 1/16" on the dimension designated A₂, B₂, and C₂ while a ± 1/32" tolerance may be applied to the A₃, B₃ and C₃ dimensions on the respective trucks. The pedestals may lean "in" or "out," providing both pedestals of each set lean in the same direction, and are within the plus or minus tolerance allowed from the longitudinal centerline of the truck frame to the inside face of the pedestal. For example, the A₂ dimension may be from 56-19/32" to 56-15/32", while the A₃ dimension may be 28-19/64" to 28-15/64".

Pedestals which do not conform to the dimensional limits can be corrected by straightening the truck frame, hot or cold.

LONGITUDINAL PEDESTAL SPACING

The longitudinal pedestal spacing refers to the distance between the inside surfaces of the pedestal jaws, as indicated in Figs. 24 and 26. This dimension is 14-7/8" + 0" - 1/32".

Incorrect pedestal spacing is caused by a bent frame or bent pedestals, either of which would require stratching to bring the pedestal spacing within the limits.

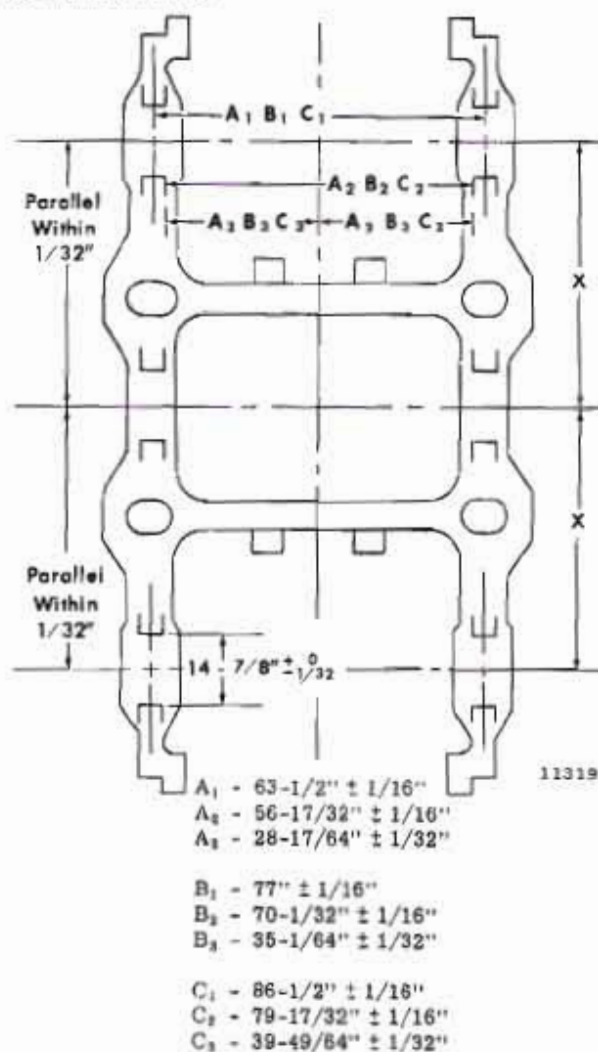

Fig. 26 - Six Wheel Truck Frame Measurement

HORIZONTAL PEDESTAL ALIGNMENT AT THE BASELINE

The horizontal pedestal alignment at the baseline is the relationship of one pedestal jaw to any other pedestal jaw on the truck frame, as indicated in Fig. 27. This alignment can be determined by measuring from a straightedge tool or piano wire spanning the pedestals. Re-alignment of a misaligned condition can only be accomplished by straightening the truck frame.

LOCATION OF JOURNAL BEARING COIL SPRING SEATS

The centerline of the coil spring retainer seats should be held within 1/8" either side of the centerline of the pedestal opening, as indicated in Fig. 27. The coil spring seat location should be checked for alignment when any rework is done on the pedestals.

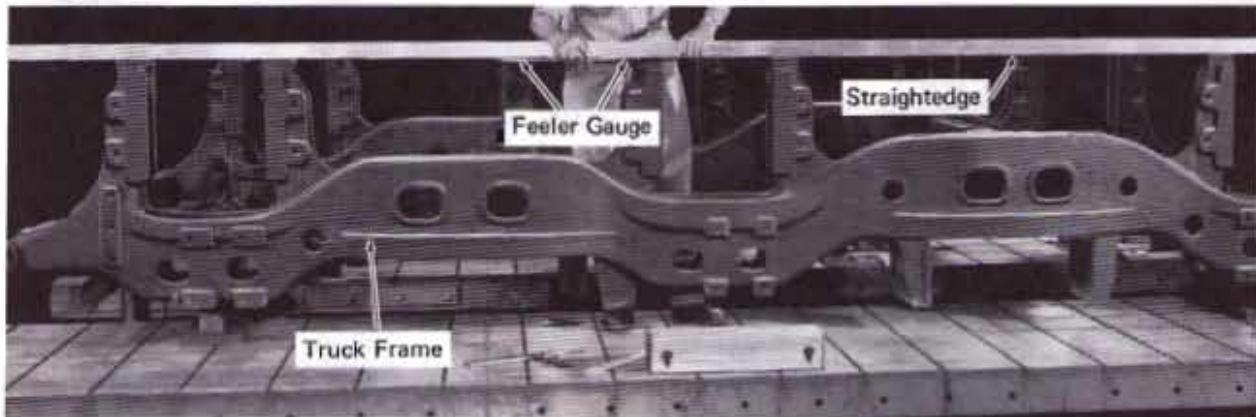

11250

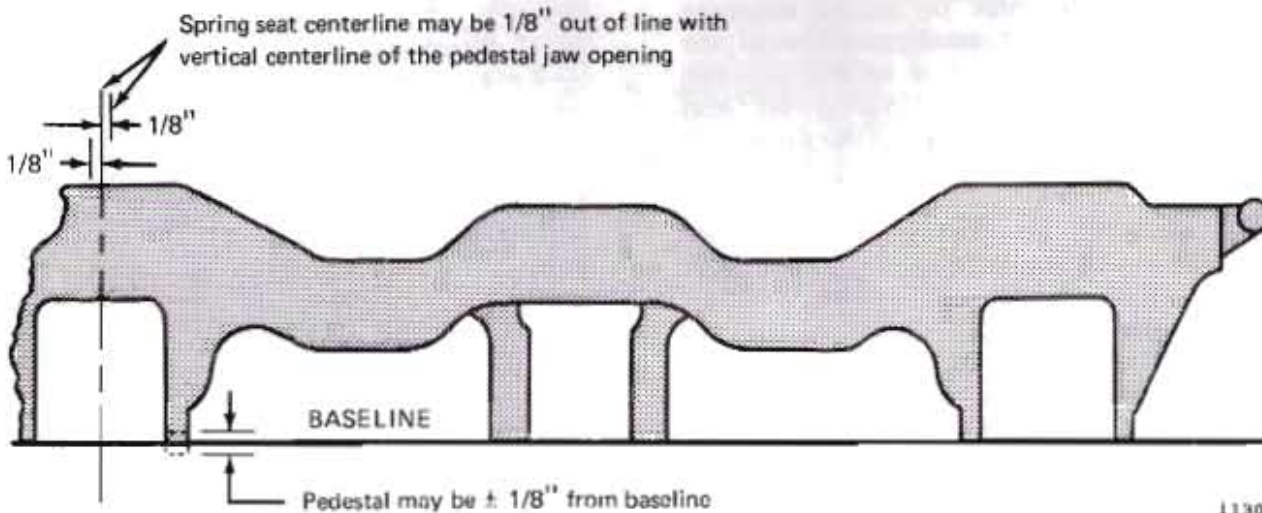
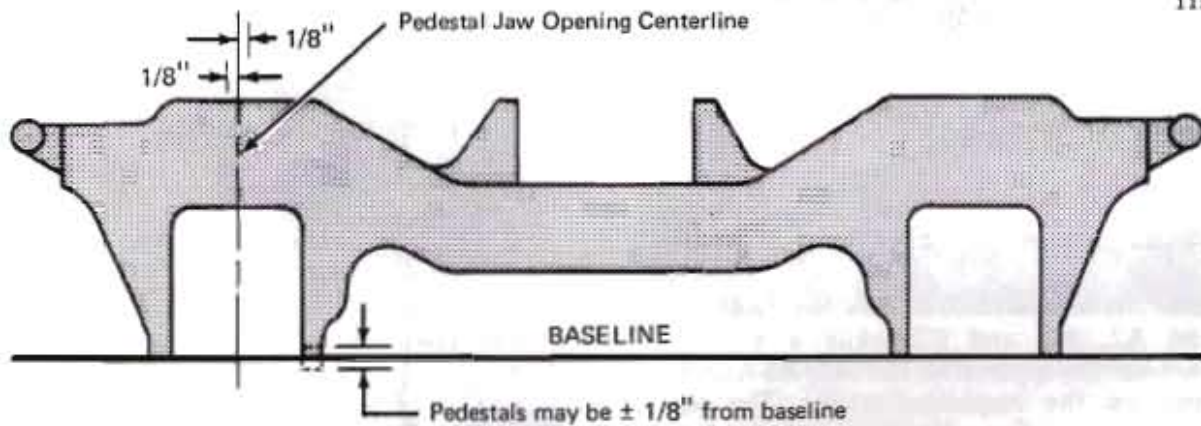

11305

Fig. 27 - Pedestal Base Horizontal Alignment

If the misalignment is more than 1/8", it may be corrected as indicated in Fig. 28. A section of each of the two spring seat flanges is flame cut

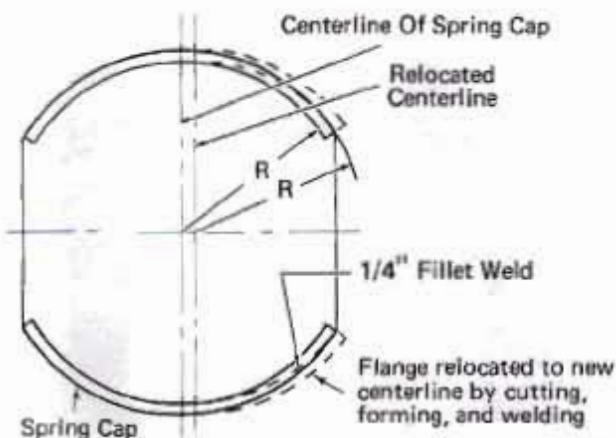

11320

Fig. 28 - Relocation Of Spring Seat Centerline

and spread to accept the coil spring on the new center.

Reweld the flanges after they have been spread to the new location.

Grind the new welds smooth so that no high spots remain which would cause localized loading on the coil springs.

TRAMMING OF TRUCKS

The truck pedestals are trammed to determine if they are in correct alignment with each other, that is, to determine if the distance between pedestals is equal or within the allowable dimensional limit. The diagrams shown in Fig. 29 indicate which pairs of the pedestals should have equal distances between them, on the four and six wheel truck frames.

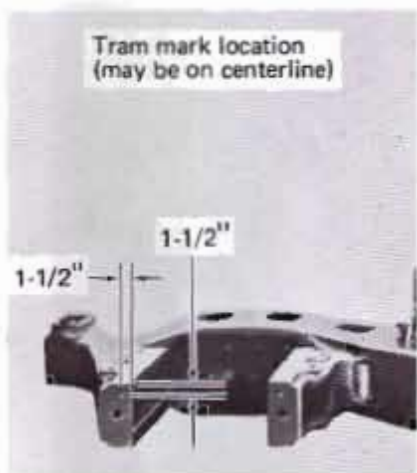

11616

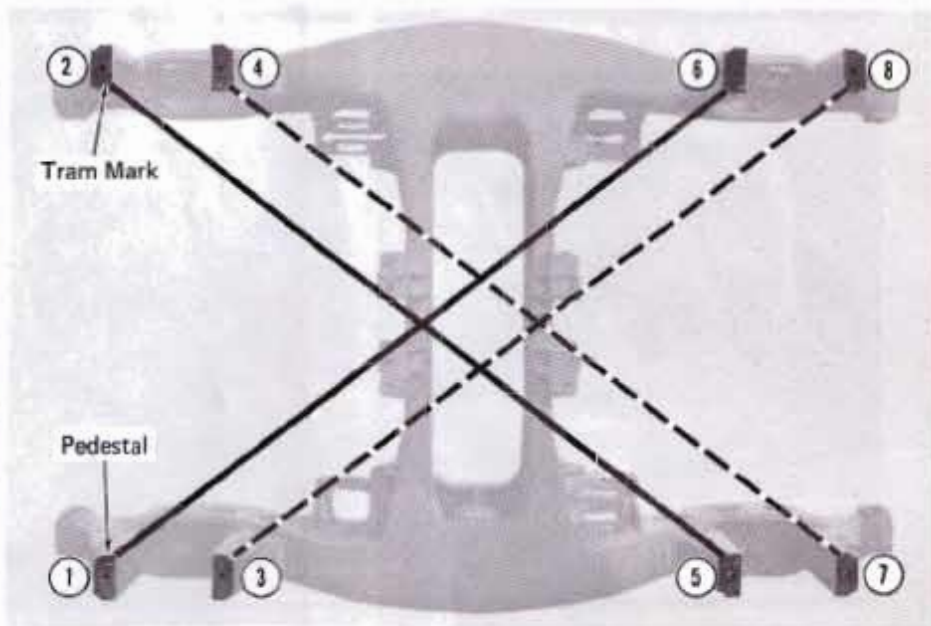

11549

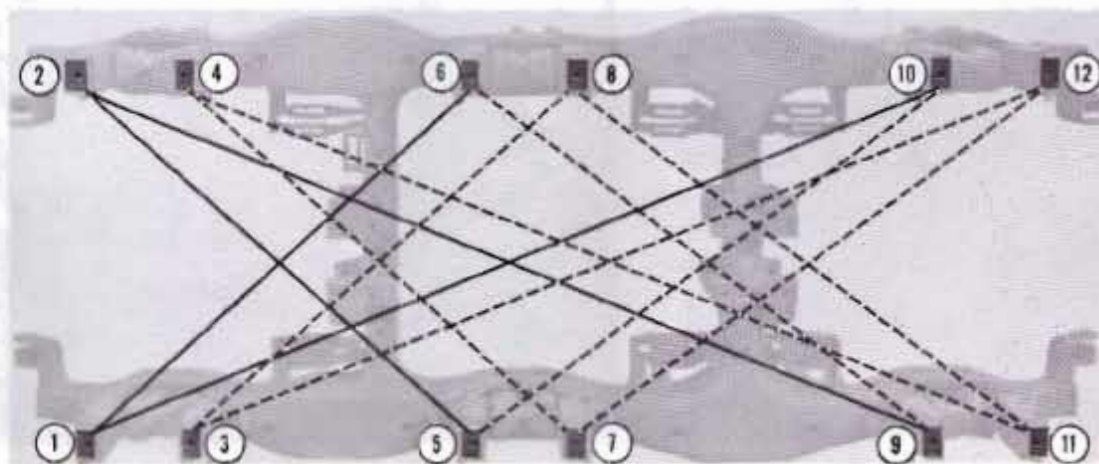

11482

Fig. 29 - Truck Frame Tramming Diagrams

Tramming is accomplished using a trammel beam as shown in Fig. 30 with the truck frame inverted on a level table or level location. In addition to the equal diagonals shown in Fig. 29, it may be

necessary to check the tram of the pedestals both longitudinally and transversely as indicated in Fig. 30.

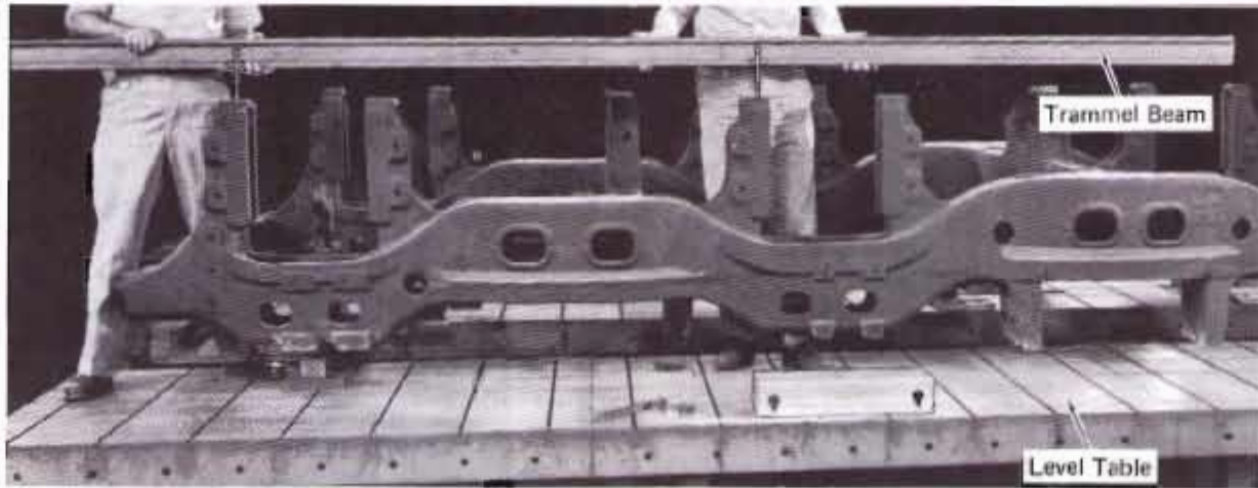

11252



11249

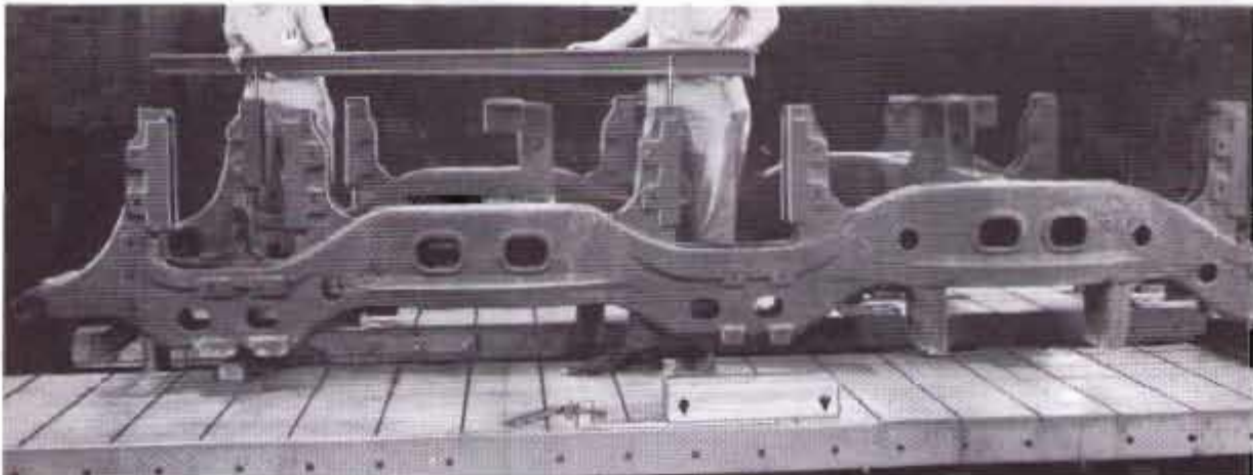

11255

Fig. 30 - Application Of Trammel Beam Between Pedestals

The tram assembly is made up of two trammels attached to a wooden or metal beam that will hold the assembly rigid. This assembly facilitates taking comparative measurements of varying lengths, which could not be done using conventional dividers. The adjustable trammels permit any distance separation on the beam, so as to compare the various dimensions which are to be trammed.

Tram marks are made on the end or bottom of each pedestal at the time of original tramping during manufacture of the truck frame. These marks, which are small punch indentations, are placed at identical locations on each pedestal so as to ensure an accurate comparison. They may be either 1-1/2" from each inside face of the pedestal or on the longitudinal centerline of the pedestal just inboard of the tie bar bolt hole. The mark must be made at an identical location on each pedestal.

A special tool shown in Fig. 31 for locating the tram marks on the pedestal can be made according to information furnished in File Drawing 615, available on request. This tool is used to make two scribe marks at right angles to each other at the 1-1/2", or other required dimension, on the bottom of the pedestal. The hardened end of the scriber on the tool is placed at the intersection of the scribe lines, and is tapped lightly with a hammer, so as to make a small indentation in the metal for the tram points. The bottom of the



11248

Fig. 31 - Tram Marking Tool

pedestal should be clean before marking. Also, an application of blue layout dye, to the area of the pedestal to be marked, will aid in scribing the lines and locating the tram marks.

It will be necessary to relocate the tramping mark, after obliterating the old mark, in the event of rework on the truck, such as straightening of bent pedestals.

The truck frame should be leveled before tramping. Support the truck frame on two small jackscrews under the pedestal spring pockets at one end of the frame and by one jackscrew or hydraulic jack placed on the longitudinal centerline at the opposite end of the frame, similar to the support shown in Fig. 30. It will be necessary to bridge the sides of the frame or trucks without end sills so as to accommodate the jack at the frame longitudinal centerline. The end supported by the two jacks is raised to any convenient height, and measured at the top of the end pedestals as shown in Fig. 32. The end pedestals at the center supported end of the frame are brought up to the same height as the other end. If one pedestal cannot be brought up to a height equal to that of the other pedestal, it indicates that the frame has a slight twist at the end of the lower pedestal.

Each pedestal should also be checked for leaning, before tramping at the inside surface and the side toward the center of the truck. That pair of pedestals opposite each other (one on each side of the frame) which are found to be square or

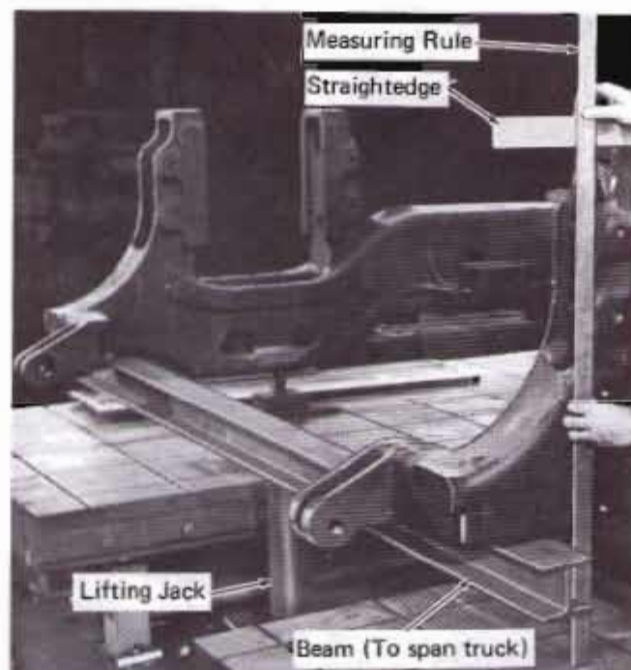

11253

Fig. 32 - Leveling Truck Frame

nearly so, are used as starting points for tramping. The pedestals are checked using a straightedge and square, as shown in Fig. 33.

If the diagonal measurements shown in Fig. 29 are not equal, it will be necessary to tram the pedestals longitudinally and transversely, as shown in Fig. 30, to locate and determine how much the pedestals are out of alignment.

A typical example of the tram measurements for a six wheel truck is shown in Fig. 34. Diagonal trams are shown to be unequal as follows: 3-8 ($1/8''$), 1-6 ($0''$), 2-5 ($1/32''$), and 4-7 ($1/16''$) with 3-8 being in excess of the $1/16''$ limit. Pedestals 3-8 are out of alignment either longitudinally or transversely. Tramping indicates that longitudinally all the pedestals are equal as indicated by the $0''$ measurements. Transverse tramping indicates that pedestals 7-8 are equal to pedestals 1-2, but 5-6 and 3-4 are wider than the other two pair by $1/16''$ and $7/32''$ respectively.

Since pedestals 3-4 are $7/32''$, it accounts for the $1/8''$ and $1/16''$ length of diagonal trams 3-8 and 4-7 going to these pedestals. Since the $1/8''$ measurement of 3-8 is twice the $1/16''$ of 4-7, pedestal 3 should be bent inboard twice as much as pedestal 4. If pedestal 3 is bent inboard $5/32''$ and 4 is bent inboard $1/16''$, diagonals 3-8 and 4-7 will be reduced, and 3-8 will be within the $1/16''$ limit. The same action would be indicated for pedestals 5-6 if it were necessary to bring diagonals 1-6 or 2-5 within limits.

TRUCK SPRINGS

Various combinations of coil springs are used at the truck bolster and pedestals, because of variable loads which may be applied on the axles.

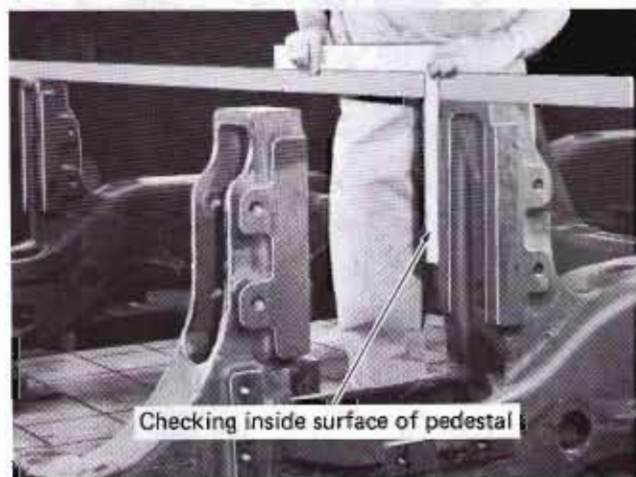

11247

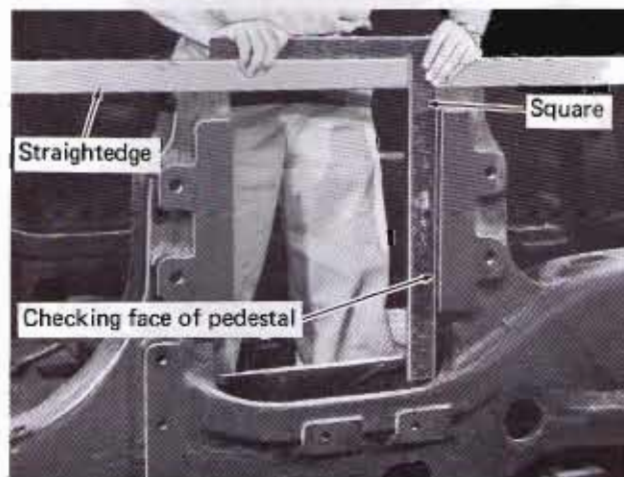

11254

Fig. 33 – Checking Pedestal Squareness

Shim plates and shims of different thickness also may be used between the spring seat and journal box so as to maintain the coupler height. The parts list provided with the customers particular order outlines the part numbers of the spring assemblies and associated parts used on the truck. It is very important to identify each of the springs according to their part number in the parts list so as to test the spring at the proper load value as listed in Service Data at the end of this instruction.

Determine if the springs are within the allowable limits given for the static load placed on the spring. Spring assemblies consisting of more than one spring should be wired together until application to ensure correct assembly.

COLOR CODING

A color code is used to indicate the loaded height of new springs. Brown paint is applied on springs or spring assemblies that are more than $1/16''$ but do not exceed $3/16''$ above the nominal static height specified for the spring. Nominal height is the spring height which is used for purposes of identification and as a base for the tolerance limits. Blue paint is applied on springs or spring assemblies that are $1/16''$ below to $1/16''$ above the nominal static height specified for the spring when under the specified load. Green paint is applied on springs or spring assemblies that are more than $1/16''$ but do not exceed $3/16''$ below the nominal static height specified. All new springs will fall into one of the above three color codes.

White paint should be applied to springs or spring assemblies that are $3/16''$ to $5/16''$ below the nominal static height specified for the spring.

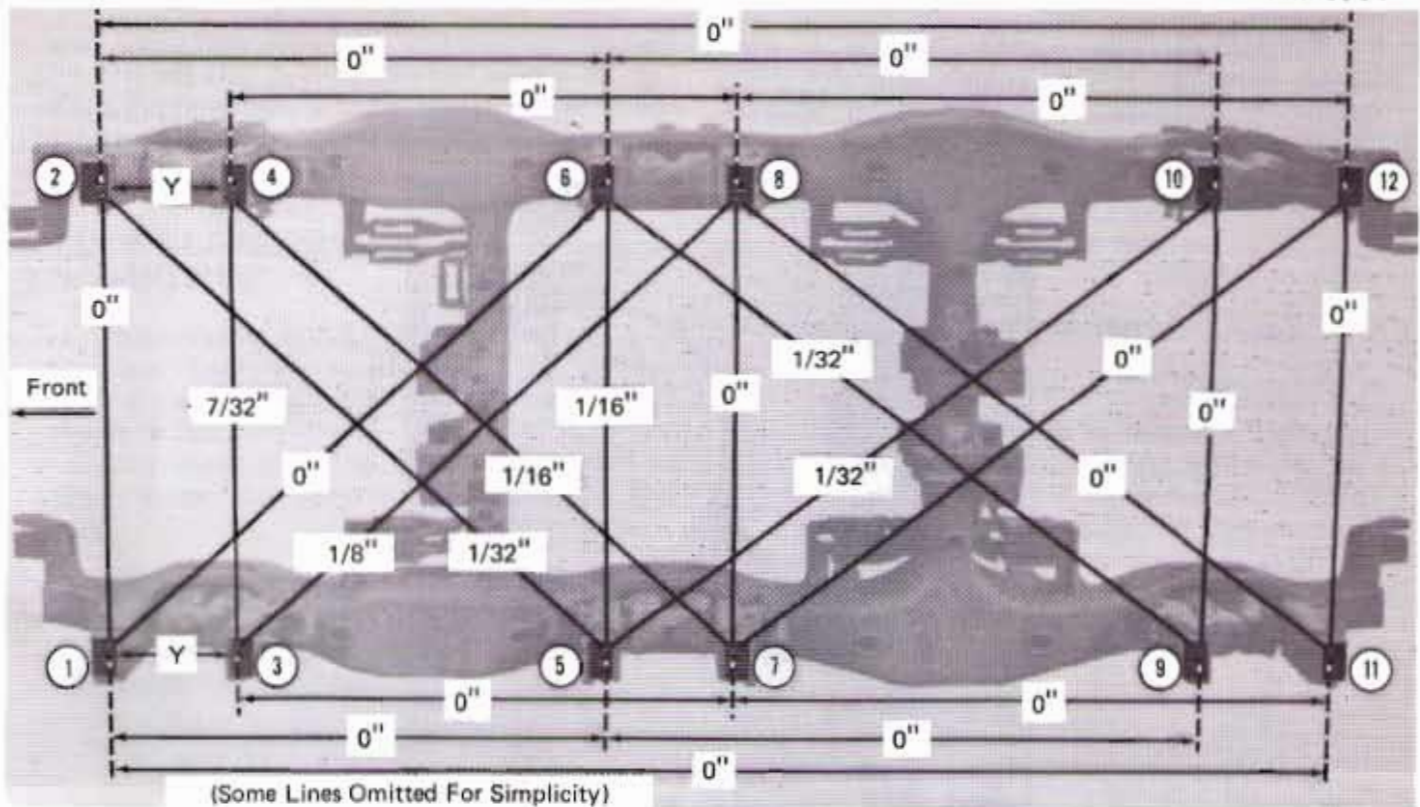

Fig. 34 – Typical Example Of Trammings Measurements On Six Wheel Truck

18913

This is a service limit and is only for use on used springs. White coded springs should be applied, with proper shims, so that their overall static height will fall within the limits of brown, blue, or green color coded springs.

Springs that have been tested, color coded and qualified for use should be stored in a protected area to avoid the formation of rust and pits. Pits can cause stress concentration that may result in spring failure when under load. The springs should be stored in groups corresponding to their color code to make their selection easier.

When coil springs are removed from a truck assembly, check them for evidence of cracked or broken coils and replace the assembly if found defective. Recommended practice is to replace both spring sets on one spring seat if any coils have failed. However, if a satisfactory loaded height can be maintained on the old spring set, then the old set may be used. Individual coils should always be matched in assemblies by color and assemblies should be matched as near as possible in trucks.

Spring groups on one spring seat should be replaced if one or more coils fail. The coils in the group which are not broken will probably have taken a set and will likely cause an overload on the new group of springs.

Springs tested at the recommended loads may be used provided they are within the following condemning limits. The condemning limits of the springs are $3/16$ " above the nominal loaded height and $5/16$ " below the nominal loaded height. Springs that are tested should be color coded as previously outlined, or otherwise identified so that springs of equal load height can be selected.

SPRING TESTING

The spring testing machine, shown in Fig. 35, may be made per File Drawing 647 for checking the springs under proper load and height. This drawing is available on request. The fixture may be used to test elliptic-type spring assemblies as well as coil springs. Safety wire mesh encloses the working parts of the fixture. Two hinged doors at the front provide access to the interior of the fixture. When the front doors are open, a movable table within the fixture can be pulled out to facilitate the application of the spring assembly to be tested. The table with the spring to be tested is pushed into place in the fixture, and the eccentric rollers supporting the table are released to provide complete support for the spring. The protective front access doors are closed and locked in place before testing. An hydraulic jack arrangement above the spring is actuated to apply a load to locate the spring at the correct height

for the test. A pressure gauge adjacent to the fixture shows the load in pounds applied to the spring, and a pointer at the side of the fixture indicates the height of the spring under test.

To operate the spring tester, the directional valve, Fig. 35, should be positioned so that the jack will compress the spring when a load is applied. The pump operating valve should then be opened to

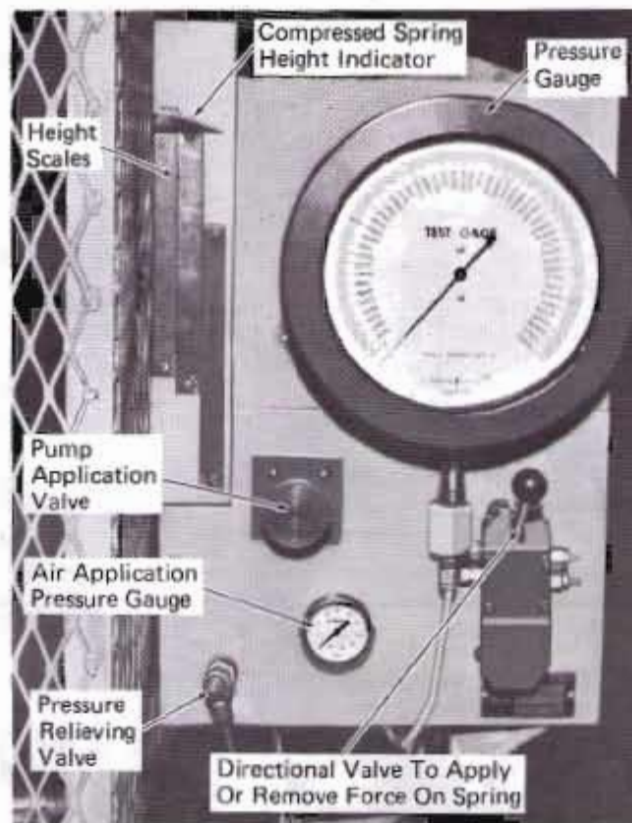

10991

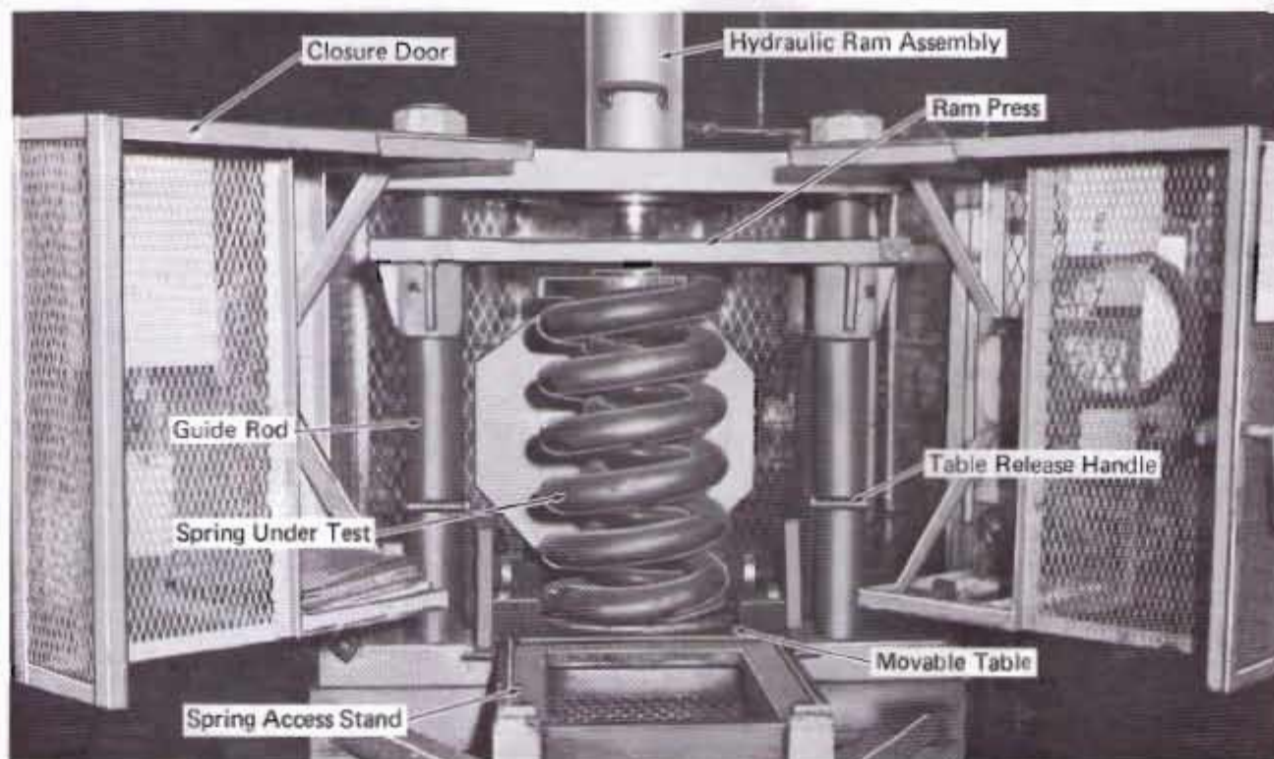

10995

Fig. 35 - Spring Testing Fixture

initiate sufficient load to compress the spring below the minimum static height (nominal static height - 5/16"). At this point, if the load is less than that specified in Service Data, the spring should be scrapped. If the static load is greater than that specified, the directional valve should be placed in the neutral or non-directional position. The relieving valve should then be opened slightly to reduce the static load to that specified in Service Data. The static height of the spring should then be measured to determine whether it falls within the specified range (nominal +3/16" - 5/16").

BRAKE RIGGING

Inspect the brake rigging to ensure that brake pins, bushings, and brake shoes are usable. The wear surfaces of the brake rigging are equipped with replaceable hardened bushings, pins, and bolts. If any of these connecting parts are worn more than 1/16" all parts should be replaced.

Cylinder levers, brake levers, and slack adjusters that are bent should be re-used only if they are

restored to their original shape. If wear is caused by the connecting strap contacting the wheel, the lever pins, bushings, and stabilizer condition and position should be carefully examined. Bolts and nuts that are not subject to wear can be re-used if they are not damaged, but cotter pins should always be replaced.

Brake shoe slack adjustment can be made by turning the slack adjuster until the brake shoe clears the wheel by at least 3/8". Brake cylinder travel should be 1-1/8".

TRUCK INSTALLATION

Installation of the truck is, in general, the reverse of removal. However, when applying a truck to a locomotive be sure that there is oil in the bolster center bearing. The oil used should conform to the specifications given in Maintenance Instruction 1756. The quantity of oil in the bearing should be sufficient to provide a level of oil 1/16" deep. Do not over lubricate. During installation of the truck, the traction motor air inlet ducts should be checked to see that they line up with the air supply ducts in the underframe.

SERVICE DATA

SPECIFICATIONS

TRUCK SPRING DATA

| Description | Part No. | Journal Springs | | Static Load Pounds |
|----------------------------|----------|-----------------|-----------------------|--------------------|
| | | Free Height | Nominal Static Height | |
| Double Coil Journal Spring | 8223561 | | 9.644" | 6434 |
| Inner Coil | 8223559 | 12.325" | 9.644" | 1594 |
| Outer Coil | 8223560 | 12.092" | 9.644" | 4840 |
| Triple Coil Journal Spring | 8232625 | | 11-1/4" | 10000 |
| Inner Coil | 8232622 | 13.64" | 11-1/4" | 1230 |
| Intermediate Coil | 8232621 | 14.35" | 11-1/4" | 2510 |
| Outer Coil | 8232617 | 14.25" | 11-1/4" | 6260 |
| Double Coil Journal Spring | 8236348 | | 13-1/8" | 5850 |
| Inner Coil | 8236349 | 15.41" | 13-1/8" | 1310 |
| Outer Coil | 8236350 | 15.35" | 13-1/8" | 4540 |
| Double Coil Journal Spring | 8241800 | | 11-1/4" | 8770 |
| Inner Coil | 8232621 | 14-3/8" | 11-1/4" | 2510 |
| Outer Coil | 8232617 | 14-1/4" | 11-1/4" | 6260 |

| | | | | |
|------------------------|---------|----------|----------|-------|
| Triple Coil | 8252513 | | 11-9/16" | 12740 |
| Journal Spring | | | | |
| Inner Coil | 8252512 | 13.31" | 11-9/16" | 1300 |
| Intermediate Coil | 8252511 | 13.77" | 11-9/16" | 3280 |
| Outer Coil | 8252510 | 13.78" | 11-9/16" | 8160 |
| Double Coil | 8268062 | | 10" | 7020 |
| Journal Spring | | | | |
| Inner Coil | 8268061 | 13-3/16" | 10" | 2410 |
| Outer Coil | 8268058 | 12-7/8" | 10" | 4610 |
| Double Coil | 8296131 | | 11-1/2" | 7690 |
| Journal Spring | | | | |
| Inner Coil | 8296130 | 14.20" | 11-1/2" | 2570 |
| Outer Coil | 8293170 | 14.25" | 11-1/2" | 5120 |
| Double Coil | 8308783 | | 11-1/4" | 7424 |
| Journal Spring | | | | |
| Inner Coil | 8250524 | 13.65" | 11-1/4" | 1164 |
| Outer Coil | 8232617 | 14.25" | 11-1/4" | 6260 |
| Double Coil | 8356313 | | 12" | 8425 |
| Journal Spring | | | | |
| Inner Coil | 8356312 | 14-7/16" | 12" | 2485 |
| Outer Coil | 8285950 | 14-7/16" | 12" | 5940 |
| Double Coil | 8390890 | | 11-7/8" | 10090 |
| Journal Spring | | | | |
| Inner Coil | 8390889 | 14.55" | 11-7/8" | 3120 |
| Outer Coil | 8390888 | 14.73" | 11-7/8" | 6970 |
| BOLSTER SPRINGS | | | | |
| Double Coil | 8232623 | | 18-1/2" | 27050 |
| Bolster Spring | | | | |
| Inner Coil | 8232618 | 22.22" | 18-1/2" | 8850 |
| Outer Coil | 8232620 | 22.40" | 18-1/2" | 18200 |
| Triple Coil | 8232624 | | 18-1/2" | 30975 |
| Bolster Spring | | | | |
| Inner Coil | 8232619 | 21.94" | 18-1/2" | 3925 |
| Intermediate Coil | 8232618 | 22.22" | 18-1/2" | 8850 |
| Outer Coil | 8232620 | 22.40" | 18-1/2" | 18200 |
| Triple Coil | 8252392 | | 19" | 41750 |
| Bolster Spring | | | | |
| Inner Coil | 8252391 | 22.70" | 19" | 3320 |
| Intermediate Coil | 8252390 | 22.23" | 19" | 11900 |
| Outer Coil | 8252389 | 22.52" | 19" | 26700 |
| Double Coil | 8261330 | | 17-7/8" | 14125 |
| Bolster Spring | | | | |
| Inner Coil | 8261329 | 20.69" | 17-7/8" | 2125 |
| Outer Coil | 8236351 | 21.00" | 17-7/8" | 12000 |
| Double Coil | 8293588 | | 15" | 9350 |
| Bolster Spring | | | | |
| Inner Coil | 8293587 | 18.87" | 15" | 2050 |
| Outer Coil | 8293586 | 18.30" | 15" | 7300 |

| | | | | |
|---------------------------------|---------|--------|---------|-------|
| Single Coil Bolster Spring | 8285949 | 20.75" | 17-1/4" | 10440 |
| Single Coil Bolster Spring | 8293586 | 18.30" | 15" | 7300 |
| Single Coil Bolster Spring * | 8374373 | 18.50" | 15-1/4" | 12400 |

ROUTINE MAINTENANCE PARTS AND EQUIPMENT

| | Part No. |
|--|----------|
| Four Wheel-Two Motor Truck Assemblies | |
| Center Bearing Half Ring | 8176177 |
| Center Bearing Wear Plate | 8321934 |
| Six Wheel-Two Motor Truck Assemblies | |
| Center Bearing Half Ring | 8176177 |
| Center Bearing Wear Plate | 8135935 |
| Six Wheel-Three Motor Truck Assemblies | |
| Center Bearing Half Ring | 8253870 |
| Center Bearing Wear Plate | 8135935 |
| Carbody Center Plate Bushings | |

| | Part No. Field Replacement Bushing | Part No. Original Bushing |
|---|---|---------------------------------|
| Four Wheel Trucks With 13" Diameter Center Bearing (Early G8 & G12) | 8262148 | 8191304 |
| Four Wheel Trucks With 18" Diameter Center Bearing | 8171333 | 8025351 |
| Six Wheel Trucks With 18" Diameter Center Bearing | 8262147 | 8252415 |

On current model locomotives, the carbody center plates are machined on the outside diameter and bottom surface and bushings or wear plates are not used.

| | |
|--|----------|
| Pinion Protector | 8206970 |
| Snubber Compression Fixture | File 650 |
| Tram Marking Tool | File 615 |
| Spring Testing Machine | File 647 |
| Pedestal Liner Pressing Tool | File 649 |

NOTE: File Drawings can be obtained by contacting Electro-Motive Service Department, La Grange, Illinois.