

C.M.I. 3954-5

**CLYDE  
MAINTENANCE  
INSTRUCTION**

**TRACTION MOTOR OVERHAUL**

May 1993

Clyde Engineering  
Motive Power Division  
1 Factory Street  
Granville, NSW, 2142  
Phone: (02) 6378288  
Fax: (02) 8972174

**SECTION 5  
ARMATURE INSPECTION AND  
RECONDITIONING**

**NOTE**

---

This D43 Traction Motor overhaul instruction is presented in seven sections, each under separate cover, and contains detailed instructions to completely disassemble, inspect, overhaul, assemble, and test the traction motor.

Refer to Maintenance Instruction, CMI 3901, for general or "running" maintenance of the traction motor and also for procedures to remove the traction motor from the locomotive bogie.

<u>Section No.</u>	<u>Title</u>
1	Disassembly
2	Bearing Component Inspection
3	Stator Inspection and Reconditioning - Mechanical
4	Stator Inspection and Reconditioning - Electrical
5	<b>Armature Inspection and Reconditioning</b>
6	Armature Overhaul
7	Motor Assembly

# **ARMATURE INSPECTION AND RECONDITIONING**

## **INTRODUCTION**

This section provides procedures for mechanical and electrical inspection and reconditioning of traction motor armatures.

## **ARMATURE CLEANING**

Prior to making any inspections, the armature should be thoroughly cleaned to remove all dirt, oil, and grease. The armature may be cleaned by blowing off all loose dirt and carbon dust, from the inside and outside of the armature using high volume, low pressure, dry air. In cases where air or dry wiping cloths can not remove caked dirt or grease, a brush or soft wood or fibre scrapers may be used. In severe cases it may be necessary to dampen a cloth in solvent, such as Shellsol 1626 Solvent, to loosen and remove imbedded deposits.

### **CAUTION!**

Ensure there is adequate ventilation and safety precautions are observed when handling inflammable fluids such as Shellsol 1626 Solvent

Clean ventilation holes in armature core. Minimum diameter of holes is 23.8 mm.

If a solvent has been used to clean the armature, blow off as much of the solvent as possible using high volume, low pressure, dry air. Let the armature stand until remaining solvent has evaporated and the armature is completely dry before making any electrical tests. Mechanical inspection may be performed during the period when armature is drying.

## **INSULATION RESISTANCE TEST**

Before any work is performed on the armature, the armature should be given an insulation resistance test using a 500 volt DC megohmmeter. The armature shall have a minimum insulation resistance of 3 megohms.

If the armature fails to meet the minimum resistance reading, place the armature in an oven for 6 hours at 110° C (230° F). Recheck armature insulation resistance after armature has cooled to room temperature. If the readings are still low, the armature must be checked to determine the cause.

Perform the following sequence. Megger between each step.

1. Remove string band from commutator end.
2. Remove pinion end bands.
3. Remove pinion end bell.
4. Remove commutator end band.

If megger reading is still below tolerance, the armature must be rewound. Refer to Section 6, Armature Overhaul.

When megger readings are to the specified limits, perform a high frequency or surge test on the armature winding insulation.

## **HIGH FREQUENCY OR SURGE TEST**

NOTE: The purpose of this test is to stress the insulation of the armature in a manner similar to actual operation of the motor. The insulation between turns, the insulation be-

tween layers of windings, and the insulation between the windings and the core should be simultaneously subjected to voltage (potential) stress.

A high frequency test can be performed which induces voltage to the armature coils electromagnetically. Because the armature winding is the equivalent of an inductance coil, this can be accomplished by impressing a high frequency voltage on the armature coils. Test the armature at 1800 volts. If a variation between high and low reading occurs that is greater than 1070, the armature is not acceptable. The minimum acceptable reading is 50 volts.

A surge test can be performed comparing voltage waveforms using a suitable surge tester.

If armature fails on high frequency or surge test and the failure is located in an upper coil, the upper coil can be raised and repaired, providing condition of the armature warrants this type of repair.

If armature passes the high frequency or surge test, perform a commutator bar-to-bar resistance test.

### **COMMUTATOR BAR-TO-BAR RESISTANCE TEST**

The commutator bar-to-bar resistance test is made with a low resistance ohmmeter which measures resistance in micro-ohms. Refer to EMD Service Tools catalogue for ohmmeter part number.

The ohmmeter may be set for reading the scale direct or in multiples of from 10 to 10,000. With the ohmmeter range switch set at X 10, the resistance indication between adjacent commutator bars should be 70-72 micro-ohms at an ambient temperature of 21°C (70°F), but variations in temperature and test equipment can result in indications as low as 60-62 micro-ohms. However all bar-to-bar resistance indications on individual

armature should be the same. Maximum allowable limits should be plus or minus 1 point on the scale from the established normal indication. Normal indications of the armature is established by taking resistance readings on approximately 20 bars. The indication most consistent can be considered the normal reading.

Very high resistance or open circuits in the armature will cause the overload protector in the ohmmeter to open. Press RESET button to put ohmmeter back into operation.

The commutator riser should not be disturbed before performing the bar-to-bar resistance test. Removing paint with a file or a light lathe cut may temporarily correct any high resistance problem by copper drag-over between the coil leads and the riser. If this should occur, the ohmmeter would not show a high resistance indication. In such case, the real trouble, for example a poor solder connection, would show up in operation.

Perform bar-to-bar resistance test as follows:

1. Turn on ohmmeter and allow at least 20 second warmup.

**NOTE:** Ensure undercut slots between commutator bars are clean and free of any copper chips before performing, test.

2. Set ohmmeter range switch to X 10. Ensure ohmmeter is in a level position.
3. Each test prod of the ohmmeter has two needle points. Red is the potential needle and black is the current needle. The prods must be placed so that the red needles are towards the center of the commutator, Fig. 1.

## **SERVICE DATA**

---

### **SPECIFICATIONS**

#### **COMMUTATOR WEAR LIMITS**

Minimum Diameter .....	405mm
Mica Groove Depth .....	1-2mm
Mica Width - D43.....	1.27mm
Minimum Riser Neck Width .....	16mm
Minimum Riser Neck Diameter .....	465mm

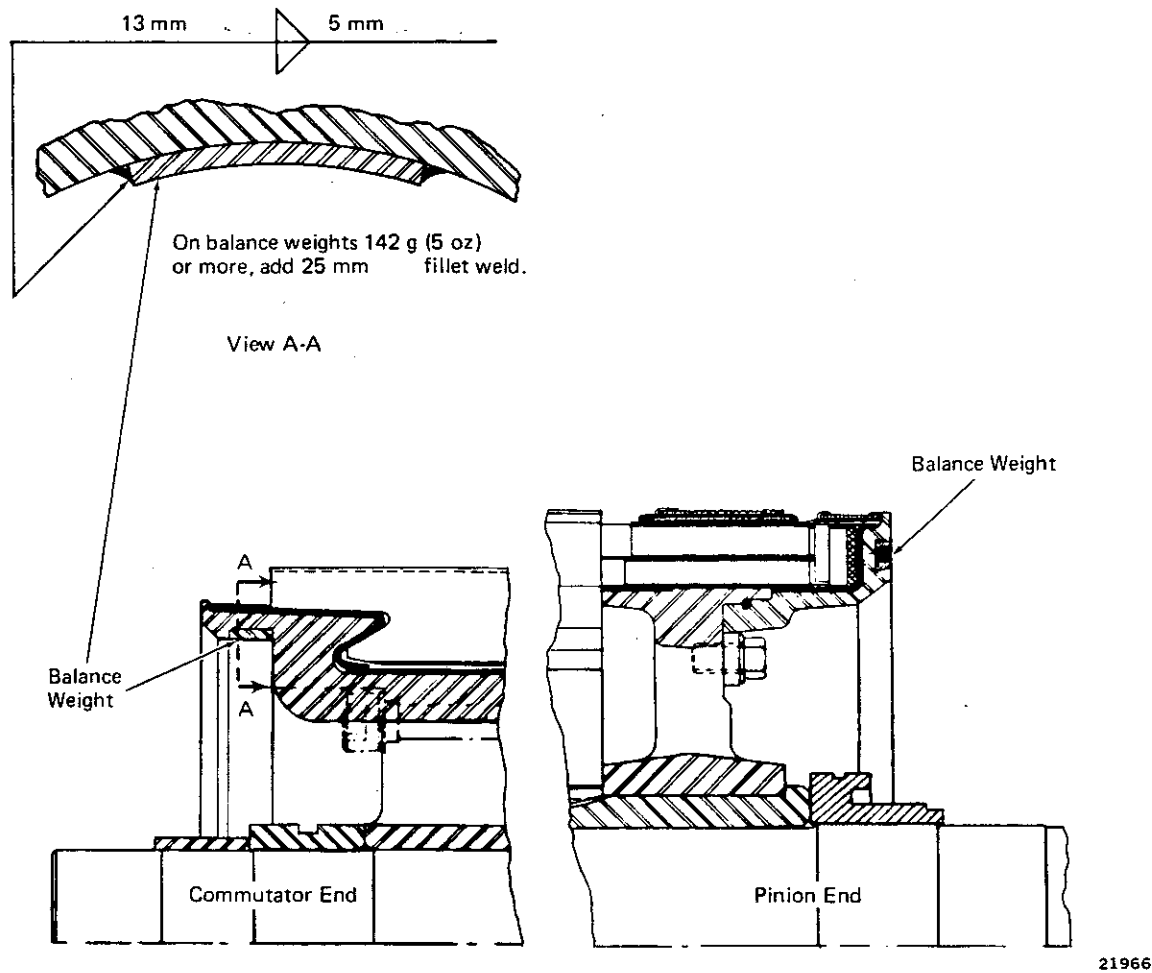

Fig. 16 - Balance Weight Placement

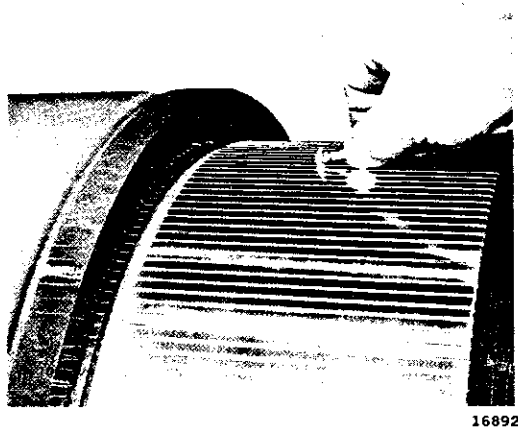

Fig. 17 - Removing Burrs from Commutator Bars

**NOTE:** The 3mm deep relief at the base of the commutator riser is acceptable at 1.6mm.

6. Perform a final bar-to-bar resistance test. Refer to Commutator Bar-to-bar Resistance Test portion of this section.

### ARMATURE PAINTING

Paint the pinion end coil support and end bell, and commutator spider with red air drying enamel. Do not paint over core section or bands.

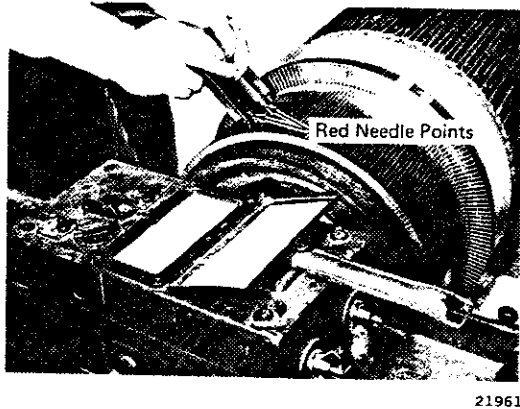

Fig. 1 - Bar-to-Bar Resistance Check

4. Apply prods on adjacent commutator bars with enough pressure to penetrate surface of the copper. When moving to the next bar, move one prod at a time to adjacent bar, breaking contact with the black needle then the red needle.
5. Establish a "normal" indication by checking approximately 20 bars.
6. Check every bar in the commutator, allowing one point above and below as a maximum over the established normal indication. Mark the commutator bar edge to indicate any high or low indication for later correction.

Indications above normal indicate high resistance due to defective circuits, usually caused by poor solder joints in the commutator riser.

**NOTE:** When making a bar-to-bar check of the commutator, it is possible to determine if the problem is in the equalizer circuit (commutator bar cross connectors connect bars 180° apart, bar 1 is connected to bar 106, etc.) or main winding circuit. Example of main winding problem: bar-to-bar indications on the first 90° of the commutator are 64-66 micro-ohms (range switch set to X 10), which may be considered the normal indications. Continuing indications of 73-75 micro-ohms are found. This variation is greater than the plus or minus 1 point on the

ohmmeter scale and indicates a high resistance connection. Because of the equalizer circuit either identical, higher, or slightly lower indications will be found 180° from the previous high indications. In this case, the 180° indications are 69-70 micro-ohms. To correct, repair the leads where the high indications occurred. When these leads are repaired, the 180° indications will also be corrected.

This example would indicate that the problem was in the main winding circuit and not in the equalizer circuit because the indications were not the same 180° apart, however, the equalizer circuit provides a parallel path between windings 180° apart and will reflect the high indication on the opposite side of the commutator.

Example of equalizer circuit problem: normal indications around commutator are 64-66 micro-ohms and high indications are experienced 180° apart. It can be assumed the problem is in the equalizer circuit. Higher than normal indications 180° apart indicates problem in the equalizer circuit.

It is not possible to determine which side of the equalizer circuit has the problem. Repair the leads on one side of the equalizer circuit and if problem remains, repair the other side.

If after reworking both sides of the equalizer circuit, problem still exists, the equalizer circuit is either oxidized to the point where solder will not adhere, or the equalizer is out of the circuit. To verify this condition, place one test prod on a commutator bar with high indications, bar 1; place the other test prod on bar 106. With the range switch set to X 100, the normal indication should be approximately 13 micro-ohms. If the ohmmeter indicates 20 micro-ohms, or higher, the equalizer is definitely out of the circuit, and the armature must be rewound. It is possible to have a motor operating with improper contact on equalizer leads, but it is

not recommended, as a failure may result with considerable damage to the commutator.

7. When correcting suspected connections, hand solder with pure tin solder. If a large number of leads show high readings, the complete commutator riser should be resoldered. If after soldering, a bar-to-bar resistance check still shows high indications, the riser should be split at the lead connection and the leads fluxed and set. Solder the riser again, if test results are still unsatisfactory, the armature should be stripped and rewound. Unsatisfactory indications after the second soldering usually indicates cracked armature coil straps. Refer to Section 6, Armature Overhaul, for rewinding procedure.

### ARMATURE INSULATION RESISTANCE

Check armature insulation resistance. Measure cold temperature with thermocouple probe and potentiometer on commutator.

The armature insulation resistance at 75<sup>o</sup> C (167<sup>o</sup> F) shall be 0.0105 ohms +/- 2%.

### MAGNETIC PARTICLE INSPECTION

A magnetic particle inspection should be performed to qualify the shaft for re-use before dimensional checks are made. Ensure the shaft is clean and free of all rust and oil.

The shaft must be magnetized to perform a magnetic particle inspection, but the shaft may retain enough residual magnetism to check. Check the shaft for residual magnetism by one of the following two methods:

1. Apply magnetic powder to the end of shaft. The powder should adhere. If it does not adhere, it will be necessary to magnetize the shaft.
2. Suspend a short length of iron or steel wire at the end of a piece of string near the end of the shaft. Observe any attraction of the wire to the shaft. If no attraction is observed, it will be necessary to magnetize the shaft.

**NOTE:** If there is any doubt as to the shaft being sufficiently magnetized, the shaft should be magnetized.

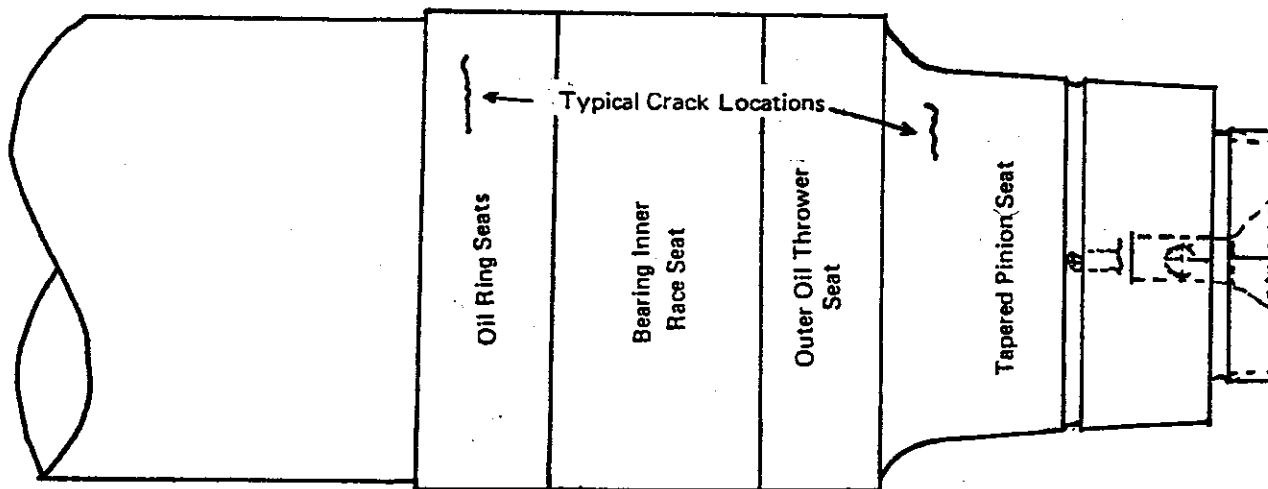

Fig. 2 - Circumferential Shaft Defects

The shaft can be magnetized by using a unit capable of producing 500 to 700 amperes of alternating current and wrapping three turns of No. 0000 flexible cable around the ends of the shaft.

Apply current to the cable turns to magnetize the shaft.

After it is determined that shaft is magnetized, apply magnetic powder sparingly to the tapered pinion seat and adjacent machined surfaces, refer to Fig. 2. Any circumferential cracks or defects are causes for rejection. These cracks usually occur at the pinion end especially on the tapered area.

**NOTE:** Service history has indicated that small longitudinal cracks have little effect on service life of the shaft, therefore this Maintenance Instruction does not include inspection for cracks in that direction. Any longitudinal marks on the shaft that have raised edges should have the raised edges blended in with the shaft to allow proper fit of parts that will be assembled to the shaft.

### DIMENSIONAL INSPECTION

1. Inspect the commutator end bearing seat diameter, Fig. 3. Bearing seat diameter of a new shaft is 75.02 mm.

Minimum rebuild tolerance is 74.82mm.

2. Inspect the combined commutator end spacer and collar outside diameters, Fig. 3. Outside diameter of the spacer should be between 104.77 to 104.64 mm. Outside diameter of the collar should be between 140.84 mm to 140.71 mm.
3. If spacer or collar are not within specified limits, replace with a new spacer or collar.
4. Check the dimension from the commutator end collar face to the end of the shaft, Fig. 3. The dimension should be

between 43.45 mm to 43.07 mm. This dimension is required to ensure free movement of the bearing parts and a tight fit of the bearing race on the shaft.

5. Inspect the threads of the bolt holes on the commutator end of the shaft, Fig. 4. If threads are nicked or slightly damaged, retap holes. The threads must be class 1B. If threads are severely damaged or beyond thread pitch diameter limits, replace shaft with a new shaft.
6. Inspect the threads on the pinion end of the shaft, Fig. 5. If the threads are nicked or slightly damaged, rework threads with armature shaft die. Refer to Service Data for die and die holder part number. Check thread pitch diameter. Acceptable thread pitch diameter is 67.513 mm to 67.915 mm. If threads are severely damaged or beyond thread pitch diameter limits, replace shaft with a new shaft.

**NOTE:** When armature shaft bearing diameters are worn beyond acceptable limits, the diameters may be built up by plating. Plated shafts should be identified with a 5 mm letter P stamped adjacent to the armature serial number.

7. Inspect pinion end inner oil ring for roughness and wear, Fig. 5. Maximum runout of the oil ring is 0.05 mm total indicator reading.
8. Check pinion end shaft diameters for size as shown in Fig. 5.
9. Inspect bearing and pinion seat surface for damage, fretting, corrosion, or roughness. The pinion seat may be cleaned by rubbing lightly with crocus cloth. Do not rub the pinion seat axially or work below the normal surface. Do not use shaft with heavy damage to the pinion seat.

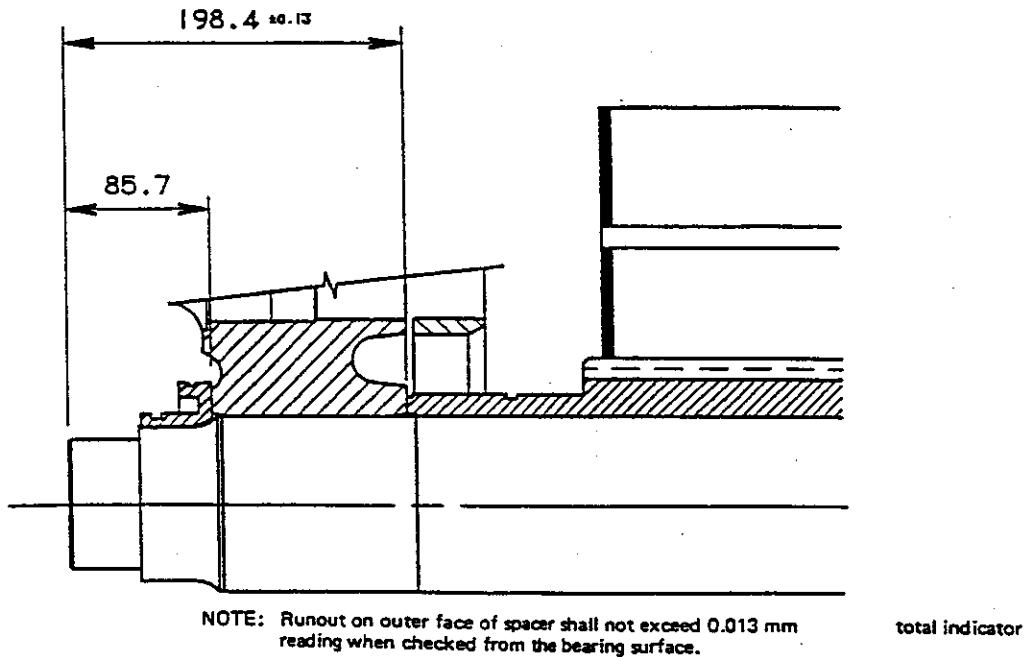

21963

Fig. 13 - Commutator End Spacer and Collar Assembly

Check commutator taper. Commutator taper shall not exceed 0.13 mm maximum.

**COMMUTATOR UNDERCUTTING**

1. Check the depth of the slots between the commutator bars. Slots should be between 1-2 mm deep. If slot depth is not within tolerance, commutator mica will have to be undercut.
2. Check width of mica between bars, Fig. 14.
3. Undercut commutator mica using undercutting tool similar to Fig. 15, if required. After undercutting, blow off any loose copper and mica using low pressure, high volume, dry air. Do not blow copper dust toward armature windings.

**DYNAMIC BALANCE**

The armature should be dynamically balanced at 500 RPM to within 1440 mg m (2 in.-oz.). Armature must also be checked when "floated" through "critical speed". Refer to Service Data for balance weights and set screw part numbers.

On the pinion end of the armature, apply balance weights into the groove of the end bell, Fig. 16, and lock in place with a set screw. Stake weights at end bell to prevent shifting.

On the commutator end of the armature, apply balance weights under the commutator "V" ring, Fig. 16. Weld in place.

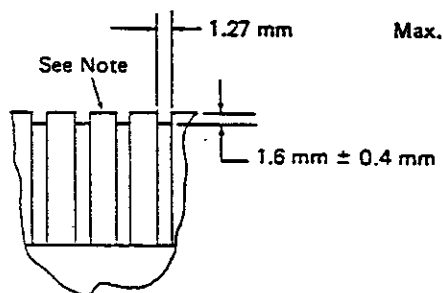

NOTE: Excess copper and mica to be removed from sides of the bar and slot.

21964

Fig. 14 - Commutator Bar Mica Limits

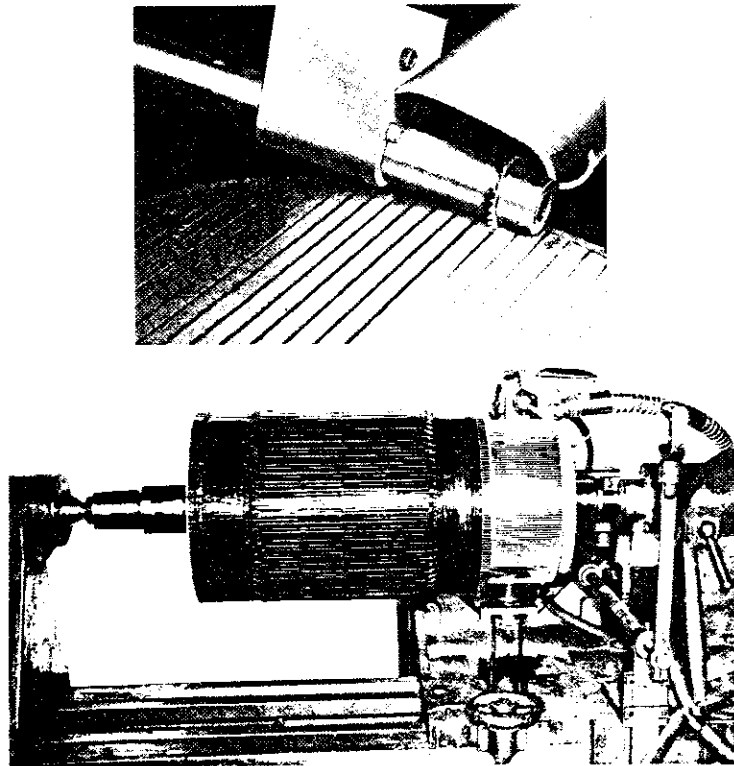

21965

Fig. 15 - Apparatus for Undercutting Mica

**CAUTION:**

Do not apply excessive heat to "V" ring when welding balance weights, as heat may damage string band or distort steel "V" ring.

**DE-BURRING COMMUTATOR**

1. Place armature in a lathe and grind and polish the commutator. Grind the commutator as required using a fine grit stone. Refer to Service Data for stone part number. Ensure grinding operation does not exceed the commutator diameter limits. Refer to Service Data for commutator limits.
2. Check commutator taper. Taper shall not exceed 0.13 mm, maximum.
3. Break the edges of commutator bars using a de-burring tool as shown in Fig. 17. Refer to Service Data for commutator bar de-burring tool.
4. Blow off commutator using low pressure, high volume dry air. Do not blow copper dust towards the armature windings.
5. Remove any remaining dirt, varnish, and red air drying enamel on the mica segments between commutator bars, on the riser face, and in the recess until mica is clean. Hand tools such as scrapers and hacksaw blades may be used. Remove any copper bridging over mica segments on riser face. Minimum space between bars to be 0.8mm in TIG welded area. Brush out any copper dust or particles that may accumulate.

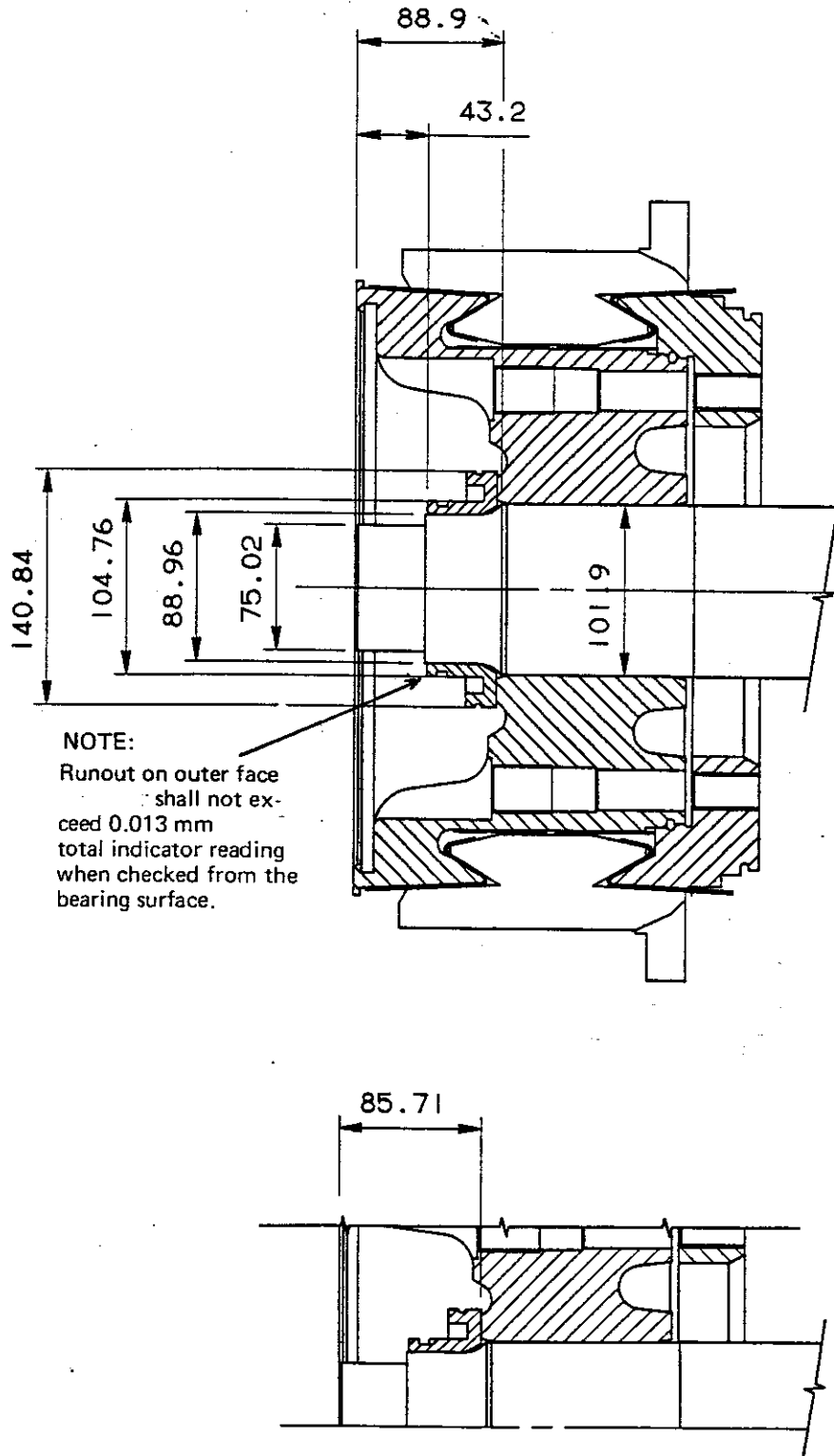

Fig. 3 - Armature Shaft - Commutator End

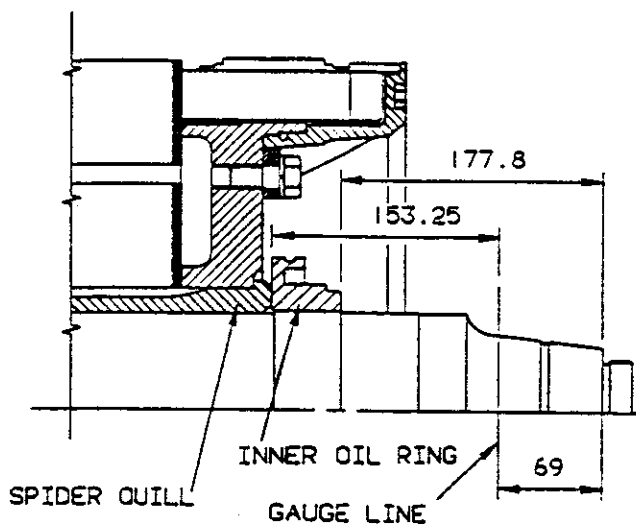

Fig. 12 - Pinion End Inner Oil Ring Assembly

1. If dimension is undersize, machine spider or spider quill as necessary to obtain proper dimension. Do not machine end of shaft.

If dimension is oversize, add laminated spacers. Each spacer is 0.8 mm thick and constructed of layers of 0.08 mm laminations. The laminations can be removed as required to obtain the proper amount of thickness. Check spacer size with a micrometer before applying to the shaft.

2. Heat pinion end inner oil seal and commutator end collar and spacer by suspending in SAE 50 oil (with a safe flash point) at a temperature of 115°-125° C (240°-260° F). The oil container should have a false perforated bottom which will prevent direct transmission of heat from the heating unit to the parts. Ensure oil and container are clean.
3. After heating, remove pinion end inner oil seal from oil bath. Remove oil from seal with clean bound-edge cloths. Shrink the inner oil ring to the shaft and

allow to cool to room temperature, Fig. 12.

4. Check the commutator end dimension from the end of the shaft to the commutator spider, Fig. 13.

If the dimension is undersize, machine spider as necessary to obtain proper dimension. Do not machine the end of the shaft.

If the dimension is oversize, add spacers.

Each spacer is 0.38 mm thick. Add spacers as required to obtain the proper amount of thickness.

5. After heating, remove commutator end collar and spacer from oil bath. Remove oil from collar and spacer with clean, bound-edge cloths. Shrink collar and spacer to the shaft and allow to cool to room temperature, Fig. 13.
6. Place armature in a lathe and check runout of the shaft.

Maximum runout of pinion end bearing seat is not to exceed 0.05 mm total indicator reading.

Maximum runout of pinion end oil ring face is not to exceed 0.05 mm; total indicator reading.

Check and machine the distance between the commutator end spacer and end of shaft as shown in Fig. 13. Use care not to cut into shaft as spacer is machined.

Indicate commutator end spacer face. Total runout not to exceed 0.013 mm total indicator reading.

7. Check and machine, if required, the commutator brush surface and riser to obtain a good surface. Refer to Service Data for commutator limits.

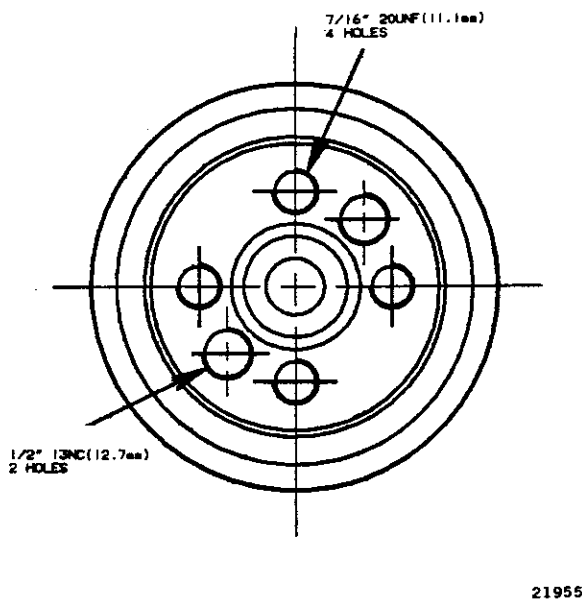

Fig. 4 - Commutator End Shaft Bolt Holes

**NOTE:** Pinion taper may be reground to remove light scoring, fretting, or roughness, provided that the pinion advance does not increase more than 0.38 mm .

## **MECHANICAL INSPECTION AND REPAIR**

### **END BELL**

Inspect end bell for tightness. Tighten eight 5/8"-11 bolts as required.

Check end bell by tapping lightly with a small mallet. If the end bell is loose, a white powder will be visible around partings as bell is tapped. If powder is visible, the end bell should be removed and the insulation renewed, Fig. 6. Refer to Armature Overhaul, Section 6, of this Maintenance Instruction for installation and insulation of end bell.

### **PINION END COIL SUPPORT**

Inspect pinion end coil support, Fig. 6, for cracks. When cracks are found, coil support must be replaced with a new coil support.

## **COIL STRAP INSPECTION**

Inspect coil straps. If broken coil straps, or indication of excessive movement of the windings is found, armature must be re-wound. When broken coil straps are found, the armature shaft must be removed. Refer to Section 6, Armature Overhaul for procedure.

## **SLOT WEDGES**

Inspect armature slot wedges. Slot wedges must not be loose or charred. Check slot wedges for loose condition by placing fingers on a wedge and tapping the wedge lightly with a small mallet. Check each wedge in this manner. Charred or loose wedges must be replaced. Refer to Fig. 7.

If there is only slight evidence of loose slot wedges, the armature, should be vacuum impregnated with varnish. Refer to Varnish Treatment portion of this section.

If it is determined that slot wedges must be replaced, refer to Armature Overhaul, Section 6, for procedure.

## **COMMUTATOR END STRING BAND**

All varnished or painted polyester string bands or epoxy coated string bands which require replacement should be replaced with fiberglass cord string band and teflon string band covering.

If the string band is being replaced with a fiberglass cord string band or if a new fiberglass cord string band is required, refer to Fig. 8 and perform the following procedure:

1. Remove any loose cement from commutator "V" ring.

6. With vacuum still on tank, run varnish into tank to minimum level of 8 mm over rear side of the commutator riser outside diameter to a maximum of up to, but not over, the riser face. If varnish should flow over riser face, wipe riser face clean with Xylol. Break down foam by occasionally injecting small amounts of CO<sub>2</sub> into impregnating tank as varnish rises around armature. If vacuum is not sufficient to draw varnish up to the required level, CO<sub>2</sub> may be injected into the tank to force the varnish up to the desired level. Do not open release valve to admit atmospheric air into impregnating tank.
7. Reduce vacuum to zero with CO<sub>2</sub> additions. Check that varnish is at the proper level, then increase CO<sub>2</sub> pressure to 200-275 kPa. Allow armature to remain under pressure for a minimum of 15 minutes to a maximum of 20 minutes.
8. Reduce CO<sub>2</sub> pressure to 70-100 kPa by opening vacuum valve. Do not open release valve to atmospheric air. Empty varnish from impregnating tank using the 70-100 kPa CO<sub>2</sub> pressure.
9. Open release valve to atmospheric air. Allow armature to drain for 25 minutes. Upon completion of drain period, close release valve and apply 710-760 mm vacuum for a minimum of 5 minutes.
10. Remove armature from impregnation tank and wash varnish from shaft, end bell, and commutator face and risers with a rag saturated with Xylol or petroleum solvent. On armatures with hydraulic pinion removal feature, thoroughly clean hydraulic hole passages with solvent, then re-apply 1/2"-20 set screw finger tight.
11. Place armature in a convection oven.

**NOTE:** Bake cycle should start within 15 minutes after completion of impregnation cycle.

12. Attach thermocouple to armature commutator. Bake armature 6 hours after average core temperature reaches 155° C (311° F). Ensure commutator temperature does not exceed 155° C or oven temperature does not exceed 175° C (347° F).
13. Remove armature from oven and while armature is still between 40°-60° C (104°-140° F), perform a ground test at 3200 volts for 1 minute. If armature fails ground test, armature will have to be rewound. Refer to Section 6, Armature Overhaul for rewinding procedure.
14. If commutator bolts have been loosened for any reason during repair, torque commutator bolts as follows:

Commutator with Nomex "V" rings -  
373 Nm (275 ft lbs)

**NOTE:** Before torquing commutator bolts, break the tack weld by rotating the bolt counterclockwise. Every other bolt may be removed and the weld removed from bolt head. Replace the four bolts with hardened washers and torque before disturbing the remaining bolts.

15. Tack weld commutator bolts after torquing.

#### **FINAL ASSEMBLY OF ARMATURE**

1. Check the pinion end dimension from the end of the shaft to the armature spider quill, Fig. 12.

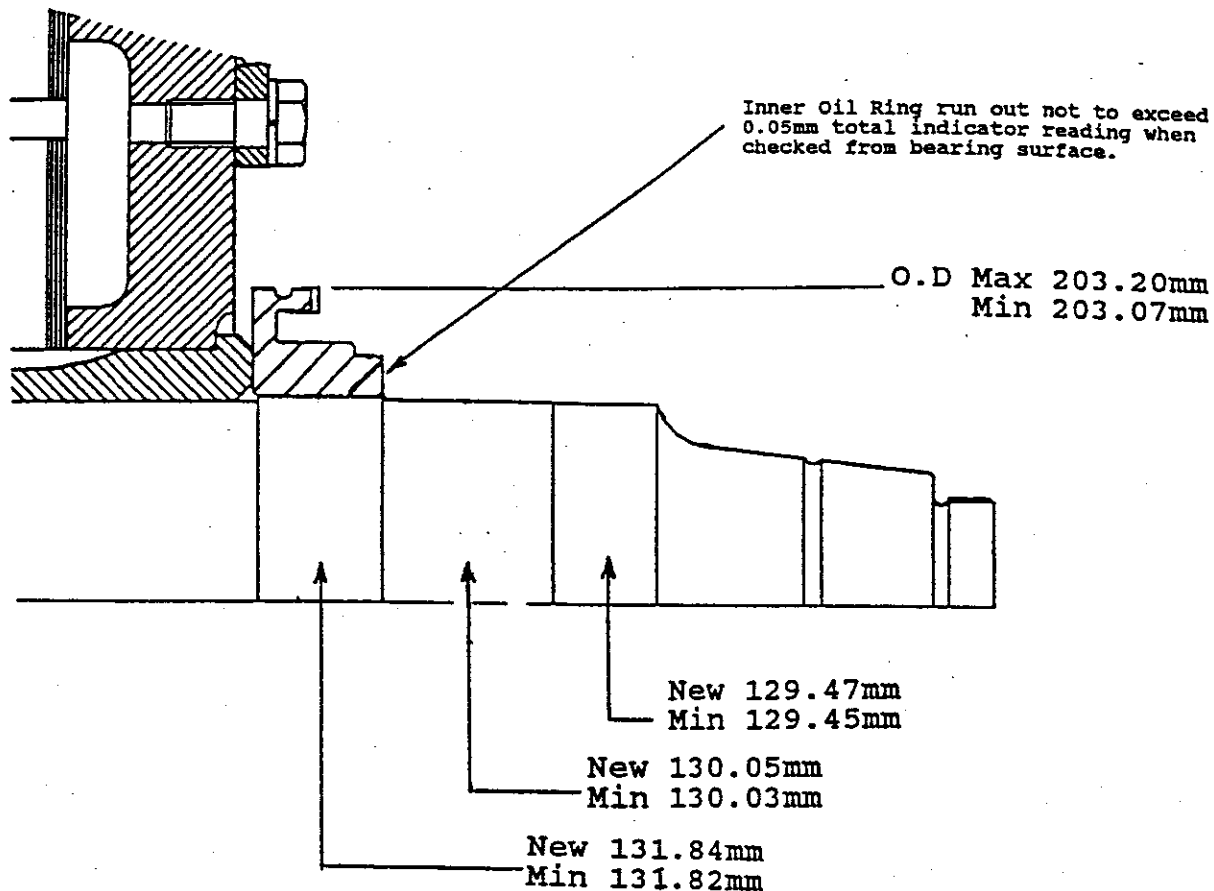

Fig. 5 - Armature Shaft - Pinion End

2. Mix epoxy resin kit per instructions furnished with the kit. Refer to Service Data for kit part number.

**NOTE:** Epoxy resin and catalyst also available in bulk quantities and can be mixed in the proportion of 950 cc of polyester resin to 10 cc of catalyst. These recommended proportions result in a mixture "pot life" of approximately nine days. Refer to Service Data for part numbers of polyester resin and catalyst.

3. Apply a liberal coating of epoxy resin with a 25 mm brush to the commutator "V" ring. Do not allow the epoxy resin to work into the slots of the commutator.

4. Wind in one layer of glass cord over epoxy resin coating. Starting next to the commutator, secure one end of cord by overlapping one turn as shown in Fig. 9. Keep glass cord pulled tightly and keep turns as close together as possible. When there are approximately four turns left to make, form a loop of a short piece of the cord and wind under the remaining turns, leaving the loop and loose ends exposed as shown in Fig. 10.
5. When all turns are completed, cut cord from spool and insert loose end through formed loop and carefully pull loose end under, but not out of, the turns. Cut all loose ends flush with the layer of glass cord. Apply a liberal coat of epoxy resin over the glass cord.

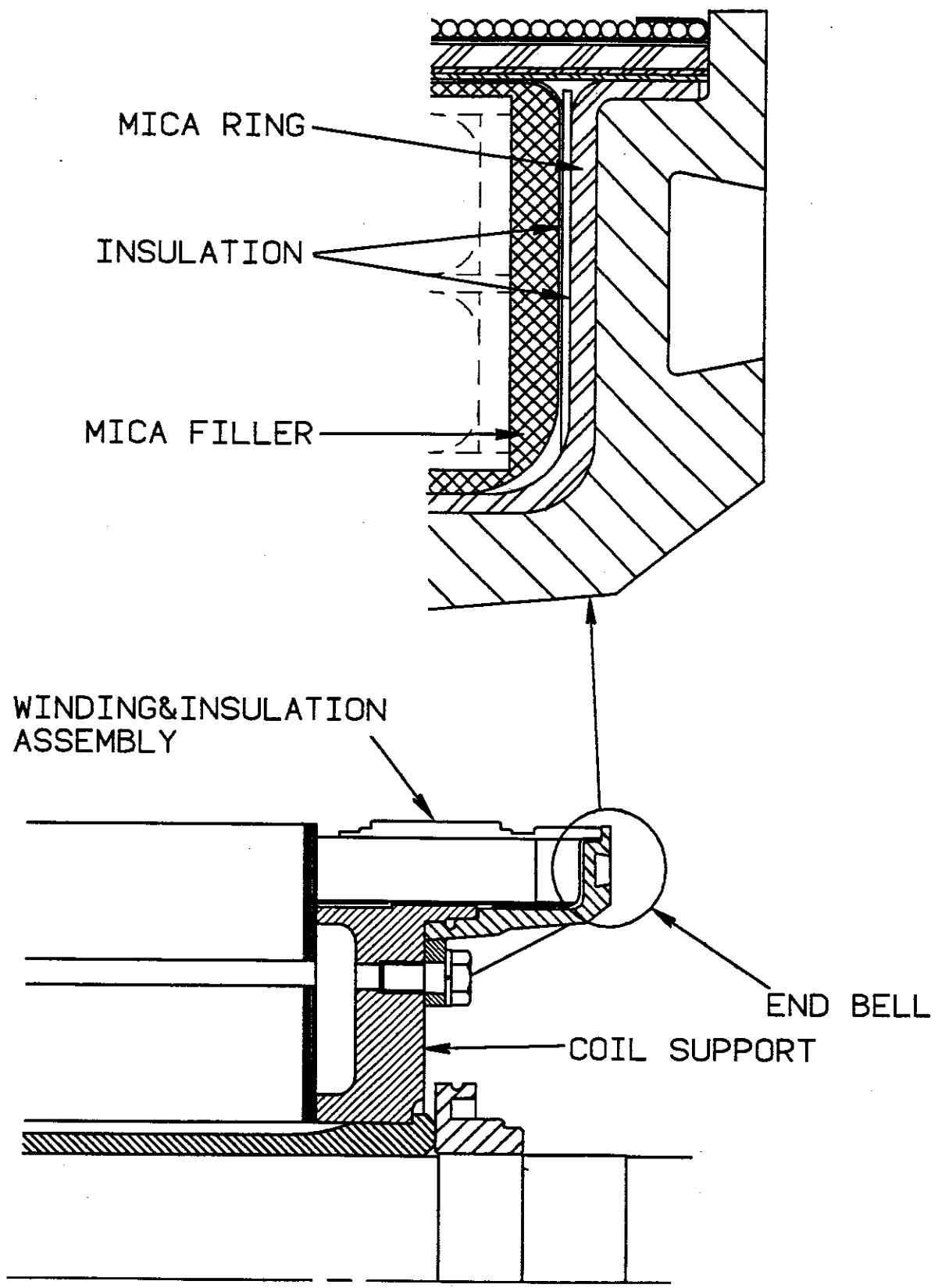

Fig. 6 - Armature End Bell Assembly

7. After varnish treatment is completed and armature has cooled to room temperature, remove the layer of fibre-glass tape and check for possible damage to silicone compound.

### INSULATION INSPECTION

Inspect armature insulation for evidence of powdering. If very slight evidence of powdering is found, it will generally be accompanied by loose wedges or tension bands. This can be reworked by rebanding, rewedging, and varnish impregnating the armature. Refer to Slot Wedge, Tension Bands, and Varnish Treatment portions of this section for reworking armature.

If evidence of heavy powdering is found, the armature must be rewound. Refer to Armature Overhaul, Section 6, of this Maintenance Instruction.

Inspect for charred or dry insulation. If insulation is charred, the armature should be rewound. If insulation is dry, the armature should be varnish impregnated.

If the armature core is scuffed or rubbed on the outside diameter, the damage is acceptable over any portion of the core outside diameter providing the damaged area, after cleanup (lamination edges must be clearly visible), has not been reduced more than 0.46 mm.

### COMMUTATOR INSPECTION

Inspect the commutator on the armature assembly as follows:

1. Inspect commutator surfaces for stand-still burns, damaged bars, high bars, raised mica, grooving, and powdered or loose mica segments. If the commutator brush surfaces and/or riser have been damaged, they should be machined in a lathe before making further checks.
2. Check the diameter of the commutator brush surface. Condemning limit is 405mm.  
  
If below this limit, the commutator must be replaced.  
  
Maximum taper of this surface shall not exceed 0.3 mm, providing the surface has not recently been machined or stoned, in that case, the maximum taper, should not exceed 0.13 mm. The allowable out-of-round should not exceed 0.03 mm, total indicator reading, when shaft is rotated between centers. Assembled as a motor, the runout should not exceed 0.05 mm on this surface.
3. Check commutator for surface irregularities. The overall minimum and maximum indications of the dial indicator obtained in Step 2 are not applicable as a measurement of commutator surface irregularity. Commutator surface irregularity is concerned with bar-to-bar movement. An example of this would be to have readings around the commutator that have a total variation of 0.05 mm however hidden within the 0.05 mm variation are six low areas, each spanning one or more bars. This commutator would cause the brushes to bounce with resultant damage.  
  
A commutator having a total variation of 0.10 mm with the minimum and maximum readings 180° apart is an acceptable commutator whereas the first example, 0.05 mm variation with several low areas, is not acceptable even though the total variation is much less.  
  
It is difficult to give a number value which would determine when a commutator should be ground. The values obtained by dial indicator must be evaluated with respect to performance of the generator (brush problems, flashovers, etc.) and a certain amount of

personal judgment must be used. A useful "rule of thumb" is that any condition worse than 0.05 mm in a six bar span calls for grinding the commutator.

4. Check the width of the riser (neck), which must be wide enough to provide sufficient stock so that after final commutator machining, the width shall not be less than 16 mm. If less than 16 mm, the commutator must be replaced.
5. Check the riser diameter. The minimum riser diameter is 465mm.

**NOTE:** The area behind the riser can not be checked on armatures that have epoxy resin applied to the commutator end wire band.

6. Inspect for damaged V-ring and string band. If string band is broken or burned through so the V-ring is damaged, the commutator insulation V-ring must be replaced.
7. Inspect commutator spider for cracks. If cracks are found, the spider must be replaced with a new spider. Refer to Armature Overhaul, Section 6, for procedure.
8. Check the dimension from the core side of the commutator bore to the outer face of the brush surface. The minimum acceptable dimension is 170mm if a 2 mm shim is used between the commutator and core at line up.
9. If commutator meets specifications and no machining is required on brush surface, clean out slots between commutator bars across brush surface. Remove all carbon dust, dirt, and foreign matter from the slots. Special care must be taken to cut below any oil soaked or burned mica patches. This can be accomplished with a hack saw blade or similar tool. Care must be exercised

not to scratch the brush surface of the commutator bars, or raise burrs on bar edges.

#### VARNISH TREATMENT

Armatures which have been repaired and inspected other than final machining of the commutator and armature balancing, should be vacuum impregnated with varnish. Varnish should be thinned to maintain Ford cup No. 4 orifice viscosity at 250-325 seconds at 21.1° C (70° F) and a minimum specific gravity of 0.900 Refer to Service Data for varnish and thinner information.

Perform vacuum impregnation of armature assembly as follows:

1. Clean armature core section thoroughly with Xylol or petroleum solvent and wipe dry with clean dry cloths. On armatures with hydraulic pinion removal feature, remove 1/2"-20 set screw in the shaft center prior to varnish impregnation.
2. Brush-coat armature core tooth and wedge area with baking varnish. Do not thin varnish.
3. Preheat armature in a convection oven so that the average armature core temperature stabilizes at 120° C + 5°, -10° C (248° F + 9°, - 18° F). Ensure core temperature does not exceed 125° C (257° F) or oven temperature does not exceed 175° C (347° F).
4. Remove armature from oven and place in vacuum impregnation tank. Average core temperature of armature should be between 100° C to 120° C (212°-248° F) when placed in tank. Do not allow armature core to cool below 100° C before placing in tank.
5. Apply 710-760 mm vacuum to tank for 15 minutes. Bolt down tank lid while vacuum is building up.

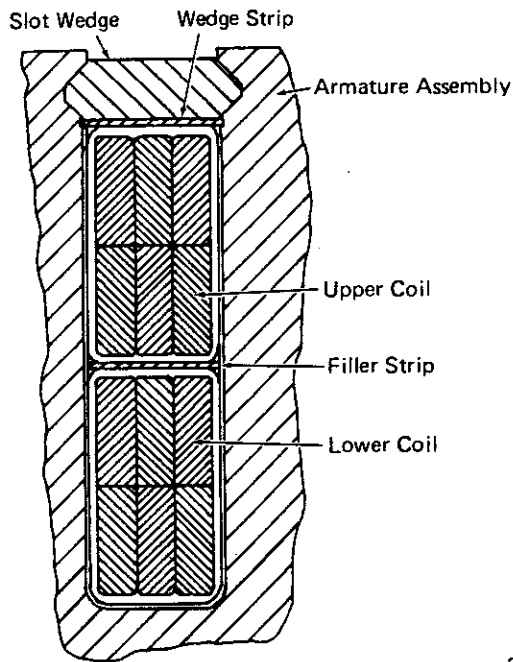

21958

Fig. 7 - Armature Coil Slot Assembly

Ensure the vertical edge of the commutator bars is clean and in good condition, refer to Fig. 8 and perform the following procedure to install the string band covering:

1. Apply epoxy primer to vertical edge of commutator. Refer to Service Data for epoxy primer part number.
2. Apply adhesive film to string band and commutator wall where string band covering will seat. Refer to Service Data for adhesive film part number.
3. Install the string band covering and apply pressure with a steel band or similar device. Ensure there is no more than an 8 mm gap between the string band covering outer edge and inner edge of the commutator spider assembly.
4. Place armature in an oven and bake at  $149^{\circ}\text{C}$  ( $300^{\circ}\text{F}$ ) for 1 hour.
5. Remove armature from oven and remove steel pressure band.

Polyester type string bands not requiring replacement, should be thoroughly cleaned. If pitting and arc burns are present, the string band should be sanded with sandpaper to remove imperfections and to remove the glossy surface. Apply a coat of epoxy resin as outlined previously.

String bands coated with epoxy resin must not be painted with red air drying enamel.

When the string band behind the commutator riser is removed, inspect the filler under the band. If the filler is loose, cracked, or thrown out, the filler must be replaced with new filler.

### TENSION BANDS

Inspect the wire or fiberglass tension bands to ensure bands are not loose or damaged. If the bands are cut, scuffed, cracked, or wire bands have thrown solder or are loose, and the rest of the armature is satisfactory, the bands should be replaced. Refer to Section 6 of this Maintenance Instruction for replacement procedure.

Current model traction motor armatures are banded with non-magnetic wire at the pinion end and banded with fiberglass tape at the commutator end, Fig. 11. Those units manufactured with wire bands at both the commutator end and pinion end should have the commutator end band replaced with fiberglass band when the band requires replacement. Refer to Section 6 of this Maintenance Instruction for replacement procedure.

On a unit with a satisfactory wire band on the commutator end, the wire band must have a covering of fiberglass tape and epoxy. Apply fiberglass tape and epoxy as follows:

1. Remove all paint and dirt from the commutator end wire band with a wire brush.

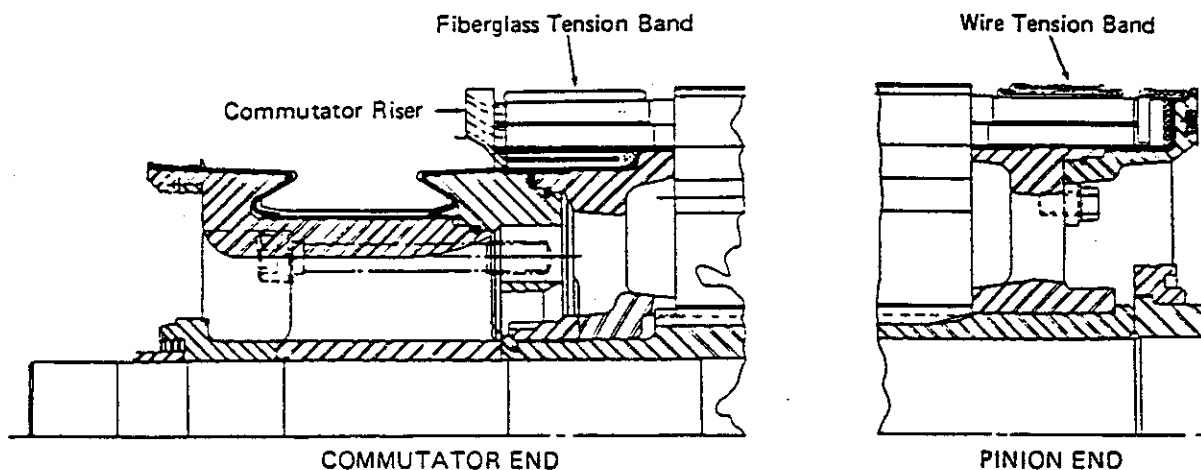

21960

Fig. 11 - Tension Band Assembly

2. Clean area to be repaired with a clean cloth moistened with alcohol. Do not over saturate the area.
3. When alcohol has evaporated, apply silicone compound to chafed areas of insulation or exposed copper straps. Spread silicone compound evenly with a putty knife or similar tool over chafed area. Spread silicone compound as evenly as possible to maintain a depth of 2 mm over chafed area. Taper silicone compound off to surrounding areas.
4. After application of silicone compound, the armature must remain at room temperature for 24 hours to cure the silicone compound before proceeding with subsequent operations. Heating and varnish treatment will destroy the silicone compound if silicone compound is not allowed to cure properly.
5. Prepare the armature for vacuum impregnation. Cover the diamond area with one butted layer of fiberglass tape for protection during varnish treatment.
6. Armature should now be vacuum impregnated with varnish. Refer to Varnish Treatment portion of this section.

Spread silicone compound so there is a continuous layer between adjacent chafed coils. Do not attempt to cover individual coils in areas where adjacent coils are chafed.

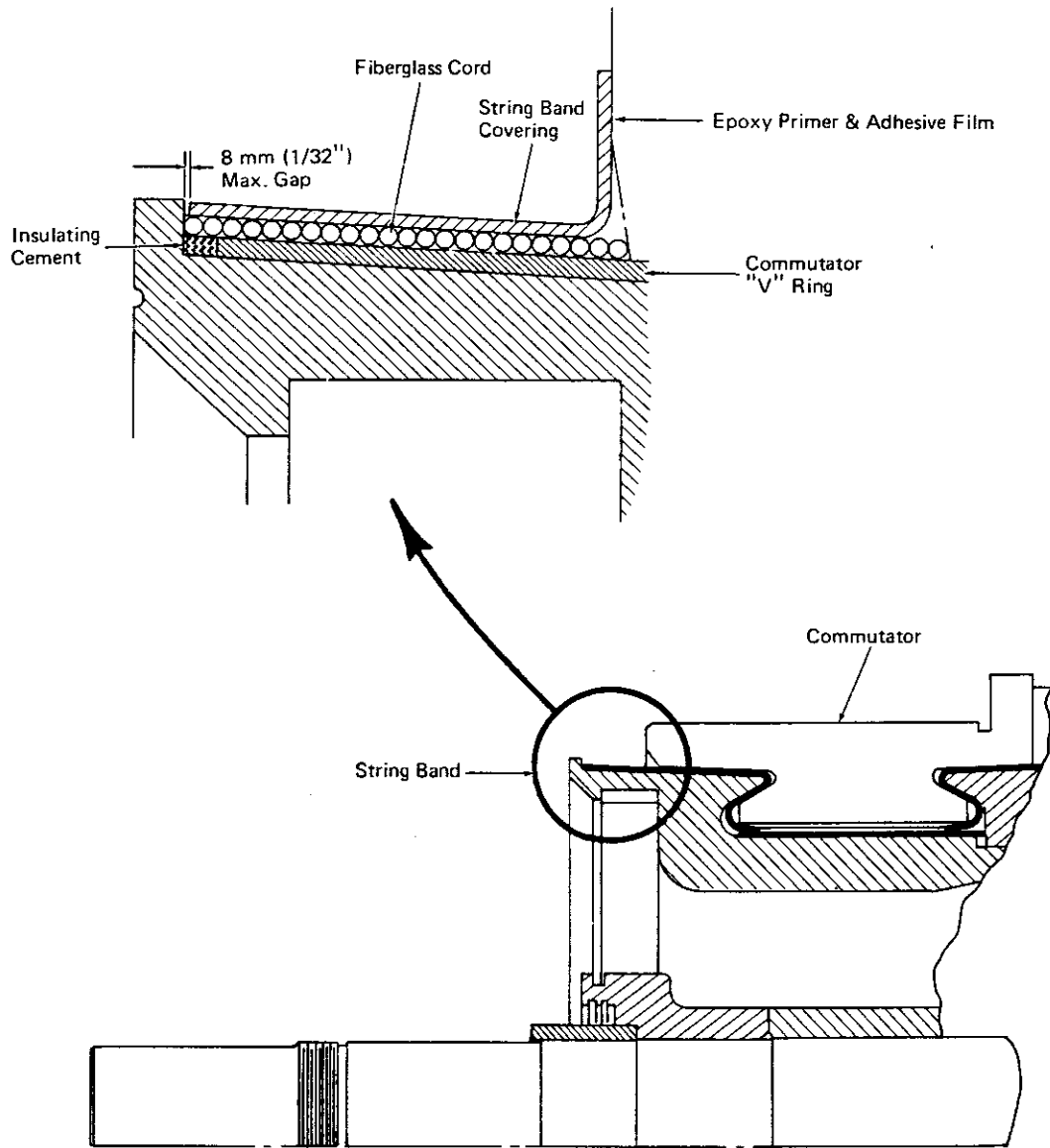

21959

Fig. 8 - Commutator End String Band Application

2. Lightly brush the insulation protruding from under the wire band on both sides.
3. Ensure the area to be coated is free of dirt and paint. Epoxy must have a clean bonding area.
4. Wipe wire band with Xylol.
5. Apply one turn of 25 mm masking tape to top of commutator reser.
6. Mix epoxy resin kit per instructions furnished with kit. Refer to Service Data for kit part number.
7. Apply a coat of epoxy resin with a 51 mm brush from the rear edge of the commutator riser to the edge of the insulation under the band at the core side of the band. Coat the surface of the wire band as evenly as possible.

**NOTE:** The application of epoxy resin should require about  $\frac{1}{2}$  of the mixed resin.

8. Apply one layer of ten mil glass tape, one half lapped to the entire surface as follows.

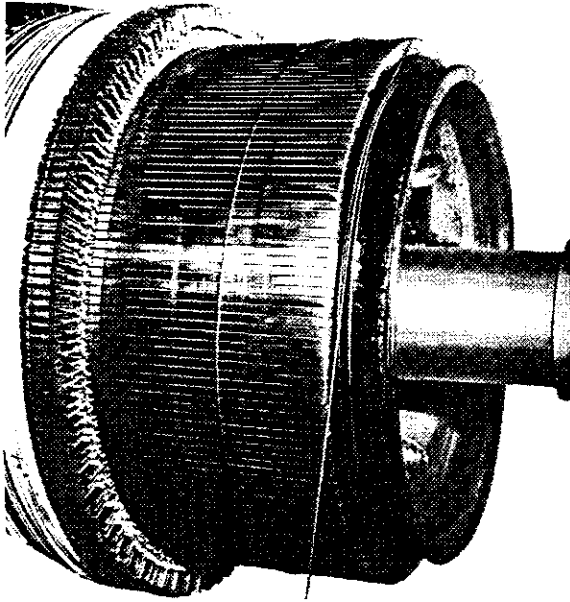

4449

Fig. 9 - Securing Start of String Band

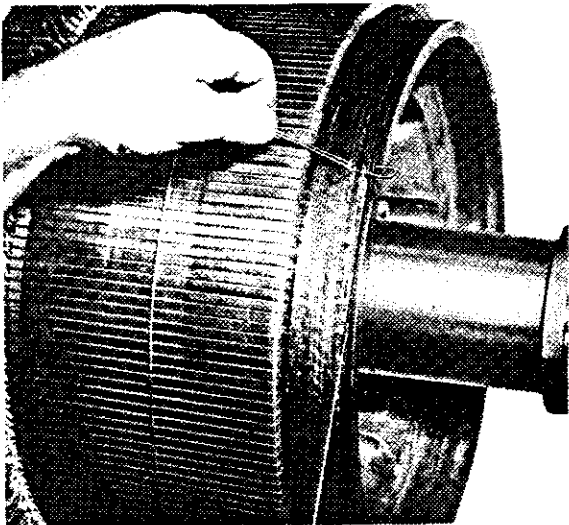

4509

Fig. 10 - Securing Finish of String Band

- a. Begin taping next to the commutator riser. Hold end of tape in place with epoxy resin.
- b. Wrap the half lapped layers across the entire area end so that the last turn is even with the edge of the insulation on the core side of the band.
- c. Apply tape as tightly as possible. Rotate armature as tape is applied.

9. Apply remainder of epoxy resin to the taped surface. Cover surface thoroughly, working resin into tape. To smooth out resin, rotate armature while holding brush against the coated area.

10. The armature must be rotated during time required to cure the epoxy resin. This rotation is required to prevent uneven surfaces from forming. The resin will cure at room temperature in  $2\frac{1}{2}$  to 4 hours; however this time can be accelerated by applying heat to the resin. The heat can be applied with infrared lamps or by placing the armature into an oven for 20 minutes with an oven temperature between  $135^{\circ}\text{C}$  to  $150^{\circ}\text{C}$  ( $275^{\circ}\text{F}$  to  $302^{\circ}\text{F}$ ). Regardless of the curing method used, the armature must be rotated during the curing period.

When it is required to replace the wire or fiberglass tension bands, refer to Section 6 of this Maintenance Instruction.

When armature coils are chafed either lightly or to the extent that the copper coil straps are exposed in the area under the tension band, and the armature otherwise checks satisfactorily, chafed coils may be repaired as follows:

1. Lightly sand over the chafed area with fine sandpaper to remove any dirt or carbon from chafed edges of the insulation and to remove any oxidation or varnish from the exposed strap.